



ALL SHORE INDUSTRIES, INC.

SPECIFICATION FOR LIQUID CRYSTAL DISPLAY MODULE

MODULE #: ASI-_-2406CS-LL-_YS/W

- (1) NUMBER OF DOT----- 240 W* 64 H DOTS
- (2) MODULE SIZE----- 140.0 W * 62.0 H * "C" T (Max) mm
- (3) EFFECTIVE AREA----- 116.0 W * 37.0 H mm
- (4) ACTIVE AREA----- 105.57 W * 31.97 H mm
- (5) DOT SIZE ----- 0.41 W * 0.47 H mm
- (6) DOT PITCH----- 0.44 W * 0.50 H mm



MODEL NO : ASI_-2406CS-LL-_YS/W

RECORDS OF REVISION		DOC . FIRST ISSUE May, 2005
DATE	REVISED DRAWING NO.	SUMMARY



MODEL NO : ASI_-2406CS-LL-_YS/W

LCD MODULE PART NUMBERING SYSTEM

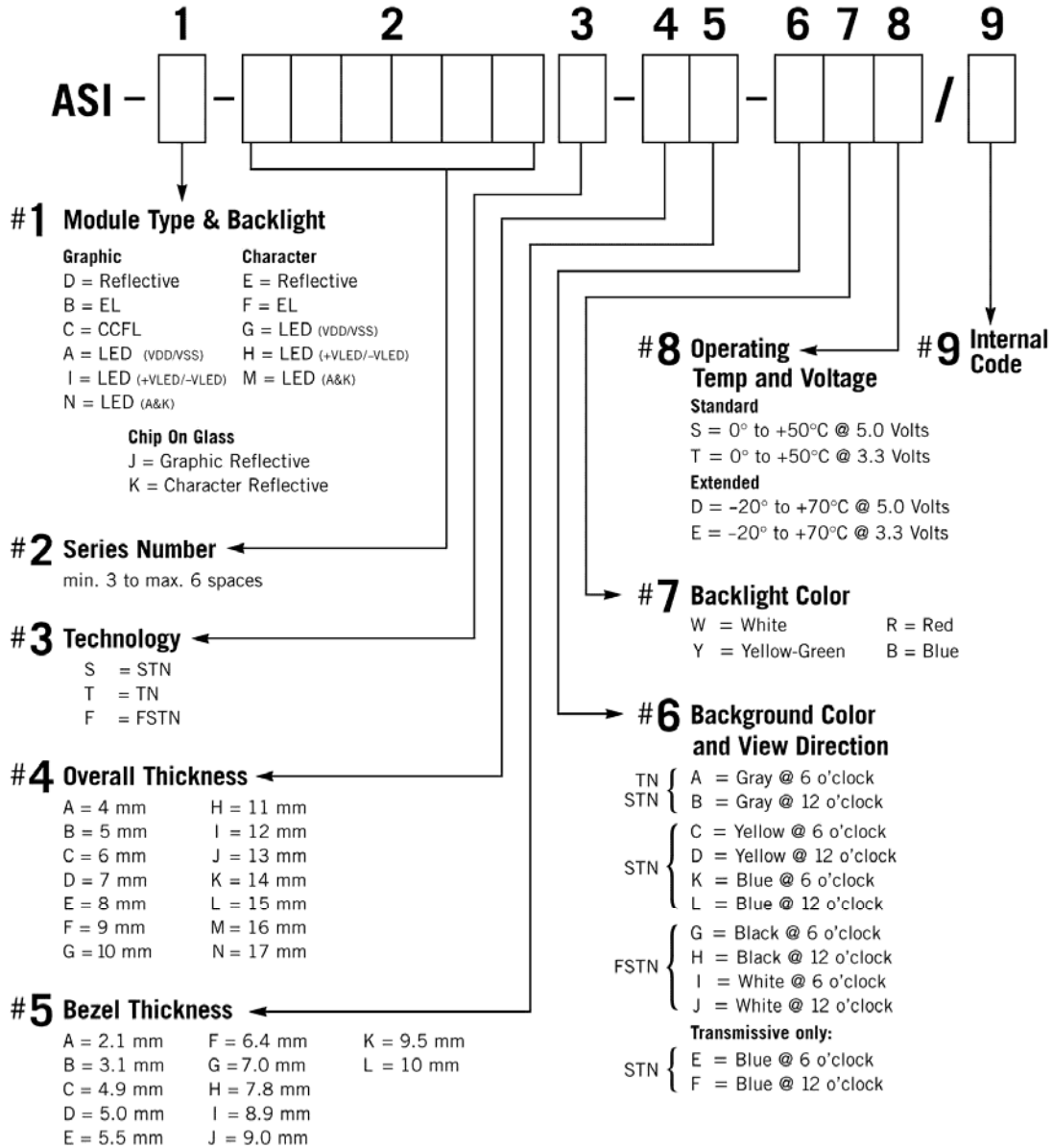

NOTE: Some options may not be available in specific modules. Please contact your Sales Representative to check availability.



MODEL NO : ASI_-2406CS-LL-_YS/W

1. GENERAL SPECIFICATIONS

1.1 GENERAL SPECIFICATIONS

PLEASE REFER TO :

"CUSTOMER ACCEPTANCE STANDARD SPECIFICATIONS :

1.2 APPLICATION NOTES FOR CONTROLLER / DRIVER :

PLEASE REFER TO :

CUSTOMER ACCEPTANCE STANDARD SPECIFICATIONS :

1.3 THIS INDIVIDUAL SPECIFICATIONS IS PRIOR TO GENERAL SPECIFICATIONS .

2. MECHANICAL SPECIFICATIONS

- (1) NUMBER OF DOT----- 240 W* 64 H DOTS
- (2) MODULE SIZE----- 140.0 W * 62.0 H * "C" T (Max) mm
- (3) EFFECTIVE AREA----- 116.0 W * 37.0 H mm
- (4) ACTIVE AREA----- 105.57 W * 31.97 H mm
- (5) DOT SIZE ----- 0.41 W * 0.47 H mm
- (6) DOT PITCH----- 0.44 W * 0.50 H mm



MODEL NO : ASI_-2406CS-LL-_YS/W

3. ABSOLUTE MAXIMUM RATINGS

3.1 ELECTRICAL ABSOLUTE MAXIMUM RATINGS.

Electrical absolute maximum ratings

<i>I T E M</i>	<i>SYMBOL</i>	<i>MIN.</i>	<i>MAX.</i>	<i>UNIT</i>	<i>COMMENT</i>
POWER SUPPLY FOR LOGIC	V _{DD} -V _{SS}	0	6.0	V	-----
INPUT VOLTAGE	V _I	V _{SS}	V _{DD}	V	-----
STATIC ELECTRICITY	-----	-----	100	V	NOTE (1)
POWER SUPPLY FOR EL BACKLIGHT	V _{EL}	-----	AC200	V _{rms}	f _{EL} =1.0KHz 60 SEC.MAX
	f _{EL}	-----	2.0	KHz	AC115 V _{rms} 60 SEC.MAX
POWER SUPPLY FOR LED	V _{LED}	-----	5.0	V	-----

NOTE (1): ELECTRO-STATIC DISCHARGE RESISTANCE IS TESTED BY CHARGING A 200PF CAPACITOR AND DISCHARGING IT BY CONTACT WITH A INTERFACE CONNECTOR PIN.

Environmental absolute maximum ratings

<i>I T E M</i>	<i>OPERATING</i>		<i>STORAGE</i>		<i>COMMENT</i>
	<i>MIN.</i>	<i>MAX.</i>	<i>MIN.</i>	<i>MAX.</i>	
AMBIENT TEMPERATURE	-20°C	70°C	-20°C	70°C	-----
HUMIDITY	NOTE (2)		NOTE (2)		NO CONDENSATION
VIBRATION NOTE (3)	-----	0.5G	-----	2G	10~300HZ XYZ DIRECTIONS 1 Hr EACH
SHOCK NOTE (3)	-----	3G	-----	50G	10 msec XYZ DIRECTIONS 1 TIME EACH
CORROSIVE GAS	NOT ACCEPTABLE		NOT ACCEPTABLE		-----

NOTE (2): T_a ≤ 50°C: 90% RH MAX.

T_a > 50°C: ABSOLUTE HUMIDITY MUST BE LOWER THAN THE HUMIDITY OF 90% RH AT 50°C. (80%RH AT 60°C)

NOTE (3): 1G = 9.8 m/s²



MODEL NO : ASI_-2406CS-LL-_YS/W

3.3 ENVIRONMENTAL ABSOLUTE MAXIMUM RATINGS .

Electrical characteristics

$$T_a = 25^{\circ}\text{C} \quad V_{DD} = 5.060.25 \text{ V}$$

ITEM	SYMBOL	CONDITION	MIN.	TYP.	MAX.	UNIT	
POWER SUPPLY VOLTAGE FOR CIRCUIT	$V_{DD}-V_{SS}$	-----	4.75	5.0	5.25	V	
INPUT VOLTAGE	V_{IH}	H LEVEL	2.0	-----	V_{DD}	V	
	V_{IL}	L LEVEL	0	-----	0.8	V	
OUTPUT VOLTAGE	V_{OH}	$I_{OH} = -0.3 \text{ mA}$	2.4	-----	V_{DD}	V	
	V_{OL}	$I_{OH} = 3.0 \text{ mA}$	0	-----	0.4	V	
POWER SUPPLY CURRENT	I_{DD}	$V_{DD}-V_{SS} = 5.0 \text{ V}$	-----	10.0	20.0	mA	
RECOMMENDED LCD DRIVING VOLTAGE, NOTE(1)	$V_{DD}-V_o$	STN/ FSTN DUTY =1/64 $\Phi=10^{\circ}$ NOTE(2)	$T_a=-20^{\circ}\text{C}$	-----	8.9	-----	V
			$T_a=25^{\circ}\text{C}$	-----	8.5	-----	V
			$T_a=70^{\circ}\text{C}$	-----	8.1	-----	V
POWER SUPPLY CURRENT FOR EL BACKLIGHT	I_{EL}	$V_{EL} = 115V_{rms}$ $f_{EL} = 400\text{Hz}$	-----	8.0	-----	mArms	
POWER SUPPLY CURRENT FOR LED	I_{LED}	NOTE(3)	-----	NOTE(3)	NOTE(3)	mA	

NOTE (1): RECOMMENDED LCD DRIVING VOLTAGE MAY FLUCTUATE ABOUT $\pm 0.5\text{V}$ BY EACH MODULE.

(2): $\theta = 0^{\circ}$: VIEWING DIRECTION AT 6 O'CLOCK

$\theta = 180^{\circ}$: VIEWING DIRECTION AT 12 O'CLOCK

(3): LED CURRENT FOR DIFFERENT LED BACKLIGHT TYPE

LED B.L TYPE	CONDITION	I_{LED}				LED COLOR
		MIN.	TYP.	MAX.	UNIT.	
LED B.L (ARRAY)	$V_{LED} = 5.0\text{V}$	-----	280	420	mA	YELLOW-GREEN RED · AMBER · ORANGE
LED B.L (EDGE)	$V_{LED} = 4.0\text{V}$	-----	75	100	mA	BLUE · WHITE PURE-GREEN



MODEL NO : ASI_-2406CS-LL-_YS/W

4. ELECTRICAL CHARACTERISTICS

<i>I T E M</i>	<i>SYMBOL</i>	<i>CONDITION</i>	<i>MIN.</i>	<i>TYP.</i>	<i>MAX.</i>	<i>UNIT</i>	
POWER SUPPLY VOLTAGE FOR CIRCUIT	V_{DD-VSS}	-----	4.75	5.0	5.25	V	
INPUT VOLTAGE	V_{IH}	H LEVEL	2.0	-----	V_{DD}	V	
	V_{IL}	L LEVEL	0	-----	0.8	V	
OUTPUT VOLTAGE	V_{OH}	$I_{OH} = -0.3 \text{ mA}$	2.4	-----	-----	V	
	V_{OL}	$I_{OH} = 3.0 \text{ mA}$	-----	-----	0.4	V	
POWER SUPPLY CURRENT	I_{DD}	$V_{DD-VSS} = 5.0 \text{ V}$	-----	10.0	20.0	mA	
RECOMMENDED LCD DRIVING VOLTAGE, NOTE(1)	V_{DD-V_O}	STN/ FSTN DUTY =1/64 $\Phi=10^\circ$ NOTE(2)	$T_a = -20^\circ\text{C}$	-----	8.9	-----	V
		$T_a = 25^\circ\text{C}$	-----	8.5	-----	V	
		$T_a = 70^\circ\text{C}$	-----	8.1	-----	V	
POWER SUPPLY CURRENT FOR EL BACKLIGHT	I_{EL}	$V_{EL} = 115V_{rms}$ $f_{EL} = 400\text{Hz}$	-----	8.0	-----	mArms	
POWER SUPPLY CURRENT FOR LED	I_{LED}	NOTE(3)	-----	NOTE(3)	NOTE(3)	mA	

NOTE (1): RECOMMENDED LCD DRIVING VOLTAGE MAY FLUCTUATE ABOUT $\pm 0.5\text{V}$ BY EACH MODULE.

(2): $\theta = 0^\circ$: VIEWING DIRECTION AT 6 O'CLOCK

$\theta = 180^\circ$: VIEWING DIRECTION AT 12 O'CLOCK

(3): LED CURRENT FOR DIFFERENT LED BACKLIGHT TYPE

<i>LED B.L TYPE</i>	<i>CONDITION</i>	<i>I_{LED}</i>				<i>LED COLOR</i>
		<i>MIN.</i>	<i>TYP.</i>	<i>MAX.</i>	<i>UNIT.</i>	
LED B.L (ARRAY)	$V_{DD} = 5.0\text{V}$	-----	280	420	mA	YELLOW-GREEN、RED AMBER、ORANGE
LED B.L (EDGE)	$V_{LED} = 4.0\text{V}$	-----	75	100	mA	BLUE、WHITE PURE-GREEN



MODEL NO : ASI_-2406CS-LL-_YS/W

5. OPTICAL CHARACTERISTICS.

Optical characteristics

STN TYPE LCD

$$T_a = 25^{\circ}\text{C} \quad V_{DD}-V_O = 8.5V$$

ITEM	SYMBOL	CONDITION	MIN.	TYP.	MAX.	UNIT	NOTE
VIEWING ANGLE	$\Phi 2-\Phi 1$	K = 2.0 NOTE(1)	30	40	----	deg.	NOTE(2)
CONTRAST RATIO	K	$\Phi = 10^{\circ}$ NOTE(1)	3.0	4.0	----	----	NOTE(2)
RESPONSE TIME	tr (rise)	$\Phi = 10^{\circ}$ NOTE(1)	----	200	350	ms	NOTE(2)
	tf (fall)	$\Phi = 10^{\circ}$ NOTE(1)	----	300	400	ms	NOTE(2)

FSTN、STN BLUE TYPE LCD

$$T_a = 25^{\circ}\text{C} \quad V_{DD}-V_O = 8.5V$$

ITEM	SYMBOL	CONDITION	MIN.	TYP.	MAX.	UNIT	NOTE
VIEWING ANGLE	$\Phi 2-\Phi 1$	K = 2.0 NOTE(1)	30	40	----	deg.	NOTE(2)
CONTRAST RATIO	K	$\Phi = 10^{\circ}$ NOTE(1)	4.0	5.0	----	----	NOTE(2)
RESPONSE TIME	tr (rise)	$\Phi = 10^{\circ}$ NOTE(1)	----	200	350	ms	NOTE(2)
	tf (fall)	$\Phi = 10^{\circ}$ NOTE(1)	----	300	400	ms	NOTE(2)

Brightness for LCM backlight

SYMBOL	CONDITION	MIN.	TYP.	MAX.	UNIT	LED TYPE	NOTE
B	$\Phi = 0^{\circ}$ $\theta = 0^{\circ}$	4.0	----	----	cd/m ²	EL BACKLIGHT	NOTE(2) NOTE(3)
		5.0	----	----		YELLOW-GREEN、RED AMBER、ORANGE	
		6.0	----	----		BLUE、WHITE、 PURE-GREEN	

NOTE (1): $\theta = 0^{\circ}$: VIEWING DIRECTION AT 6 O'CLOCK

$\theta = 180^{\circ}$: VIEWING DIRECTION AT 12 O'CLOCK

NOTE (2): SEE CUSTOMER ACCEPTANCE STANDARD SPECIFICATION FOR DEFINITION OF OPTICAL CHARACTERISTICS.

NOTE (3): UNDER NORMAL TEMPERATURE AND HUMIDITY IN A DARK ROOM.

MODEL NO : ASI_-2406CS-LL-_YS/W

Outline dimension

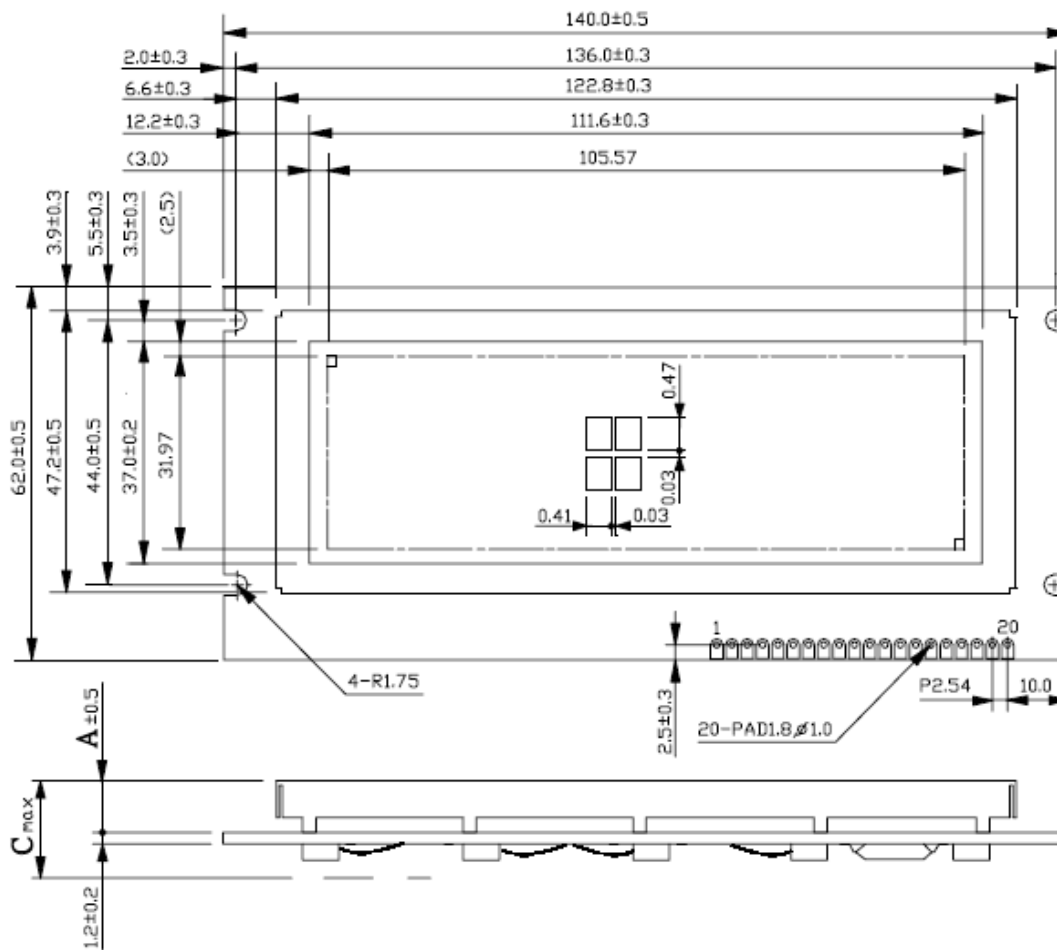

TYPE	A	C
LED B.L	10.0	15.0
EL & NO B.L	4.9	9.5

NOTE :
 1.UNIT : mm
 2.SCALE : NTS



MODEL NO : ASI_-2406CS-LL-_YS/W

Interface pin connection

PIN NO.	SYMBOL	FUNCTION
1	V _{SS}	POWER SUPPLY (GND)
2	V _{DD}	POWER SUPPLY (+5.0V)
3	V _O	OPERATING VOLTAGE FOR LCD DRIVING
4	RS	L : DATA INPUT H : INSTRUCTION CODE INPUT
5	R \overline{W}	H: DATA READ (LCD MODULE → MPU) L: DATA WRITE (LCD MODULE ← MPU)
6	E	ENABLE SINGAL
7	DB0	DATA INPUT/OUTPUT (LSB)
8	DB1	DATA INPUT/OUTPUT
9	DB2	DATA INPUT/OUTPUT
10	DB3	DATA INPUT/OUTPUT
11	DB4	DATA INPUT/OUTPUT
12	DB5	DATA INPUT/OUTPUT
13	DB6	DATA INPUT/OUTPUT
14	DB7	DATA INPUT/OUTPUT (MSB)
15	\overline{CS}	L: CHIP ENABLE
16	\overline{RES}	L: RESET
17	V _{EE}	POWER SUPPLY FOR LCD DRIVING OUTPUT
18	N.C	NO CONNECTION
19	A(+) (V _{EL})	POWER SUPPLY FOR LED BACKLIGHT (+) (POWER SUPPLY FOR EL)
20	K(-) (V _{EL})	POWER SUPPLY FOR LED BACKLIGHT (-) (POWER SUPPLY FOR EL)



MODEL NO : ASI_-2406CS-LL-_YS/W

Block diagram

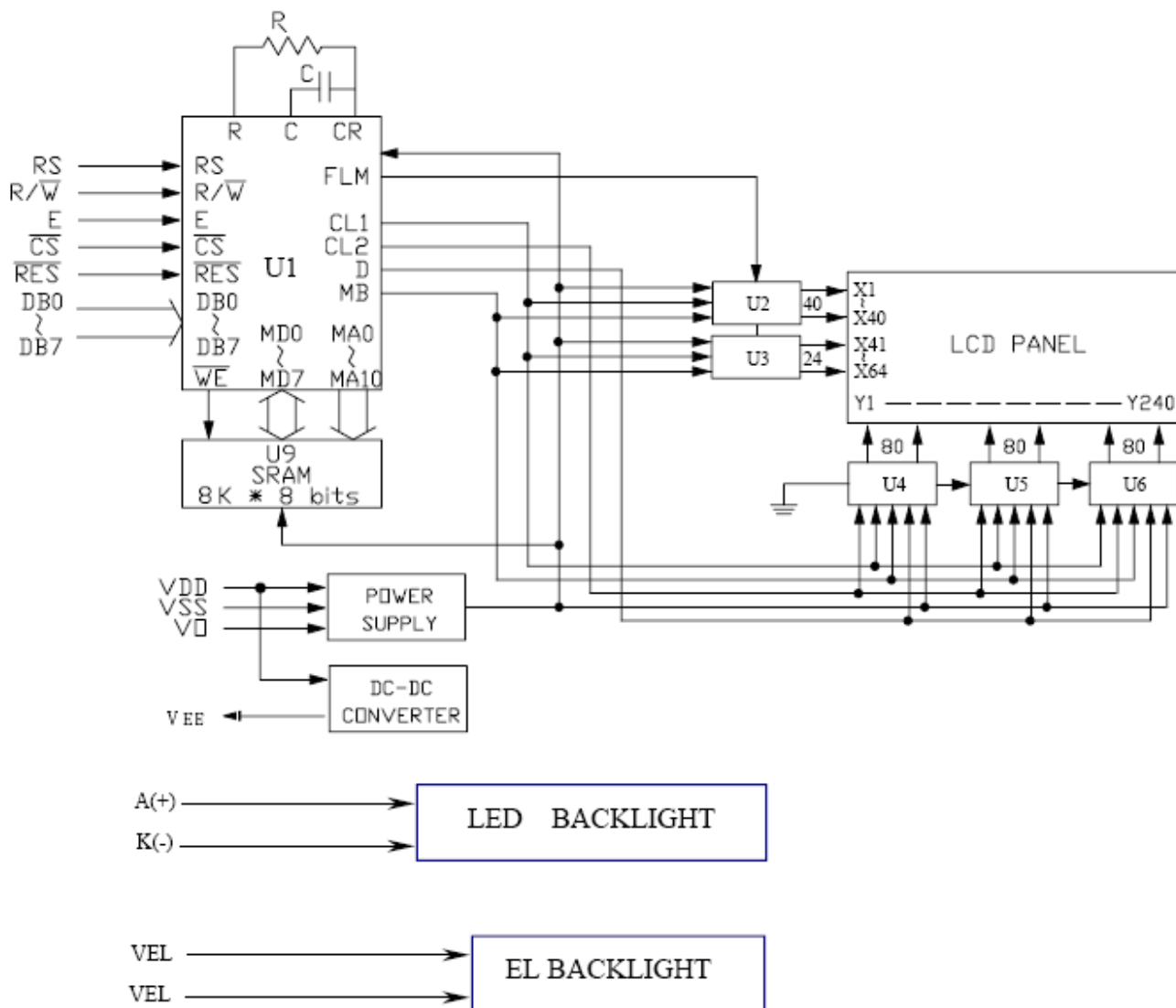



MODEL NO : ASI_-2406CS-LL-_YS/W

Power supply for LCM

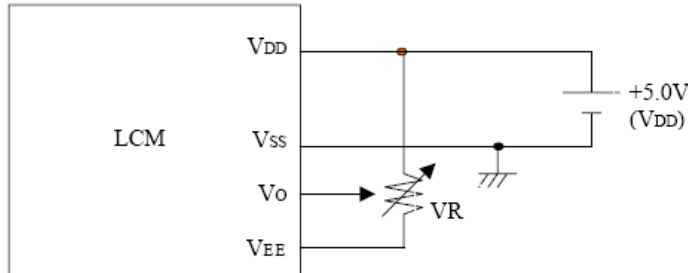

V_{DD}-V_o: LCD DRIVING VOLTAGE
 VR: 200KΩ

10.1 Power supply for backlight

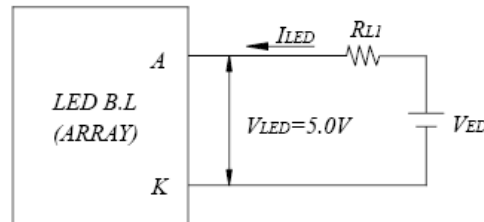
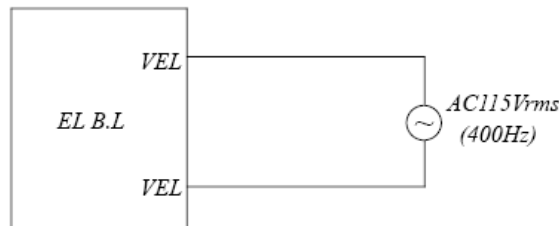

$$RL1 \geq (V_{ED} - V_{LED}) / I_{LED}, I_{LED} \leq 420.0 \text{ mA (max)}$$

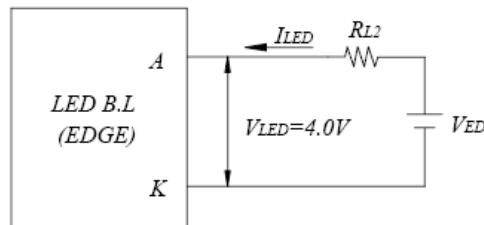

$$RL2 \geq (V_{ED} - V_{LED}) / I_{LED}, I_{LED} \leq 100.0 \text{ mA (max)}$$

The information presented in this datasheet has been carefully checked and is believed to be accurate; however, no responsibility is assumed for inaccuracies. Information contained herein is for selection purposes only, and is subject to change without notice. Please contact ASI for current datasheets prior to designing.