



ASI-T-570EA8 TN/D

Item	Contents	Unit
Size	5.7	inch
Resolution	320x(RGB) x 240	/
Technology type	a-Si TFT	/
Interface	TTL	
Pixel pitch(W x H)	0.36x0.36	mm
Pixel Configuration	R.G.B. Vertical Stripe	
Outline Dimension (W x H x D)	127.0 x 98.43x9.2	mm
Active Area(W x H)	115.2 x 86.4	mm
Display Mode	Transmissive, Normally White	/
Backlight Type	LED	/



Record of Revision

Date	Revision No.	Summary
2012-08-13	1.0	Rev 1.0 was issued

1. Scope

This data sheet is to introduce the specification of ASI-T-570EA8 TN/D, active matrix TFT module. It is composed of a color TFT-LCD panel, driver ICs, FPC and a backlight unit. The 5.7 " display area contains 320(RGB) x 240 pixels.

2. Application

Digital equipments which need color display, medical or industrial application.

3. General Information

Item	Contents	Unit
Size	5.7	inch
Resolution	320x(RGB) x 240	/
Technology type	a-Si TFT	/
Interface	TTL	
Pixel pitch(W x H)	0.36x0.36	mm
Pixel Configuration	R.G.B. Vertical Stripe	
Outline Dimension (W x H x D)	127.0 x 98.43x9.2	mm
Active Area(W x H)	115.2 x 86.4	mm
Display Mode	Transmissive, Normally White	/
Backlight Type	LED	/

4. Outline Drawing

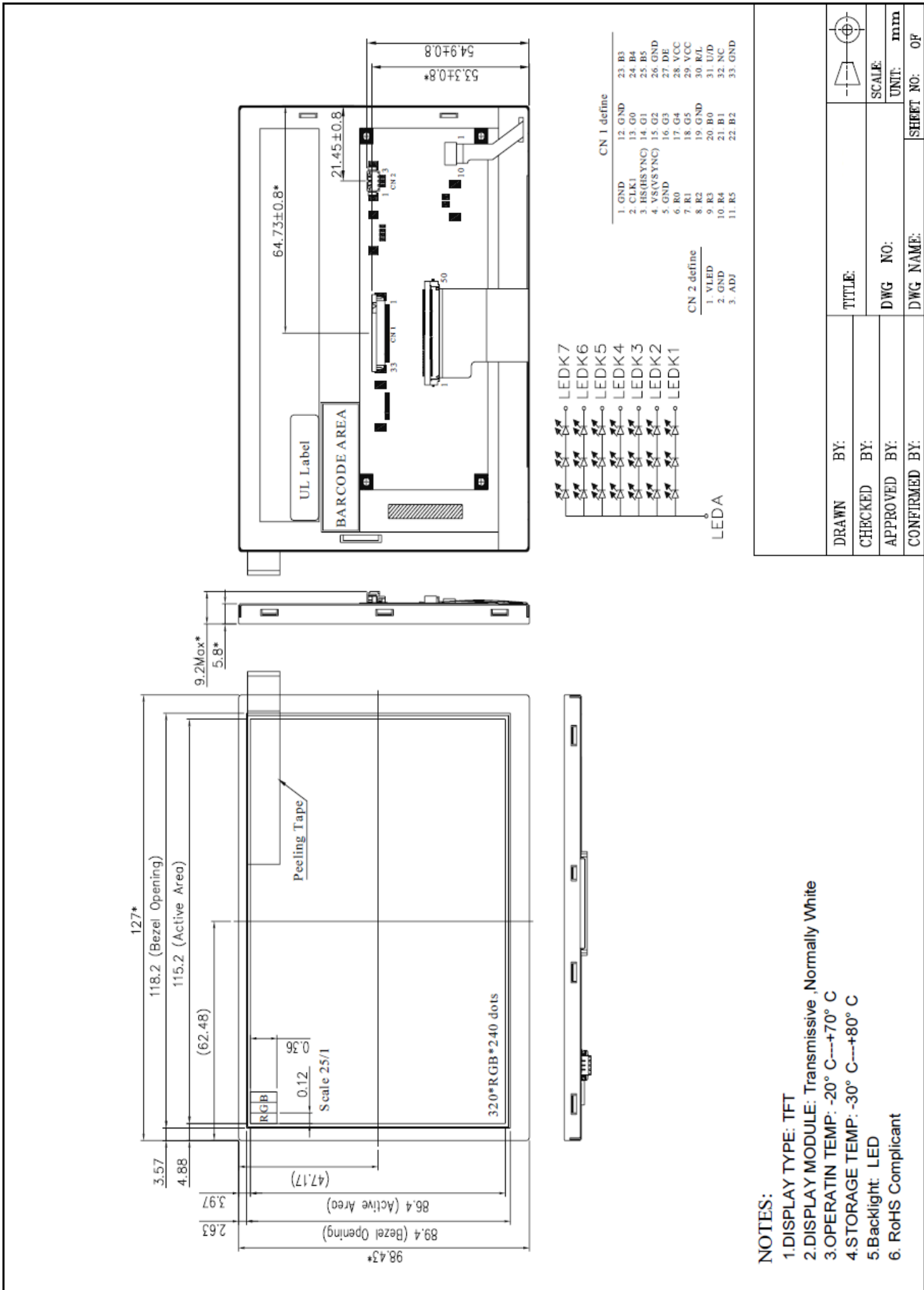

5. Interface signals

5.1 TFT PIN:

No	Symbol	Description	Remarks
1	GND	Ground for logic circuit	
2	CLK1	Data sampling clock	
3	HSYNC	Horizontal synchronous signal	
4	VSYNC	Vertical synchronous signal	
5	GND	Ground	
6	R0	Red pixel data(LSB)	
7	R1	Red pixel data	
8	R2	Red pixel data	
9	R3	Red pixel data	
10	R4	Red pixel data	
11	R5	Red pixel data(MSB)	
12	GND	Ground	
13	G0	Green pixel data(LSB)	
14	G1	Green pixel data	
15	G2	Green pixel data	
16	G3	Green pixel data	
17	G4	Green pixel data	
18	G5	Green pixel data(MSB)	
19	GND	Ground	
20	B0	Blue pixel data(LSB)	
21	B1	Blue pixel data	
22	B2	Blue pixel data	
23	B3	Blue pixel data	
24	B4	Blue pixel data	
25	B5	Blue pixel data(MSB)	
26	GND	Ground	
27	DE	Data enable(connected to GND, if sync mode)	
28	VCC	Power supply:+3.3v	

29	VCC	Power supply:+3.3v	
30	R/L	Horizontal display mode select signal. Left /right scan control input	
31	U/D	Vertical display mode select signal. Up/down scan control input	
32	NC	No connection	
33	GND	Ground	

Note1 The horizontal display start timing is settled in accordance with a rising timing of DE signal. In case DE is fixed "Low", the horizontal start timing is determined as described in 9.2. Don't keep DE "High" during operation.

Note2: U/D and L/R control Function

L/R	U/D	Function
0	1	Normally display
1	1	Left and Right opposite
0	0	Up and Down opposite
1	0	Left and Right opposite, Up and Down opposite

5.2 CN2 PINs Connections:

No	Symbol	Description	Remarks
1	VLED	Power supply for LED driver circuit	
2	GND	ground	
3	ADJ	brightness control for LED B/L	

*ADJ is brightness control pin. The larger of the pulse duty is, higher of the brightness.

6. Absolute maximum Ratings

6.1. Electrical Absolute max. ratings

Parameter	Symbol	MIN	MAX	Unit	Remark
Power supply Voltage	VCC	-0.3	5.0	V	
Logic input voltage	VIN	-0.3	VCC+0.3	V	

6.2 Environment Conditions

Item	Symbol	MIN	MAX	Unit	Remark
Operating Temperature	TOPR	-20	70	°C	
Storage Temperature	TSTG	-30	80	°C	

7. Electrical Specifications

7.1 Electrical characteristics

GND=0V, Ta=25°C

Item	Symbol	MIN	TYP	MAX	Unit	Remark
Power Supply Voltage	VCC	3.0	3.3	3.6	V	
Power Supply Current	Icc	-	62	80	mA	VCC=3.3V
Ripple voltage	V _{RF}	-	-	100	mVp-p	
Input Signal Voltage	V _{IL}	0	-	0.3*VCC	V	
	V _{IH}	0.7*VCC	-	VCC	V	
ADJ frequency		19K	20K	21K	Hz	
ADJ input voltage	V _{IL}	0	-	0.3		
	V _{IH}	3.0	-	3.3		

7.2 LED Backlight

Ta=25°C

Item	Symbol	MIN	TYP	MAX	Unit	Remark
Forward Current	I _f	-	333	400	mA	V _{LED} =5.0V
Forward Voltage	V _F	4.5	5.0	5.5	V	
Life time		-	50,000		Hrs	Note 1

Note 1: The "LED life time" is defined as the brightness decrease to 50% original brightness that the ambient temperature is 22°C and LED dice current=20mA.

7.3 Schematic of LCD module system

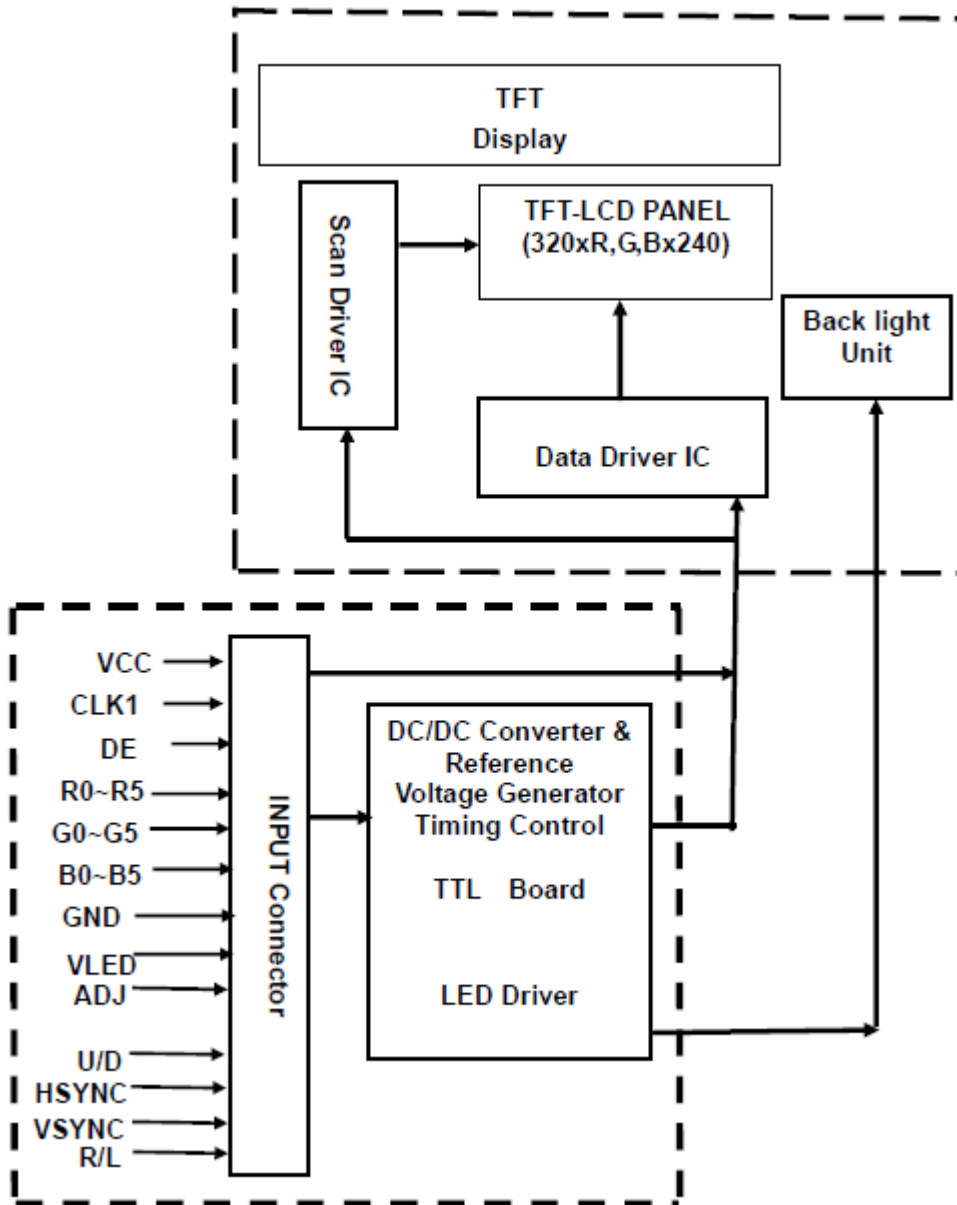

8. Command/AC Timing

8.1 Input Signal Timing Specifications

Parameter		Symbol	MIN.	TYP.	MAX.	Unit	Remarks
CLK	Frequency	1/Tc		7.21		MHz	
	Duty ratio	Th/Tc	40	50	60	%	
DATA	Setup time	Tds	12			ns	
	Hold time	Tdh	12			ns	
Horizontal synchronizing	Period	TH	--	453	--	Clock	
	Pulse width	THp	--	31	--	Clock	
	Horizontal period	THd	--	320	--	Clock	
	Back porch	THb	--	69	--	Clock	
	Front porch	THf	--	33	--	Clock	
Vertical synchronizing	Period	TV	--	267	--	Line	
	Pulse width	TVp	--	6	--	Line	
	Vertical period	TVd	--	240	--	Line	
	Back porch	TVb	--	18	--	Line	
	Front porch	TVf	--	3	--	Line	

Note : In case of using the slow frequency, the deterioration of display flicker etc may occur.
The timing characteristics are basically fixed as above.

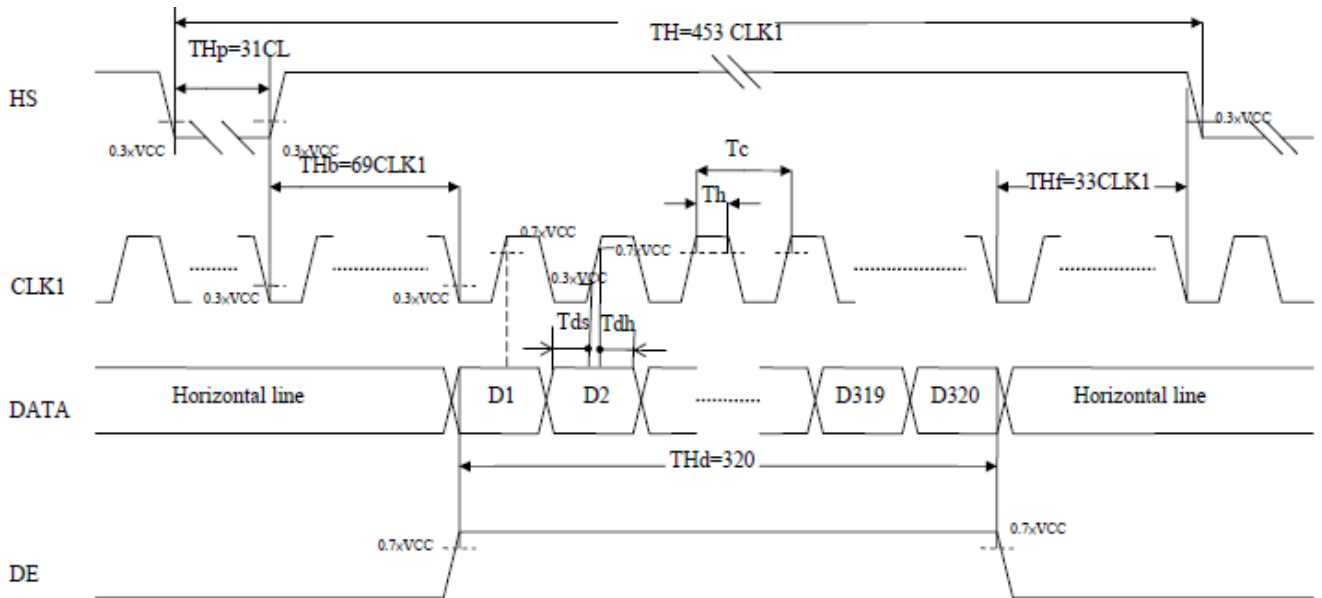

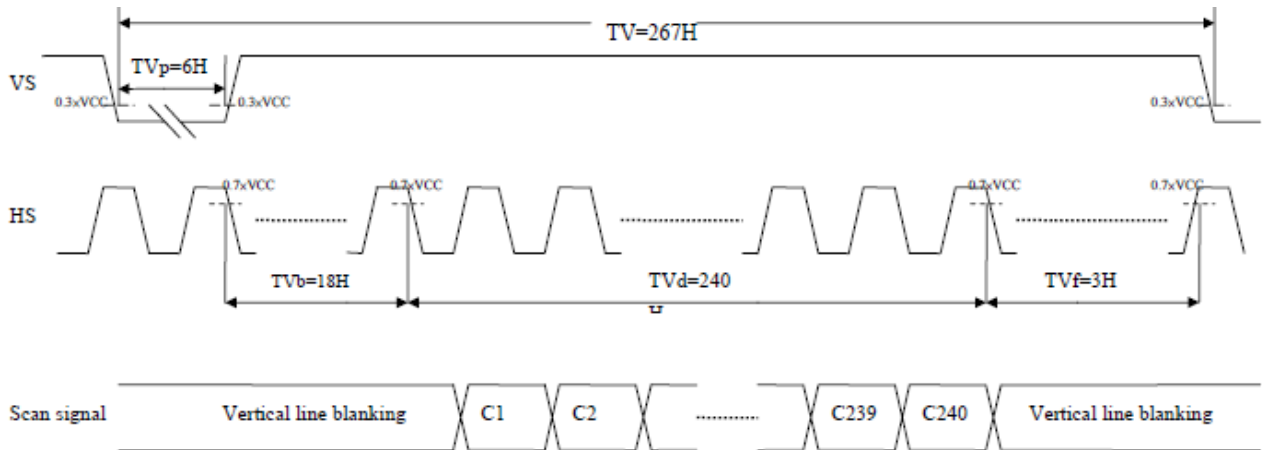

8.2 SYNC mode timing (DE connect to GND)

Parameter		Symbol	MIN.	TYP.	MAX.	Unit	Remarks
CLK	Frequency	$1/T_c$		6.41		MHz	
	Duty ratio	T_h/T_c	40	50	60	%	
DATA	Setup time	T_{ds}	12			ns	
	Hold time	T_{dh}	12			ns	
Horizontal synchronizing	Period	T_H	--	408	--	Clock	
	Pulse width	T_{Hp}	--	30	--	Clock	
	Horizontal period	T_{Hd}	--	320	--	Clock	
	Back porch	T_{Hb}	--	38	--	Clock	
	Front porch	T_{Hf}	--	20	--	Clock	
Vertical synchronizing	Period	T_V	--	262	--	Line	
	Pulse width	T_{Vp}	--	4	--	Line	
	Vertical period	T_{Vd}	--	240	--	Line	
	Back porch	T_{Vb}	--	15	--	Line	
	Front porch	T_{Vf}	--	3	--	Line	

Note:

In case of using the slow frequency, the deterioration of display flicker etc may occur. The timing characteristics are basically fixed as above.



8.3 Color Data Assignment

Color		Data Signal																	
		Red						Green						Blue					
		R5	R4	R3	R2	R1	R0	G5	G4	G3	G2	G1	G0	B5	B4	B3	B2	B1	B0
Basic Colors	Black	0	0	0	0	0	0	0	0	0	0	0	0	0	0	0	0	0	0
	Red	1	1	1	1	1	1	0	0	0	0	0	0	0	0	0	0	0	0
	Green	0	0	0	0	0	0	1	1	1	1	1	1	0	0	0	0	0	0
	Blue	0	0	0	0	0	0	0	0	0	0	0	0	1	1	1	1	1	1
	Cyan	0	0	0	0	0	0	1	1	1	1	1	1	1	1	1	1	1	1
	Magenta	1	1	1	1	1	1	0	0	0	0	0	0	1	1	1	1	1	1
	Yellow	1	1	1	1	1	1	1	1	1	1	1	1	0	0	0	0	0	0
	White	1	1	1	1	1	1	1	1	1	1	1	1	1	1	1	1	1	1
Gray Scale of Red	Red(0) / Dark	0	0	0	0	0	0	0	0	0	0	0	0	0	0	0	0	0	0
	Red(1)	0	0	0	0	0	1	0	0	0	0	0	0	0	0	0	0	0	0
	Red(2)	0	0	0	0	1	0	0	0	0	0	0	0	0	0	0	0	0	0
	:	:	:	:	:	:	:	:	:	:	:	:	:	:	:	:	:	:	:
	:	:	:	:	:	:	:	:	:	:	:	:	:	:	:	:	:	:	:
	Red(61)	1	1	1	1	0	1	0	0	0	0	0	0	0	0	0	0	0	0
	Red(62)	1	1	1	1	1	0	0	0	0	0	0	0	0	0	0	0	0	0
	Red(63)	1	1	1	1	1	1	0	0	0	0	0	0	0	0	0	0	0	0
Gray Scale of Green	Green(0) / Dark	0	0	0	0	0	0	0	0	0	0	0	0	0	0	0	0	0	0
	Green(1)	0	0	0	0	0	0	0	0	0	0	0	1	0	0	0	0	0	0
	Green(2)	0	0	0	0	0	0	0	0	0	0	1	0	0	0	0	0	0	0
	:	:	:	:	:	:	:	:	:	:	:	:	:	:	:	:	:	:	:
	:	:	:	:	:	:	:	:	:	:	:	:	:	:	:	:	:	:	:
	Green(61)	0	0	0	0	0	0	1	1	1	1	0	1	0	0	0	0	0	0
	Green(62)	0	0	0	0	0	0	1	1	1	1	1	0	0	0	0	0	0	0
	Green(63)	0	0	0	0	0	0	1	1	1	1	1	1	0	0	0	0	0	0
Gray Scale of Blue	Blue(0) / Dark	0	0	0	0	0	0	0	0	0	0	0	0	0	0	0	0	0	0
	Blue (1)	0	0	0	0	0	0	0	0	0	0	0	0	0	0	0	0	0	1
	Blue (2)	0	0	0	0	0	0	0	0	0	0	0	0	0	0	0	0	1	0
	:	:	:	:	:	:	:	:	:	:	:	:	:	:	:	:	:	:	:
	:	:	:	:	:	:	:	:	:	:	:	:	:	:	:	:	:	:	:
	Blue (61)	0	0	0	0	0	0	0	0	0	0	0	0	1	1	1	1	0	1
	Blue (62)	0	0	0	0	0	0	0	0	0	0	0	0	1	1	1	1	1	0
	Blue (63)	0	0	0	0	0	0	0	0	0	0	0	0	1	1	1	1	1	1

Correspondence between Data and Display Position

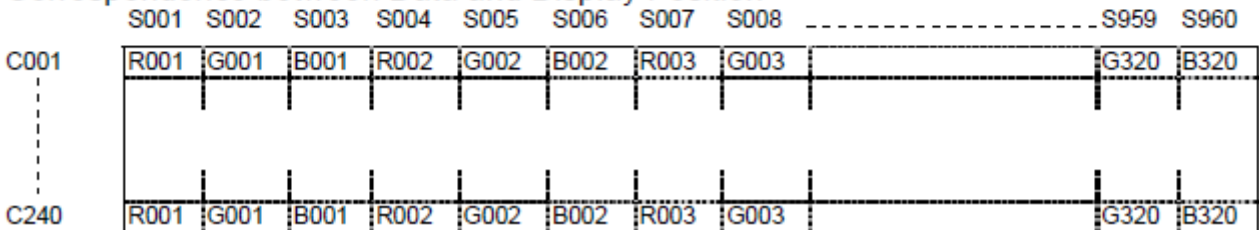

8.4 POWER ON/OFF SEQUENCE

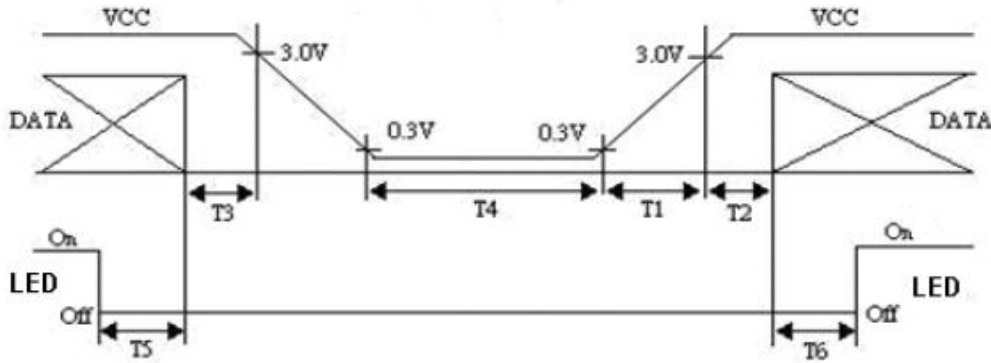

Timing Specifications:
 $0 < T_1 \leq 15\text{mS}$
 $T_2 > 0.5\text{S}$
 $0 < T_3 \leq 0.1\text{S}$
 $T_4 > 1\text{S}$
 $T_5 > 0.1\text{S}$
 $T_6 > 0.1\text{S}$

9. Optical Specification

Item	Symbol	Condition	Min	Typ.	Max.	Unit	Remark
Contrast Ratio	CR	$\theta=0^\circ$	300	350	-		Note1 Note2
Response Time	Ton	25°C	-	15	30	ms	Note1
	Toff			35	30		Note3
View Angles	θT	$CR \geq 10$	40	50	-	Degree	Note 4
	θB		60	70	-		
	θL		60	70	-		
	θR		60	70	-		
Chromaticity	White	x	Brightness is on	Typ-0.05	0.312	Typ+0.05	Note5, Note1
		y			0.320		
	Red	x			0.618		
		y			0.369		
	Green	x			0.351		
		y			0.571		
	Blue	x			0.144		
		y			0.081		
Luminance	L		640	800	-	cd/m ²	Note1 Note6
Uniformity	U		70	80	-	%	Note1 Note7

Note 1: Definition of optical measurement system.

Temperature = 25°C (±3°C)

LED back-light: ON, Environment brightness < 150 lx

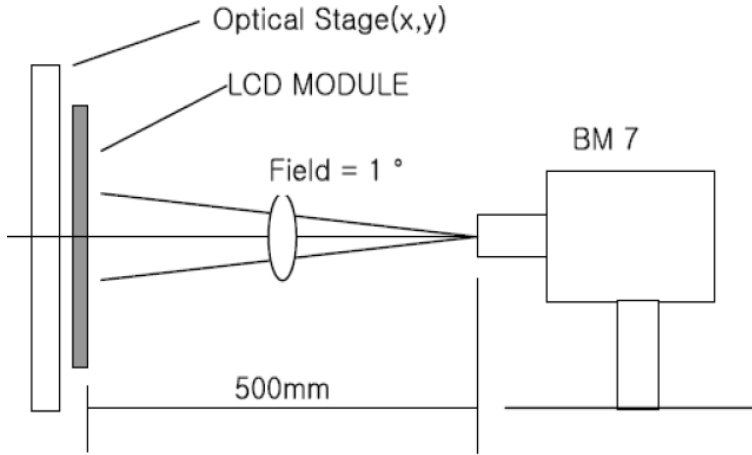

Note 2: Contrast ratio is defined as follow:

$$\text{Contrast Ratio} = \frac{\text{Surface Luminance with all white pixels}}{\text{Surface Luminance with all black pixels}}$$

Note 3: Response time is defined as follow:

Response time is the time required for the display to transition from black to white (Rise Time, Tr) and from white to black (Decay Time, Tf).

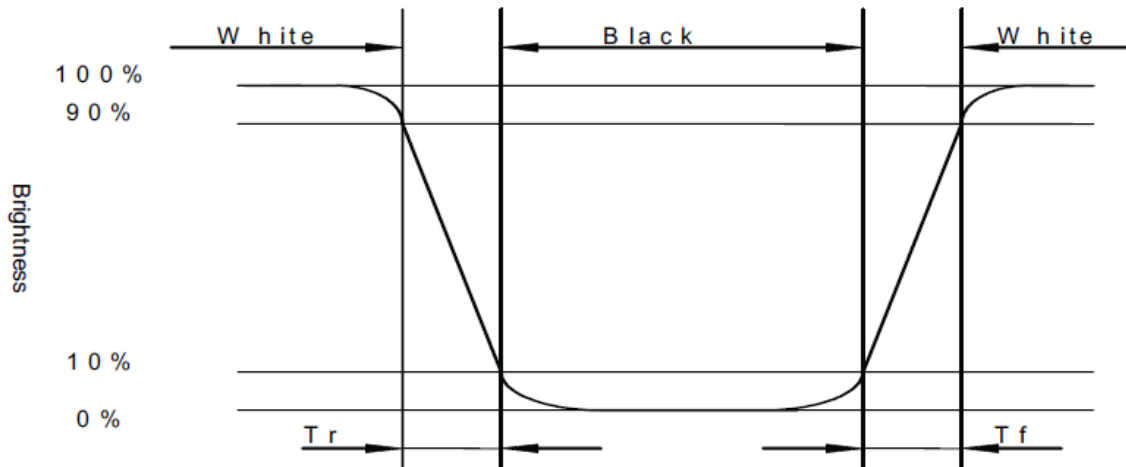

Note 4: Viewing angle range is defined as follow:

Viewing angle is measured at the center point of the LCD.

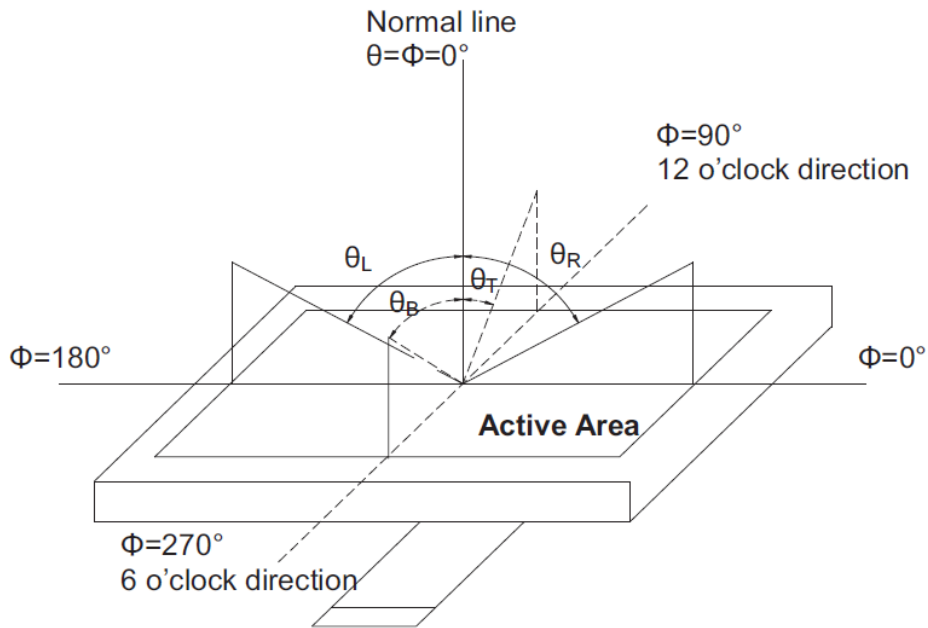

Note 5: Color chromaticity is defined as follow: (CIE1931)

Color coordinates measured at center point of LCD.

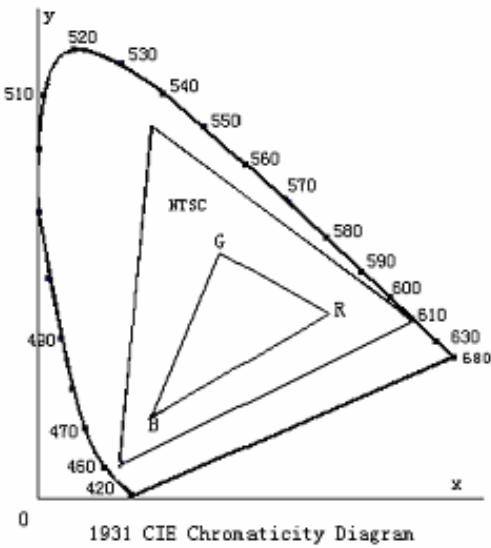

$$S = \frac{\text{area of RGB triangle}}{\text{area of NTSC triangle}} \times 100\%$$

Note 6: Luminance is defined as follow:

Luminance is defined as the brightness of all pixels “White” at the center of display area on optimum contrast

Note 7: Definition of Luminance Uniformity

Active area is divided into 9 measuring areas (Refer Fig. 2). Every measuring point is placed at the center of each measuring area.

Luminance Uniformity (U) = L_{min} / L_{max}

L-----Active area length W----- Active area width

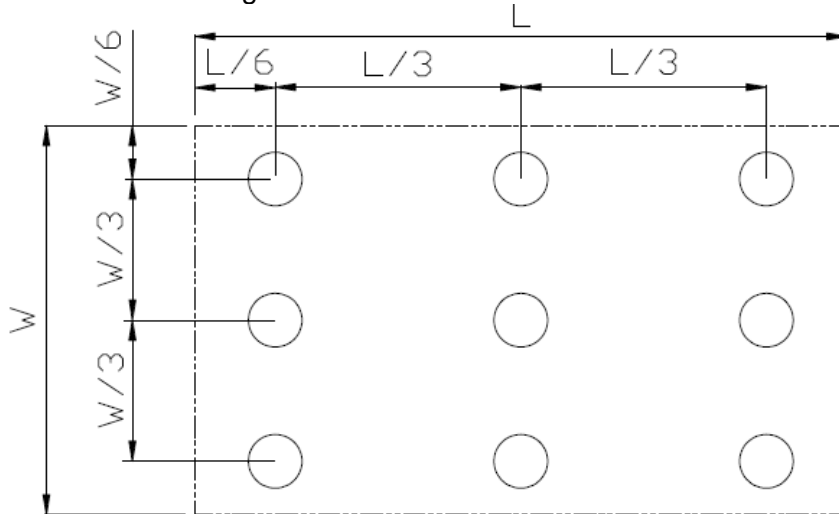

10. Environmental / Reliability Tests

No	Test Item	Condition	Judgment criteria
1	High Temp Operation	Ts=+70°C, 120hrs	Per table in below
2	Low Temp Operation	Ta=-20°C, 120hrs	Per table in below
3	High Temp Storage	Ta=+80°C, 120hrs	Per table in below
4	Low Temp Storage	Ta=-30°C, 120hrs	Per table in below
5	High Temp & High Humidity Storage	Ta=+40°C, 90% RH 120 hours	Per table in below (polarizer discoloration is excluded)
6	Thermal Shock (Non-operation)	-30°C 30 min~+80°C 30 min, Change time:5min, 10 Cycles	Per table in below
7	ESD (Operation)	C=150pF, R=330Ω · 5points/panel Air:±8KV, 5times; Contact:±4KV, 5 times;	Per table in below
8	Vibration (Non-operation)	Frequency range:10~55Hz, Stroke:1.5mm Sweep:10Hz~55Hz~10Hz 2 hours for each direction of X.Y.Z.	Per table in below
9	Shock (Non-operation)	60G 6ms, ±X,±Y,±Z 3times, for each direction	Per table in below
10	Package Drop Test	Height:80 cm, 1 corner, 3 edges, 6 surfaces	Per table in below

INSPECTION	CRITERION(after test)
Appearance	No Crack on the FPC, on the LCD Panel
Alignment of LCD Panel	No Bubbles in the LCD Panel No other Defects of Alignment in Active area
Electrical current	Within device specifications
Function / Display	No Broken Circuit, No Short Circuit or No Black line No Other Defects of Display

11. Precautions for Use of LCD Modules

11.1 Safety

The liquid crystal in the LCD is poisonous. Do not put it in your mouth. If the liquid crystal touches your skin or clothes, wash it off immediately using soap and water.

11.2 Handling

- A. The LCD and touch panel is made of plate glass. Do not subject the panel to mechanical shock or to excessive force on its surface.
- B. Do not handle the product by holding the flexible pattern portion in order to assure the reliability
- C. Transparency is an important factor for the touch panel. Please wear clear finger sacks, gloves and mask to protect the touch panel from finger print or stain and also hold the portion outside the view area when handling the touch panel.
- D. Provide a space so that the panel does not come into contact with other components.
- E. To protect the product from external force, put a covering lens (acrylic board or similar board) and keep an appropriate gap between them.
- F. Transparent electrodes may be disconnected if the panel is used under environmental conditions where dew condensation occurs.
- G. Property of semiconductor devices may be affected when they are exposed to light, possibly resulting in IC malfunctions.
- H. To prevent such IC malfunctions, your design and mounting layout shall be done in the way that the IC is not exposed to light in actual use.

11.3 Static Electricity

- A. Ground soldering iron tips, tools and testers when they are in operation.
- B. Ground your body when handling the products.
- C. Power on the LCD module before applying the voltage to the input terminals.
- D. Do not apply voltage which exceeds the absolute maximum rating.
- E. Store the products in an anti-electrostatic bag or container.

11.4 Storage

- A. Store the products in a dark place at $+25^{\circ}\text{C} \pm 10^{\circ}\text{C}$ with low humidity (40% RH to 60% RH). Don't expose to sunlight or fluorescent light.
- B. Storage in a clean environment, free from dust, active gas, and solvent.

11.5 Cleaning

- A. Do not wipe the touch panel with dry cloth, as it may cause scratch.
- B. Wipe off the stain on the product by using soft cloth moistened with ethanol. Do not allow ethanol to get in between the upper film and the bottom glass. It may cause peeling issue or defective operation. Do not use any organic solvent or detergent other than ethanol.

11.6 Cautions for installing and assembling

Bezel edge must be positioned in the area between the Active area and View area. The bezel may press the touch screen and cause activation if the edge touches the active area. A gap of approximately 0.5mm is needed between the bezel and the top electrode. It may cause unexpected activation if the gap is too narrow. There is a tolerance of 0.2 to 0.3mm for the outside dimensions of the touch panel and tail. A gap must be made to absorb the tolerance in the case and connector.

