



ASI-T-350EB6FN/D

Item	Contents	Unit
Size	3.5	inch
Resolution	320(RGB) x 240	/
Interface	24 bits RGB	/
Technology type	a-Si TFT	/
Pixel pitch	0.219x0.219	mm
Pixel Configuration	R.G.B. Vertical Stripe	
Outline Dimension (W x H x D)	76.8x63.8x3.1	mm
Active Area	70.08 x 52.56	mm
Display Mode	Transmissive, Normally White	/
Backlight Type	LED	/
Driver IC	HX8238D	/



Record of Revision

Date	Revision No.	Summary
2011-04-13	1.0	Rev 1.0 was issued



ASI-T-350EB6FN/D

1. Scope

This data sheet is to introduce the specification of ASI-T-350EB6FN/D active matrix TFT module. It is composed of a color TFT-LCD panel, driver ICs, FPC and a backlight unit. The 3.5" display area contains 320(RGB) x 240 pixels.

2. Application

Digital equipments which need color display, mobile phone, mobile navigator/video systems.

3. General Information

Item	Contents	Unit
Size	3.5	inch
Resolution	320(RGB) x 240	/
Interface	24 bits RGB	/
Technology type	a-Si TFT	/
Pixel pitch	0.219x0.219	mm
Pixel Configuration	R.G.B. Vertical Stripe	
Outline Dimension (W x H x D)	76.8x63.8x3.1	mm
Active Area	70.08 x 52.56	mm
Display Mode	Transmissive, Normally White	/
Backlight Type	LED	/
Driver IC	HX8238D	/

4. Outline Drawing

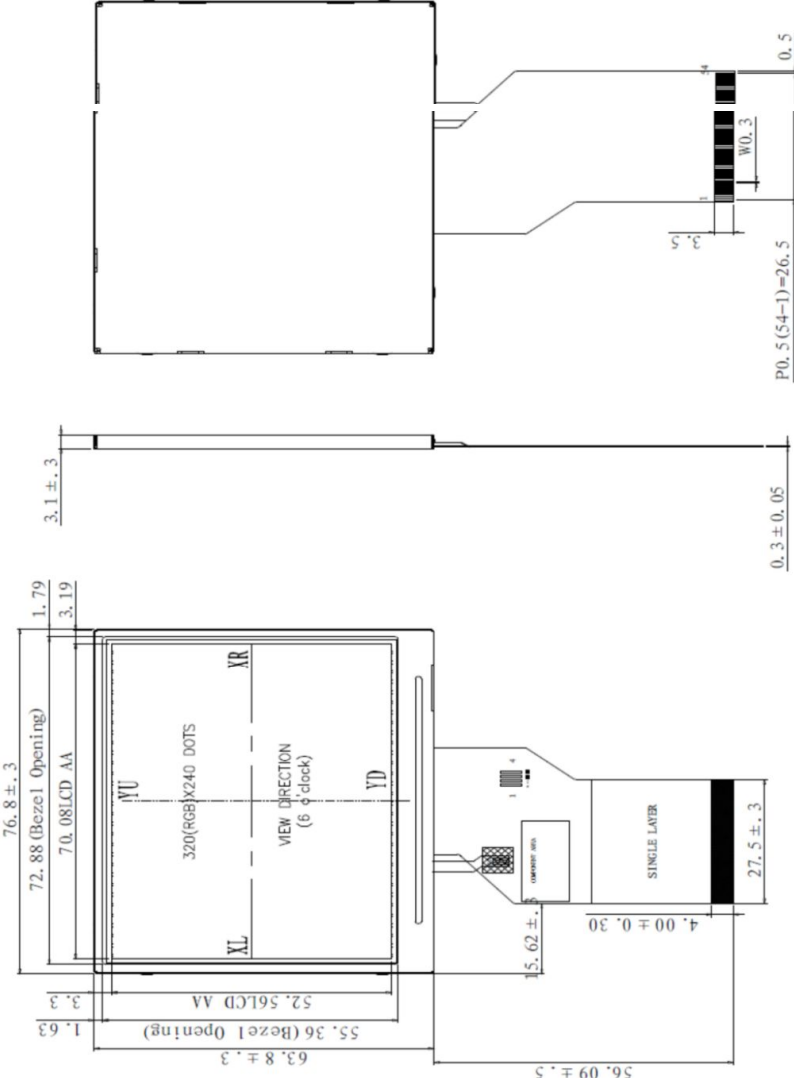

76.8 ± .3
72.88 (Bezel Opening)
70.08 LCD AA
3.19
3.1 ± .3
1.79
52.56 LCD AA
3.3
55.36 (Bezel Opening)
1.63
63.8 ± .3
56.09 ± .5
15.62 ± .5
4.00 ± 0.30
27.5 ± .3
XR
YD
VIEW DIRECTION
(6 o'clock)
320(RGB)X240 DOTS
SINGLE LAYER
P0.5 (54-1)=26.5
0.3 ± 0.05
0.5
W0.3

NO.	SYMBOL	NO.	SYMBOL
1	WR-	28	DB16
2	WR-	29	DB17
3	WR+	30	DB18
4	WR+	31	DB19
5	NC	32	DB20
6	NC	33	DB21
7	POL	34	DB22
8	/RESET	35	DB23
9	/CS	36	HSYNC
10	SCL	37	VSYNC
11	S01	38	DOTCLK
12	DB0	39	NC
13	DB1	40	NC
14	DB2	41	V10
15	DB3	42	V10
16	DB4	43	NC
17	DB5	44	NC
18	DB6	45	NC
19	DB7	46	NC
20	DB8	47	NC
21	DB9	48	NC
22	DB10	49	NC
23	DB11	50	NC
24	DB12	51	NC
25	DB13	52	DBN
26	DB14	53	GND
27	DB15	54	GND

电路图:
A1 ——— KI

NOTES:
1.DISPLAY TYPE: a-Si TFT
2.DISPLAY MODULE: Transmissive ,Normally White
3.OPERATIN TEMP: -10° C---+60° C
4.STORAGE TEMP: -20° C---+70° C
5.Backlight: LED
6. RoHS Compliant

DRAWN	BY:	TITLE:	SCALE:
CHECKED	BY:	DWG NO:	UNIT: mm
APPROVED	BY:	DWG NAME:	SHEET NO: OF
CONFIRMED	BY:		



5. Interface signals

No	Symbol	I/O	Description	Remarks
1	LED_Cathode	P	LED_Cathode	
2	LED_Cathode	P	LED_Cathode	
3	LED_Anode	P	LED_Anode	
4	LED_Anode	P	LED_Anode	
5	NC	-	No Connect	
6	NC	-	No Connect	
7	POL	-	Polarity signal to monitor VCOM signal	
8	RESET	I	Reset	
9	/CS	I	Chip select pin for serial interface.	
10	SCL	I	Clock input in for serial interface	
11	SDI	I/O	Data input pin for serial mode	
12	D00	I	Data 00	
13	D01	I	Data 01	
14	D02	I	Data 02	
15	D03	I	Data 03	
16	D04	I	Data 04	
17	D05	I	Data 05	
18	D06	I	Data 06	
19	D07	I	Data 07	
20	D08	I	Data 08	
21	D09	I	Data 09	
22	D10	I	Data 10	
23	D11	I	Data 11	
24	D12	I	Data 12	
25	D13	I	Data 13	
26	D14	I	Data 14	
27	D15	I	Data 15	
28	D16	I	Data 16	
29	D17	I	Data 17	
30	D18	I	Data 18	
31	D19	I	Data 19	



32	D20	I	Data 20	
33	D21	I	Data 21	
34	D22	I	Data 22	
35	D23	I	Data 23	
36	HSYNC	I	Horizontal Synchronous Signal	
37	VSYNC	I	Vertical Synchronous Signal	
38	DOTCLK	I	Dot-clock signal and oscillator source	
39	NC	-	No Connect	
40	NC	-	No Connect	
41	VDD	P	power supply (3.3V)	
42	VDD	P	power supply (3.3V)	
43	NC	-	No Connect	
44	NC	-	No Connect	
45	NC	-	No Connect	
46	NC	-	No Connect	
47	NC	-	No Connect	
48	NC	-	No Connect	
49	NC	-	No Connect	
50	NC	-	No Connect	
51	NC	-	No Connect	
52	DEN	I	Data enabling signal	
53	GND	P	Ground	
54	GND	P	Ground	

6. Absolute maximum Ratings

6.1. Electrical Absolute max. ratings

Parameter	Symbol	MIN	MAX	Unit	Remark
Supply Voltage	VDD	-0.3	5.0	V	

6.2. Environment Conditions

Item	Symbol	MIN	MAX	Unit	Remark
Operating Temperature	TOPR	-20	70	°C	
Storage Temperature	TSTG	-30	80	°C	

6.3. LED Backlight Absolute max. ratings

Item	Symbol	MIN	MAX	Unit	Remark
LED Forward Current	I _{LED}	--	25	mA	For each LED

7. Electrical Specifications

7.1 Electrical characteristics

GND=0V, Ta=25°C

Item	Symbol	MIN	TYP	MAX	Unit	Remark
Supply Voltage	VDD	3.0	3.3	3.6	V	
Input Signal Voltage	VIL	GND	--	0.1XVDD	V	
	VIH	0.8XVDD	--	VDD	V	
Output Signal Voltage	VOL	0	--	0.1VCC	V	
	VOH	0.9VCC	--	VCC	V	

7.2 LED Backlight

Ta=25°C

Item	Symbol	MIN	TYP	MAX	Unit	Remark
Forward Current	IF		20	25	mA	One LED
Forward Voltage	VF	3.0	3.2	3.4	V	
Power Consumption	--		384		mW	

Note 1: The figure below shows the connection of backlight LED.

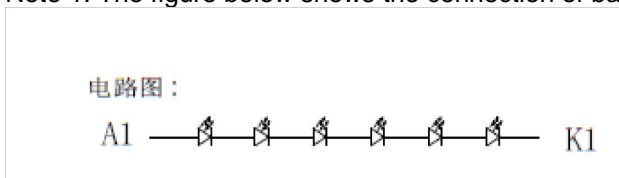

Note 2: One LED : IF =20 mA, VF =3.2V

7.3 Block Diagram

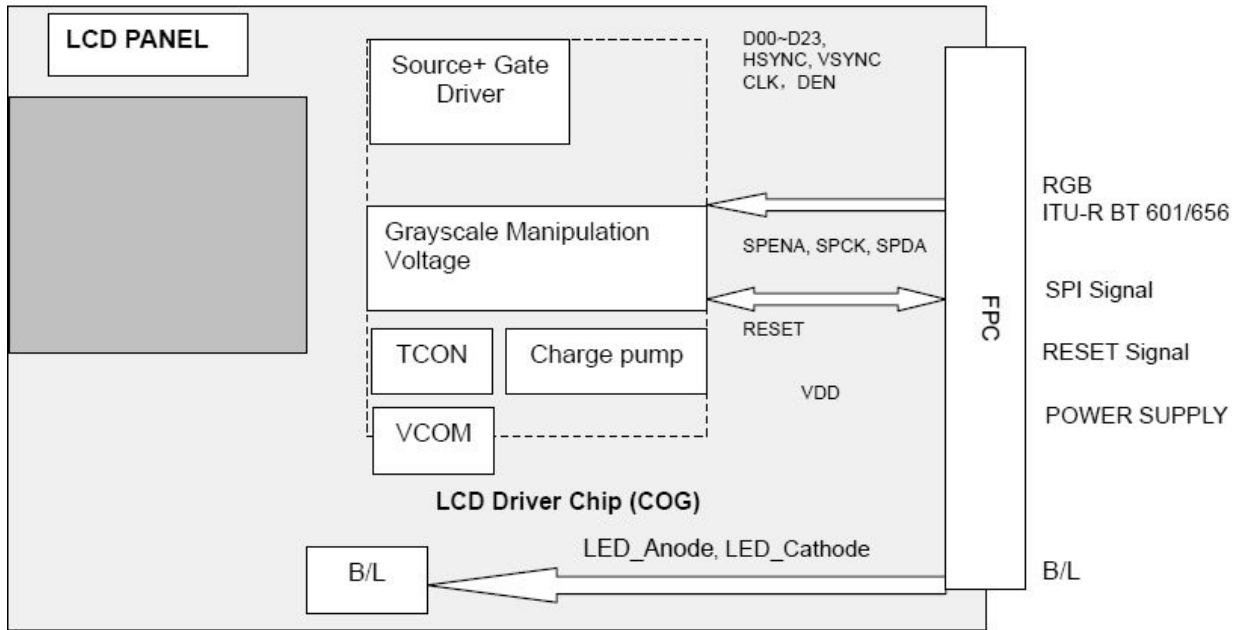

8. Command/AC Timing

8.1 Timing Parameter

8.1.1AC Electrical Characteristics (VDD=3.3V, GND= 0V, Ta=25°C)

Characteristics	Symbol	Min.		Typ.		Max.		Unit
		24-bit	8-bit	24-bit	8-bit	24-bit	8-bit	
DOTCLK Frequency	fDOTCLK	-	-	6.5	19.5	10	30	MHz
DOTCLK Period	tDOTCLK	100	33.3	154	51.3	-	-	ns
Vertical Sync Setup Time	tvsys	20	10	-	-	-	-	ns
Vertical Sync Hold Time	tvsyh	20	10	-	-	-	-	ns
Horizontal Sync Setup Time	thsys	20	10	-	-	-	-	ns
Horizontal Sync Hold Time	thsyh	20	10	-	-	-	-	ns
Phase difference of Sync Signal Falling Edge	thv	1		-		240		tDOTCLK
DOTCLK Low Period	tCKL	50	15	-	-	-	-	ns
DOTCLK High Period	tCKH	50	15	-	-	-	-	ns
Data Setup Time	tds	12	10	-	-	-	-	ns
Data hold Time	tdh	12	10	-	-	-	-	ns
Reset pulse width	tRES	10		-		-		s

Note: External clock source must be provided to DOTCLK pin of HX8238-D. The driver will not operate if absent of the clocking signal.

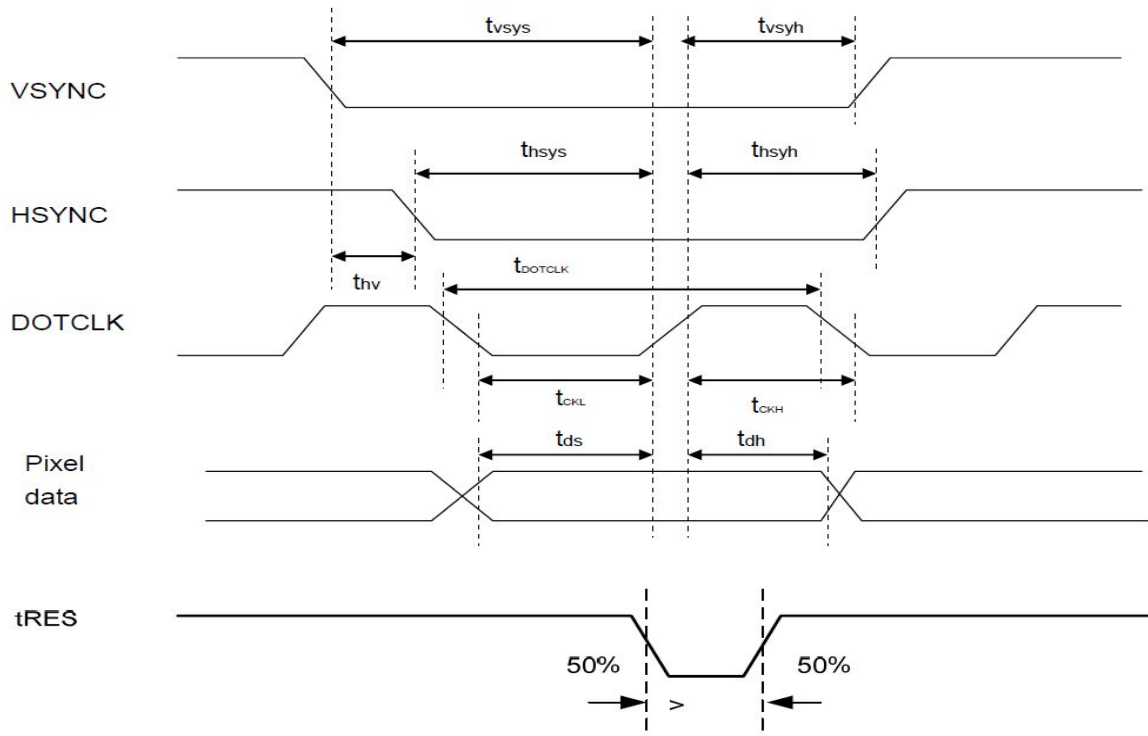



8.2 24 bit RGB mode for 320RGB x 240

Characteristics	Symbol	Min.		Typ.		Max.		Unit	
		24-bit	8-bit	24-bit	8-bit	24-bit	8-bit		
DOTCLK Frequency	fDOTCLK	-	-	6.5	19.5	10	30	MHz	
DOTCLK Period	tDOTCLK	100	33.3	154	51.3	-	-	ns	
Horizontal Frequency (Line)	fH	-		14.9		22.35		KHz	
Vertical Frequency (Refresh)	fV	-		60		90		Hz	
Horizontal Back Porch	tHBP	-	-	68	204	-	-	tDOTCLK	
Horizontal Front Porch	tHFP	-	-	20	60	-	-	tDOTCLK	
Horizontal Data Start Point	tHBP	-	-	68	204	-	-	tDOTCLK	
Horizontal Blanking Period	tHBP + tHFP	52	146	88	264	180	960	tDOTCLK	
Horizontal Display Area	HDISP	-	-	320	960	-	-	tDOTCLK	
Horizontal Cycle	Hcycle	372	1106	408	1224	500	1920	tDOTCLK	
Vertical Back Porch	tVBP	-	-	18		-		Lines	
Vertical Front Porch	tVFP	-	-	4		-		Lines	
Vertical Data Start Point	tVBP	-	-	18		-		Lines	
Vertical Blanking Period	NTSC	tVBP + tVFP	10		22		47		Lines
	PAL		20		33		120		
	PAL		12		25		112		
Vertical Display Area	NTSC	VDISP	-		240		-		Lines
	PAL				280(PALM=0)				
	PAL				288(PALM=1)				
Vertical Cycle	NTSC	Vcycle	250		262		287		Lines
	PAL		300		313		400		

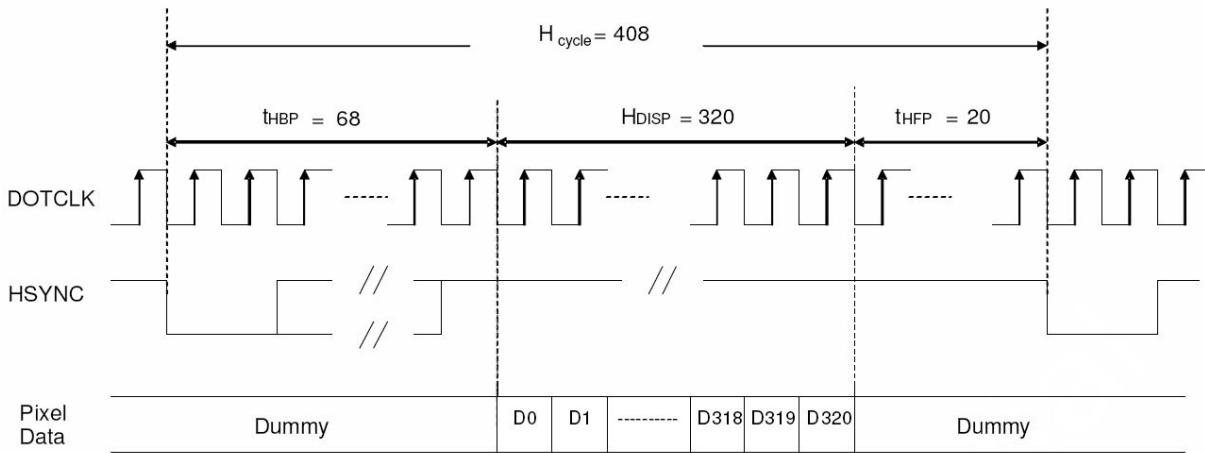

a) Horizontal Data Transaction Timing

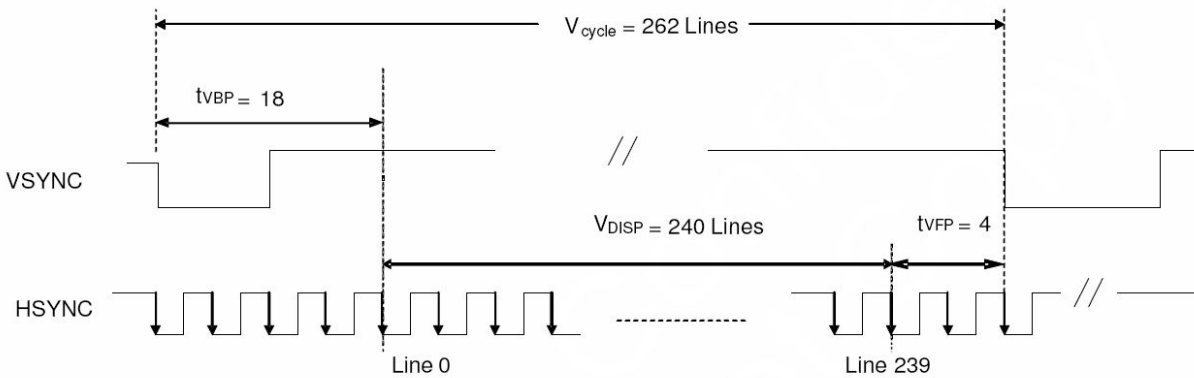

b) Vertical Data Transaction Timing

8.38 bit RGB mode for 320RGB x 240

Characteristics	Symbol	Min.		Typ.		Max.		Unit
		24-bit	8-bit	24-bit	8-bit	24-bit	8-bit	
DOTCLK Frequency	fDOTCLK	-	-	6.5	19.5	10	30	MHz
DOTCLK Period	tDOTCLK	100	33.3	154	51.3	-	-	ns
Horizontal Blanking Period	$t_{HBP} + t_{HFP}$	52	146	88	264	180	960	tDOTCLK
Horizontal Display Area	HDISP	-	-	320	960	-	-	tDOTCLK
Horizontal Cycle	Hcycle	372	1106	408	1224	500	1920	tDOTCLK
Vertical Blanking Period	$t_{VBP} + t_{VFP}$	2		-		47		Lines
Vertical Display Area	VDISP	-		240		-		Lines
Vertical Cycle	Vcycle	242		-		287		Lines

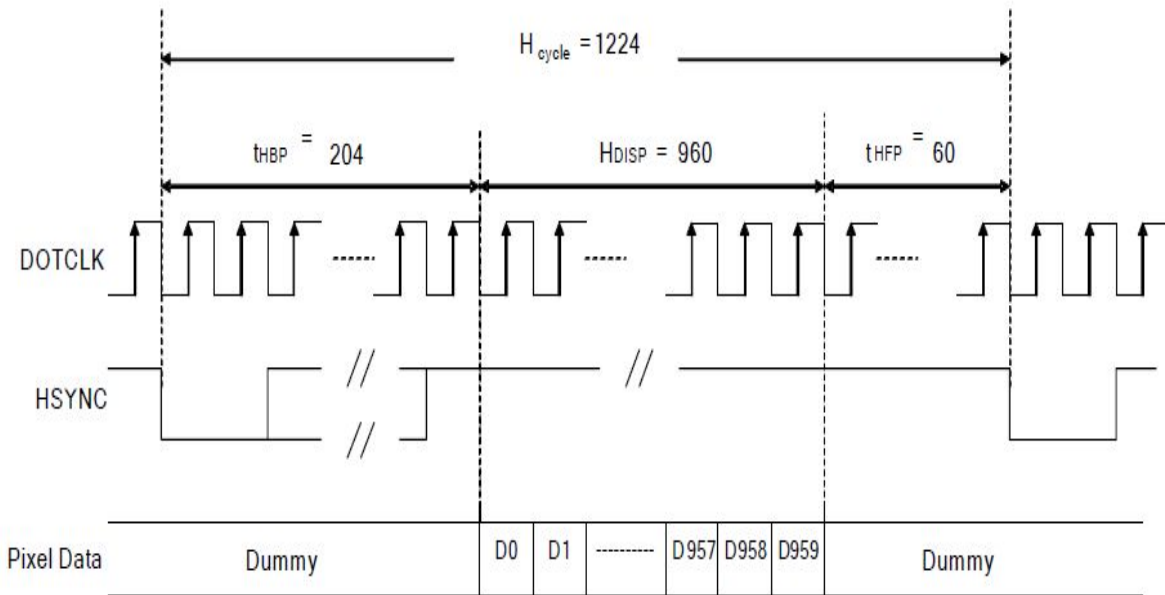

(1) Horizontal Data Transaction Timing

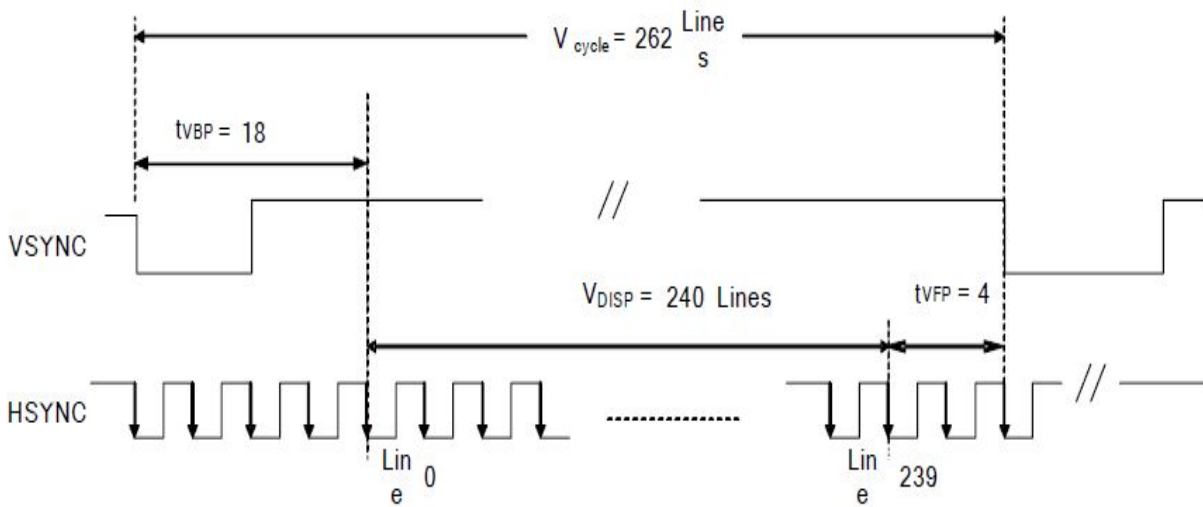

(2) Vertical Data Transaction Timing

8.4 Signal timing DE only mode

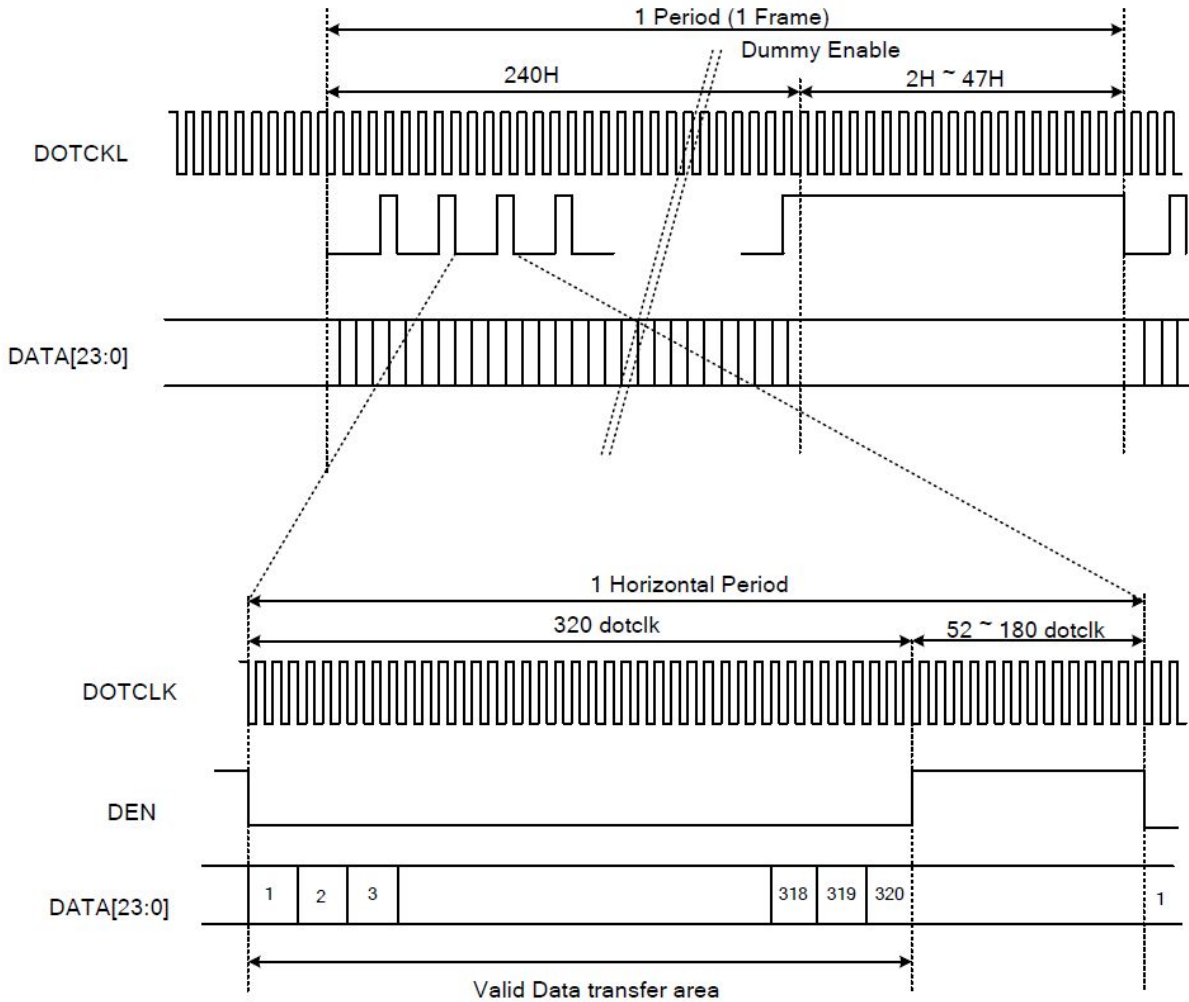

8.5 Color mode conversion timing

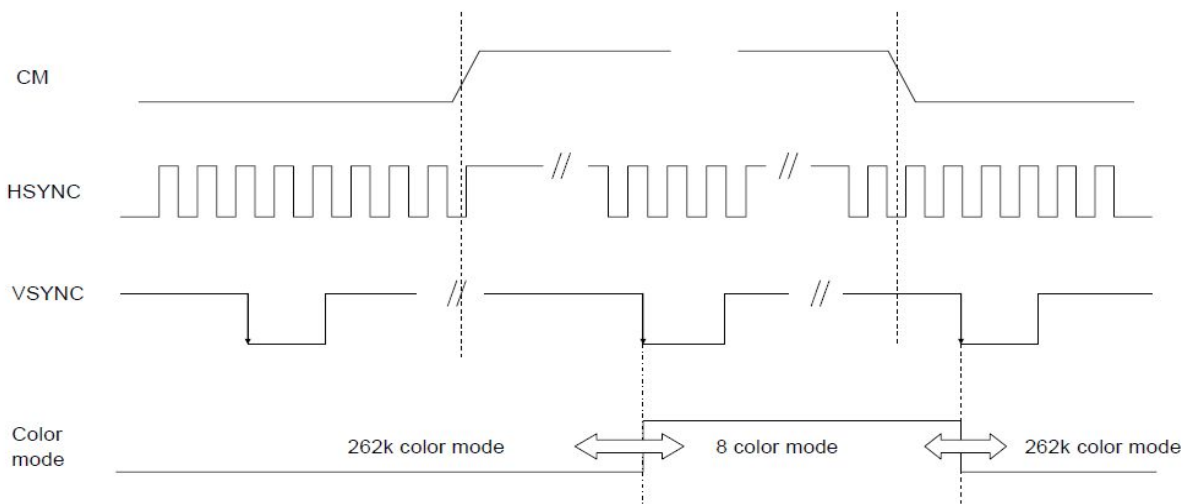

Note: The color mode conversion starts at the first falling edge of VSYNC after stage change of CM.

8.6 power on sequence

Characteristics	Symbol	Spec.			Unit
		Min.	Typ.	Max.	
VCI / VDDIO on to falling edge of SHUT	tp-shut	1	-	-	s
DOTCLK to falling edge of SHUT	tclk-shut (Note 1)	1	-	-	clk
Falling edge of SHUT to display start -1 line: 408 clk -1 frame: 262 line -DOTCLK = 6.5MHz	tshut-on (Note 2)	-	-	14	frame

Note: (1) It is necessary to input DOTCLK before the falling edge of SHUT.
 (2) Display starts at 14th falling edge of VSTNC after the falling edge of SHUT. The display starts at the falling edge of VSYNC which is determined by BLT[1:0] of R04h.

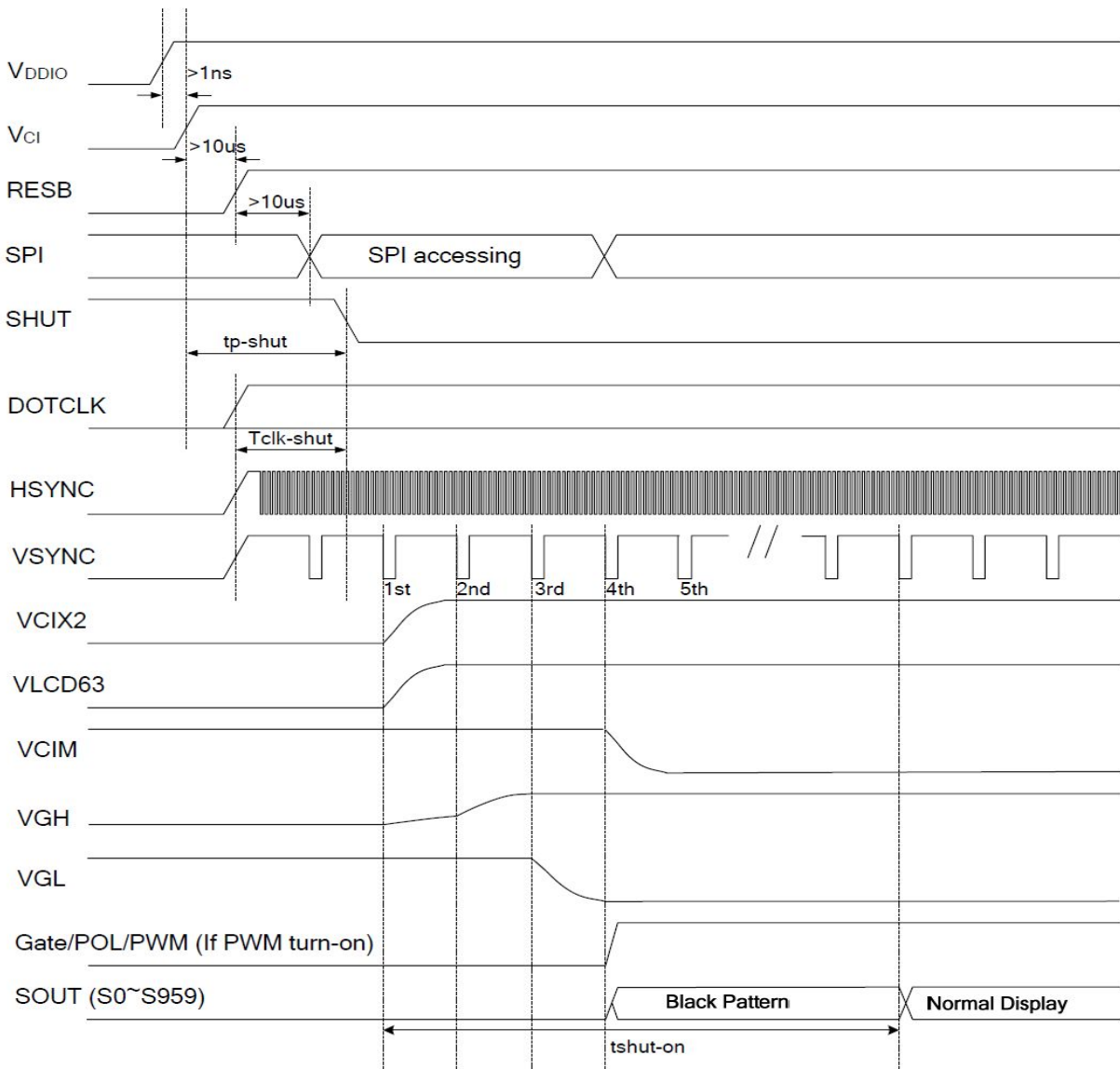

8.7 power off sequence

Characteristics	Symbol	Spec.			Unit
		Min.	Typ.	Max.	
Rising edge of SHUT to display off -1 line: 408 clk -1 frame: 262 line -DOTCLK=6.5MHz	tshut-off	-	-	6	frame

Note: DOTCLK must be maintained at least 6 frames after the rising edge of SHUT.
 Display become off at the 6th falling edge of VSYNC after the rising edge of SHUT.
 If RESET signal is necessary for power down, provide it after the 6-frames-cycle of the SHUT period.

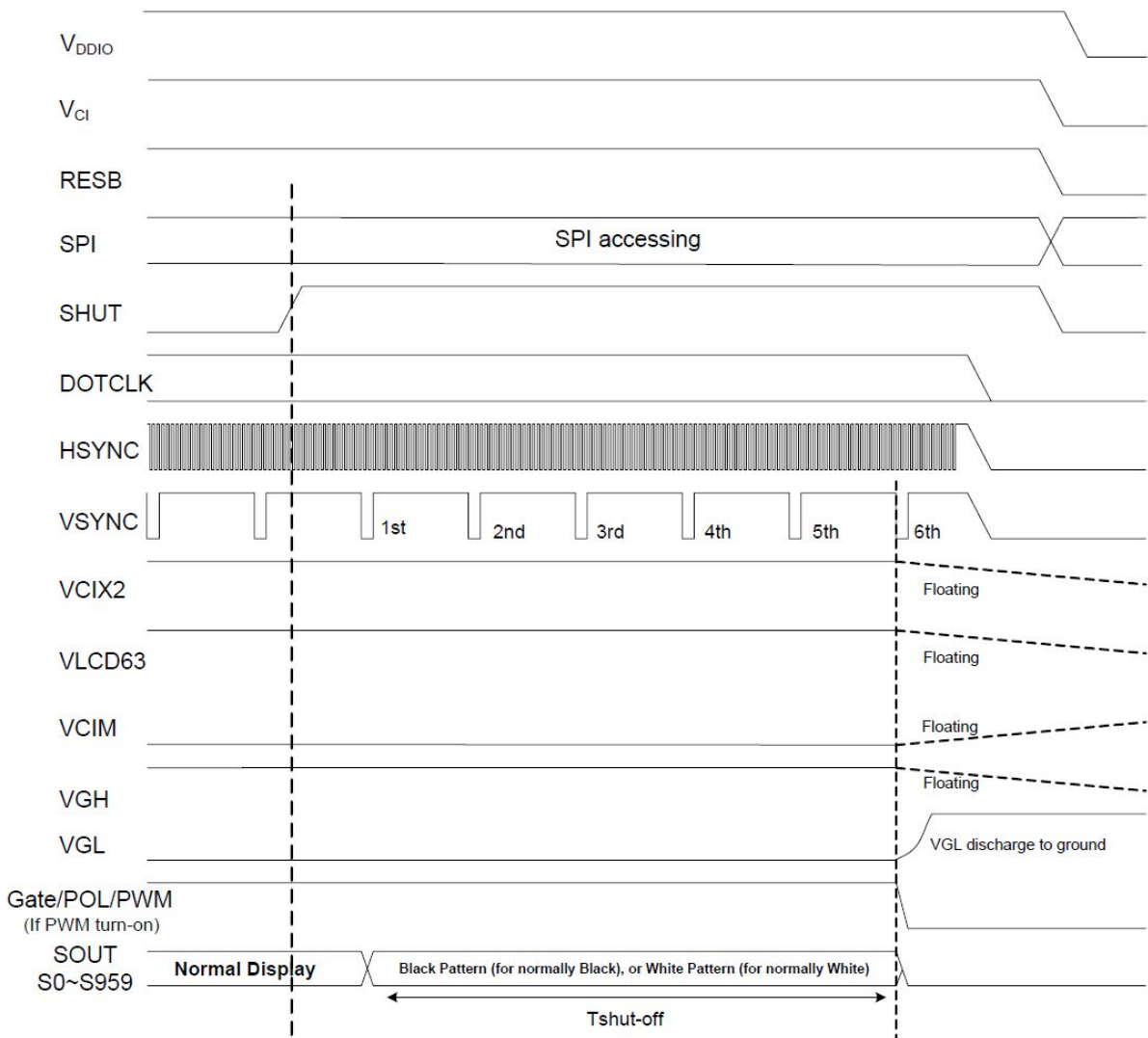

9. Optical Specification

Ta=25°C

Item	Symbol	Condition	Min	Typ.	Max.	Unit	Remark
Contrast Ratio	CR	$\theta=0^\circ$	-	350	-		Note1 Note2
Response Time	Ton/ Toff	25°C	-	50	80	ms	Note1 Note3
View Angles	θT	$CR \cong 10$	-	50	-	Degree	Note 4
	θB		-	60	-		
	θL		-	60	-		
	θR		-	60	-		
Chromaticity	White	x		0.31			Note5, Note1
		y		0.35			
NTSC	S			60		%	Note5
Luminance	L		-	600	-	cd/m ²	Note1 Note6
Uniformity	U		75	80	-	%	Note1 Note7

Test condition: $V_F=3.2V$, $I_F=20mA$ (LED current), the ambient temperature is 25°C.

Note 1: Definition of optical measurement system.

Temperature = 25°C(±3°C)

LED back-light: ON, Environment brightness < 150 lx

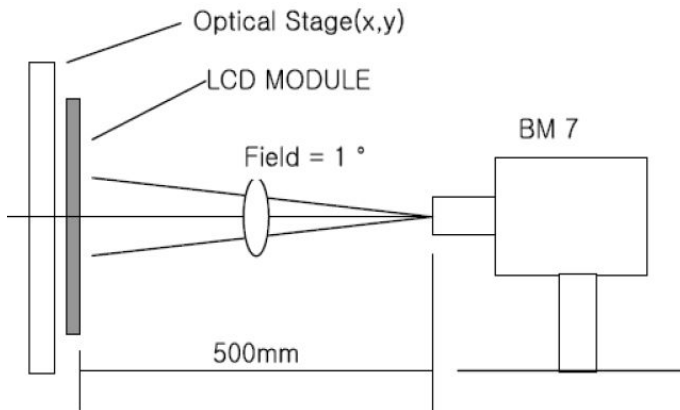

Note 2: Contrast ratio is defined as follow:

$$\text{Contrast Ratio} = \frac{\text{Surface Luminance with all white pixels}}{\text{Surface Luminance with all black pixels}}$$

Note 3: Response time is defined as follow:

Response time is the time required for the display to transition from black to white (Rise Time, T_r) and from white to black(Decay Time, T_f).

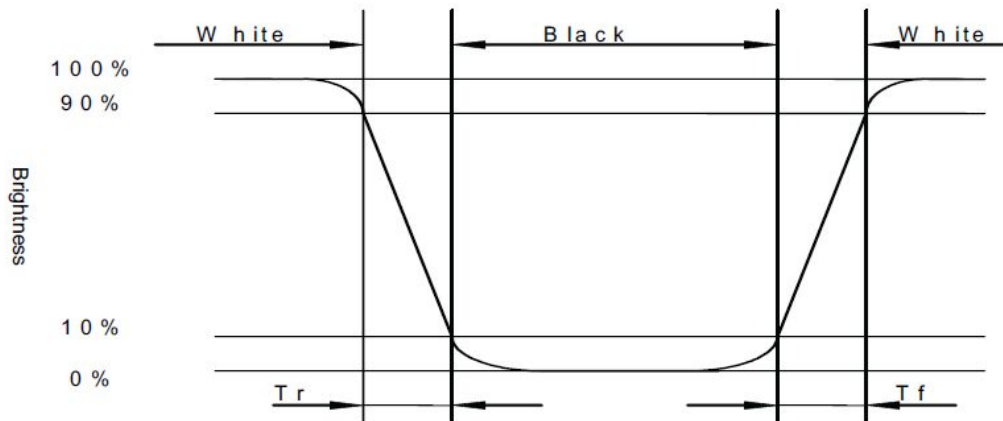

Note 4: Viewing angle range is defined as follow:

Viewing angle is measured at the center point of the LCD.

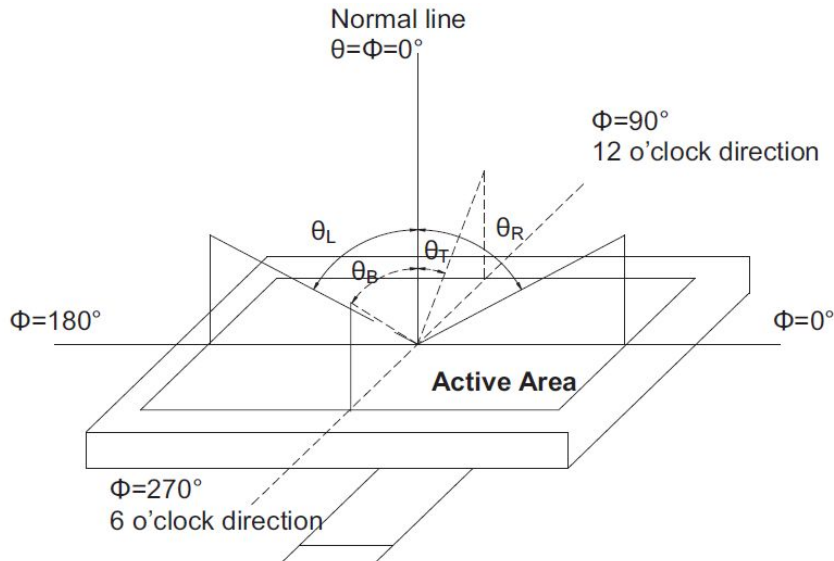

Note 5: Color chromaticity is defined as follow: (CIE1931)

Color coordinates measured at center point of LCD.

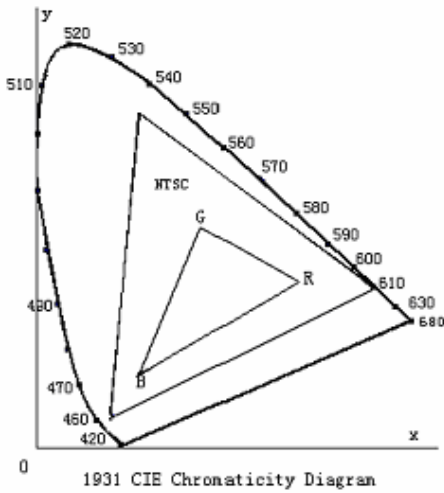

$$S = \frac{\text{area of RGB triangle}}{\text{area of NTSC triangle}} \times 100\%$$

Note 6: Luminance is defined as follow:

Luminance is defined as the brightness of all pixels “White” at the center of display area on optimum contrast.

Note 7: Luminance Uniformity is defined as follow:

Active area is divided into 9 measuring areas (Refer Fig. 2). Every measuring point is placed at the center of each measuring area.

$$\text{Uniformity (U)} = \frac{\text{Minimum Luminance(brightness) in 9 points}}{\text{Maximum Luminance(brightness) in 9 points}}$$

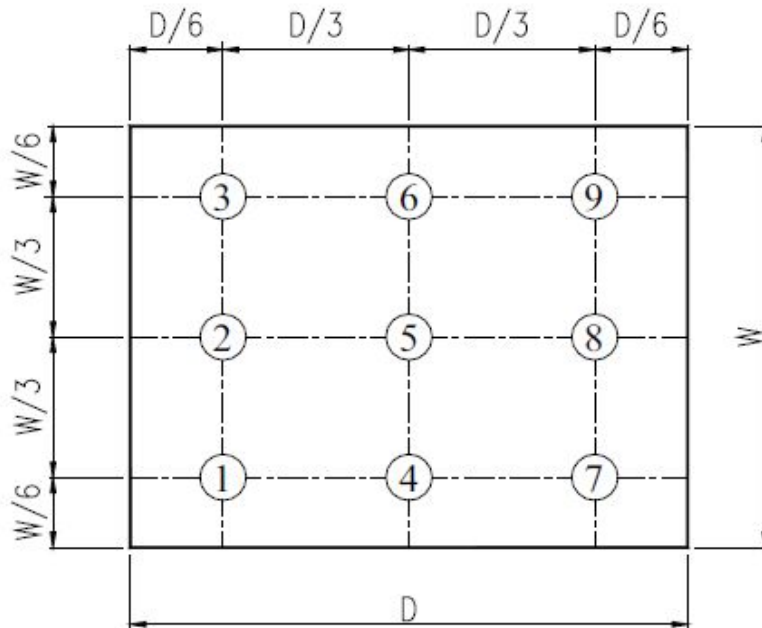

Fig. 2 Definition of uniformity

10. Environmental / Reliability Tests

No	Test Item	Condition	Judgment criteria
1	High Temp Operation	Ts=+70°C, 120hrs	Per table in below
2	Low Temp Operation	Ta=-20°C, 120hrs	Per table in below
3	High Temp Storage	Ta=+80°C, 120hrs	Per table in below
4	Low Temp Storage	Ta=-30°C, 120hrs	Per table in below
5	High Temp & High Humidity Storage	Ta=+60°C, 90% RH 120 hours	Per table in below (polarizer discoloration is excluded)
6	Thermal Shock (Non-operation)	-30°C 30 min~+80°C 30 min, Change time:5min, 10 Cycles	Per table in below
7	ESD (Operation)	C=150pF, R=330Ω , 5points/panel Air:±8KV, 5times; Contact:±4KV, 5 times;	Per table in below
8	Vibration (Non-operation)	Frequency range:10~55Hz, Stroke:1.5mm Sweep:10Hz~55Hz~10Hz 2 hours for each direction of X.Y.Z.	Per table in below
9	Shock (Non-operation)	60G 6ms, ±X,±Y,±Z 3times, for each direction	Per table in below
10	Package Drop Test	Height:80 cm, 1 corner, 3 edges, 6 surfaces	Per table in below

INSPECTION	CRITERION(after test)
Appearance	No Crack on the FPC, on the LCD Panel
Alignment of LCD Panel	No Bubbles in the LCD Panel No other Defects of Alignment in Active area
Electrical current	Within device specifications
Function / Display	No Broken Circuit, No Short Circuit or No Black line No Other Defects of Display

11. Precautions for Use of LCD Modules

11.1 Safety

The liquid crystal in the LCD is poisonous. Do not put it in your mouth. If the liquid crystal touches your skin or clothes, wash it off immediately using soap and water.

11.2 Handling

- A. The LCD and touch panel is made of plate glass. Do not subject the panel to mechanical shock or to excessive force on its surface.
- B. Do not handle the product by holding the flexible pattern portion in order to assure the reliability
- C. Transparency is an important factor for the touch panel. Please wear clear finger sacks, gloves and mask to protect the touch panel from finger print or stain and also hold the portion outside the view area when handling the touch panel.
- D. Provide a space so that the panel does not come into contact with other components.
- E. To protect the product from external force, put a covering lens (acrylic board or similar board) and keep an appropriate gap between them.
- F. Transparent electrodes may be disconnected if the panel is used under environmental conditions where dew condensation occurs.
- G. Property of semiconductor devices may be affected when they are exposed to light, possibly resulting in IC malfunctions.
- H. To prevent such IC malfunctions, your design and mounting layout shall be done in the way that the IC is not exposed to light in actual use.

11.3 Static Electricity

- A. Ground soldering iron tips, tools and testers when they are in operation.
- B. Ground your body when handling the products.
- C. Power on the LCD module before applying the voltage to the input terminals.
- D. Do not apply voltage which exceeds the absolute maximum rating.
- E. Store the products in an anti-electrostatic bag or container.

11.4 Storage

- A. Store the products in a dark place at $+25^{\circ}\text{C} \pm 10^{\circ}\text{C}$ with low humidity (40% RH to 60% RH). Don't expose to sunlight or fluorescent light.
- B. Storage in a clean environment, free from dust, active gas, and solvent.

11.5 Cleaning

- A. Do not wipe the touch panel with dry cloth, as it may cause scratch.
- B. Wipe off the stain on the product by using soft cloth moistened with ethanol. Do not allow ethanol to get in between the upper film and the bottom glass. It may cause peeling issue or defective operation. Do not use any organic solvent or detergent other than ethanol.

11.6 Cautions for installing and assembling

Bezel edge must be positioned in the area between the Active area and View area. The bezel may press the touch screen and cause activation if the edge touches the active area. A gap of approximately 0.5mm is needed between the bezel and the top electrode. It may cause unexpected activation if the gap is too narrow. There is a tolerance of 0.2 to 0.3mm for the outside dimensions of the touch panel and tail. A gap must be made to absorb the tolerance in the case and connector.

