



ASI-T-3163353A0SMN/W

No	Item	Specification	Remark
1	Type	Transflective	--
2	Hold Mode	Normally White	--
3	Screen Size	3.16inch	--
4	Resolution	336 x536	--
5	Active Area	42.672 (W) x 68.072 (H) (mm)	--
6	Dot Size	0.127(W) x 0.127(H) (mm)	--
7	Weight	TBD	g
8	Module Dimension	47.02(W) x 76.0(H) x 0.705(D) mm	--



RECORD OF REVISION

DATE	REV.	PAGE	SUMMARY
2023/1/12	2 (<u>Δ</u>)	8	1.Modify the Outline Dimension, Please refer to <u>Δ</u>

3. General specifications

3.1 General specifications

It is a color active matrix TFT (Thin Film Transistor) liquid crystal display (LCD) that uses the amorphous silicon TFT as a switching devices. This model is composed of a Transflective type TFT-LCD Panel and a driver circuit.

4. Mechanical data

No	Item	Specification	Remark
1	Type	Transflective	--
2	Hold Mode	Normally White	--
3	Screen Size	3.16inch	--
4	Resolution	336 x536	--
5	Active Area	42.672 (W) x 68.072 (H) (mm)	--
6	Dot Size	0.127(W) x 0.127(H) (mm)	--
7	Weight	TBD	g
8	Module Dimension	47.02(W) x 76.0(H) x 0.705(D) mm	--

5. Absolute maximum ratings

5.1 Electrical absolute maximum ratings

(1) TFT-LCD Panel Absolute Maximum Ratings

Ta=25°C

Item	Symbol	Condition	Standard Value		Unit	Remark
			Min.	Max.		
Analog power supply	VDDA	VSSA=0V	-0.3	5.8	V	--
Digital power supply	VDD	VSS=0V	-0.3	5.8	V	--
Input signal terminal Voltage (high)	VIH	--	--	VDD	V	--
Input signal terminal Voltage (low)	VIL	--	-0.3	--	V	--

* If the LSI is used above these absolute maximum ratings, it may become permanently damaged. Using the LSI within the following electrical characteristics limit is strongly recommended for normal operation. If these electrical characteristic conditions are also exceeded, the LSI will malfunction and cause poor reliability.

5.2 Environmental absolute maximum ratings

Item	Symbol	Min.	Max.	Unit	Remark
Operation temperature range	Top	-20	70	°C	Ambient
Storage temperature range	Tst	-30	80	°C	Ambient

- (1) Corrosive gas environment is not acceptable.
- (2) TFT-LCD color will change slightly depending on environment temperature.
This phenomenon is reversible.

6. Electrical characteristics

(1)TFT-LCD Module

Ta=25°C, VDD=5V

Item	Symbol	Min.	Typ.	Max.	Unit	Remark
Analog power supply	VDDA	4.8	5.0	5.5	V	--
Digital power supply	VDD	4.8	5.0	5.5	V	NOTE(1)
Hight level input voltage	VIH	2.7	3.0	VDD NOTE(3)	V	NOTE(2)
Low level input voltage	VIL	VSS	VSS	VSS+0.15	V	
Power Consumption (Average) Measurement Condition (1)	PDD	--	30	330	uW	NOTE(4) NOTE(6)
Power Consumption (Average) Measurement Condition (2)	PDD	--	250	750	uW	NOTE(5) NOTE(6)

NOTE(1) : Also applicable to EXTMODE="H".

NOTE(2) : Applies to SCLK, SI, SCS , DISP, EXTCOMIN.

NOTE(3) : Can operate below VDD voltage, however, operation around 3V is recommended.

NOTE(4) : Hold mode (no display data update), Display pattern: Black display.

NOTE(5) : Data update mode (with display data update:1Hz) Common inversion with
VDD=5V、VDDA=5V、fSCLK=1MHz、fSCS=1Hz, Display pattern:
Vertical stripe display.

NOTE(6) : This is value in steady condition, not the value of peak power at the time of COM operation. Some marging for power supply is recommended. We recommend capacitor for VDD and VDDA. (If VDD and VDDA are on separate systems, we recommend capacitor for each.)

7. Optical characteristics

Ta=25°C

Item	Symbol	Condition	Min.	Typ.	Max.	Unit	Note	
Contrast Ratio	C/R	$\theta=0^\circ$ Normal	20	35	--	--	(1)	
Response Time	Tr	viewing angle	--	10	--	ms	(2)	
	Tf	At the center of panel	--	20	--	ms	(2)	
Viewing Angle	Top	θ_U	C/R \geq 2 Backlight On	40	60	--	deg.	(3)
	Bottom	θ_D		40	60	--		
	Left	θ_L		40	60	--		
	Right	θ_R		40	60	--		

Note 1: Definition of contrast Ratio (C/R)

$$C/R = \frac{\text{Brightness When LCD is at "White" State}}{\text{Brightness When LCD is at "Black" State}}$$

Note 2: Definition of response time

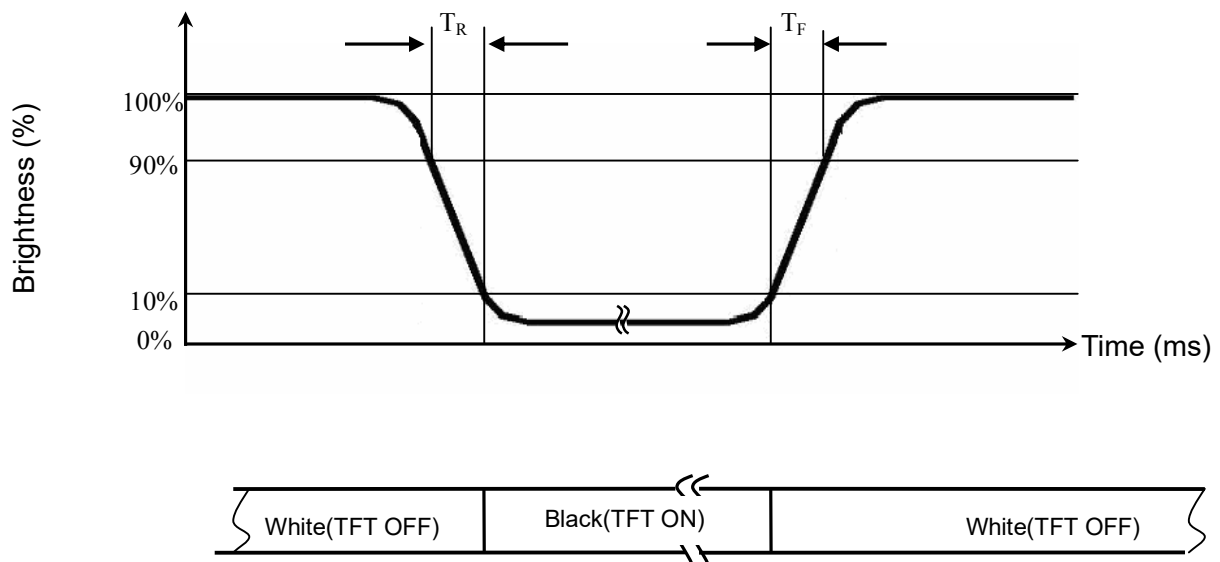

Note 3: Definition of viewing angle

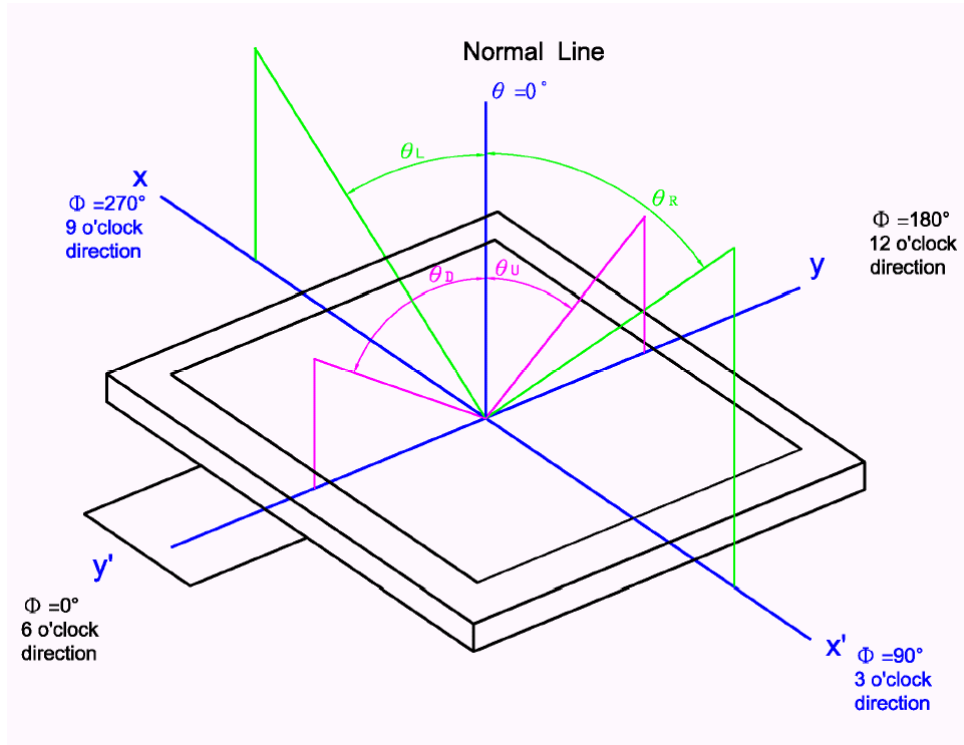

8. Outline dimension

- NOTE:
 1. UNIT: mm
 2. SCALE: NTS
 3. NOT SPECIFIED TOLERANCE : ±0.3

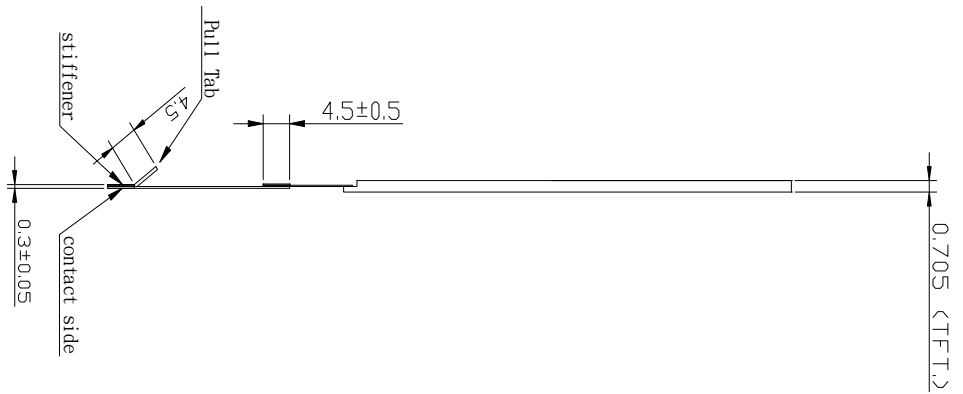
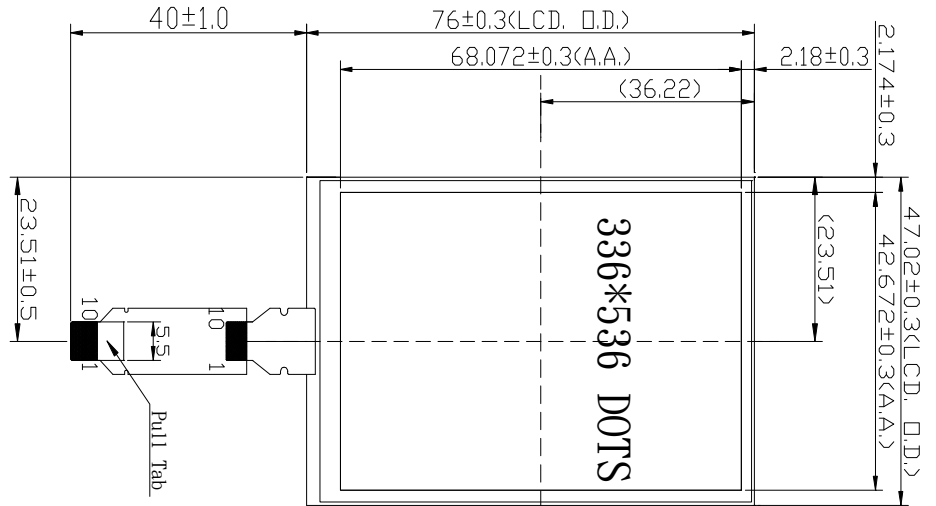

"A" detail:

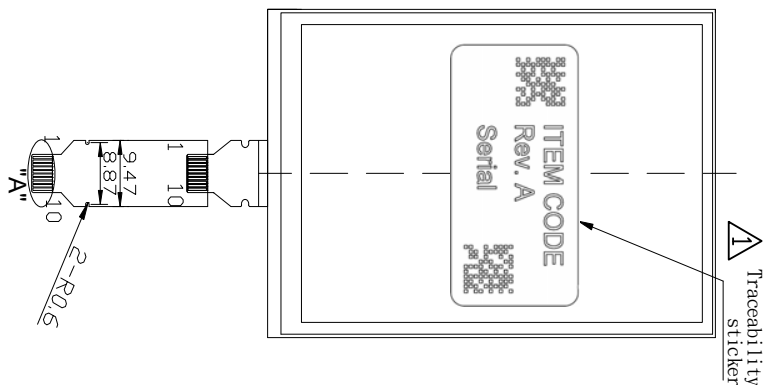
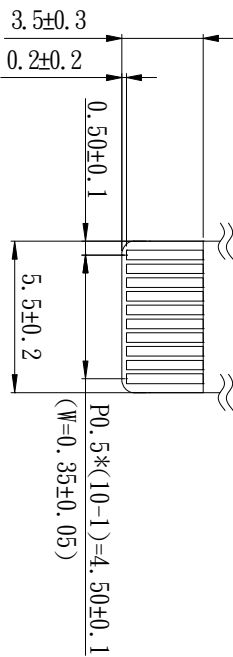

9. Input Terminal Pin Assignment

9.1 Input Signal & Power

Pin no	Symbol	Description	Remark
1	SCLK	Serial clock signal	I
2	SI	Serial input signal	I
3	SCS	Chip select signal	I
4	EXTCOMIN	External COM inversion signal input (“H” : active)	I
5	DISP	Display ON/OFF signal	I NOTE(2)
6	VDDA	Analog power supply	P
7	VDD	Digital power supply	P
8	EXTMODE	COM inversion mode switch terminal	I NOTE(1)
9	VSS	Digital ground	P
10	VSSA	Analog ground	P

NOTE(1) : ”H”=EXTCOMIN signal enabled. “L”=Serial input flag enabled.

When “H”, connect EXTMODE to VDD.

When “L”, connect EXTMODE to VSS.

NOTE(2) : ON/OFF for LCD display only. Memory data is maintained.

When “H”, displays with memory data.

When “L”, displays all white with memory data maintained.

NOTE(3) : Recommended Circuit

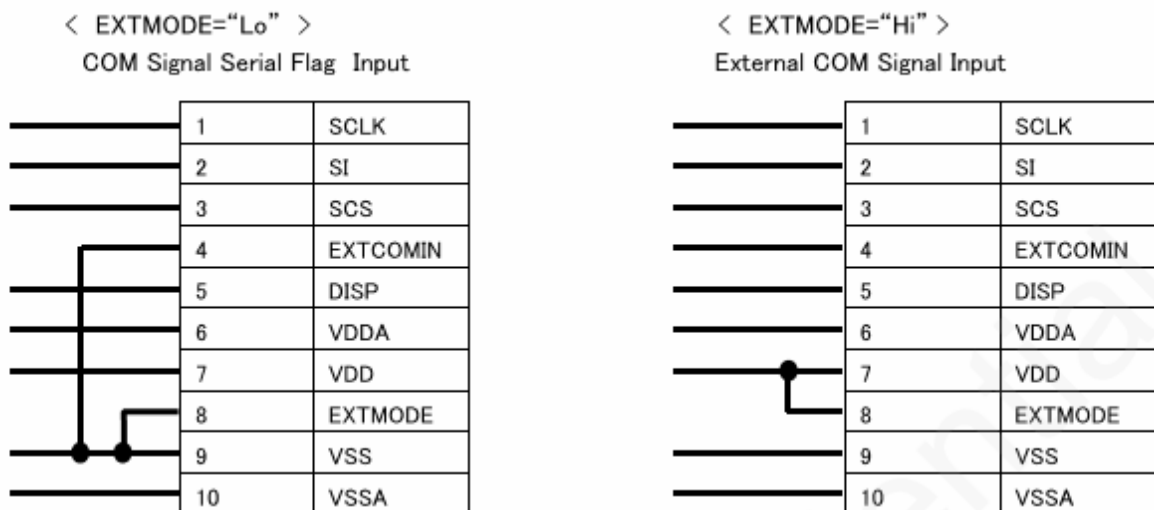

10. External Circuit Example

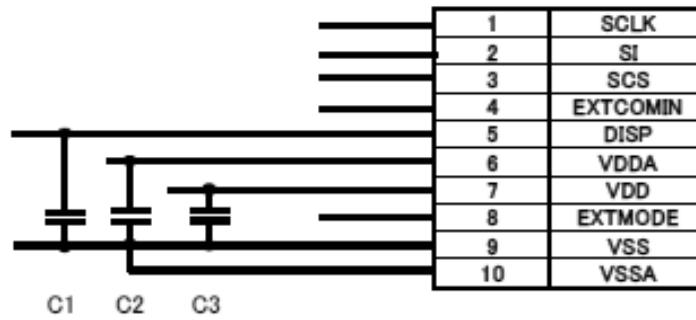

Recommended External Circuit

< Recommended capacity value > ⌘

C1 : DISP - VSS : rank B 560pF Ceramic capacitor⌘

The recommended minimum capacitance value on DISP is 560pF,⌘

However, it should be adjusted to ensure that the DISP rise time limit is not exceeded.⌘

⌘

C2 : VDDA- VSSA : rank B 1.0 μF Ceramic capacitor

C3 : VDD - VSS : rank B 1.0 μF Ceramic capacitor⌘

※Above circuit and parts are only recommendation.

For actual use, please evaluate their conformity with your system and design.

(Capacitor pressure resistance can be larger than resistance indicated above.)

11. Timing characteristics

11.1 Power Supply Sequence

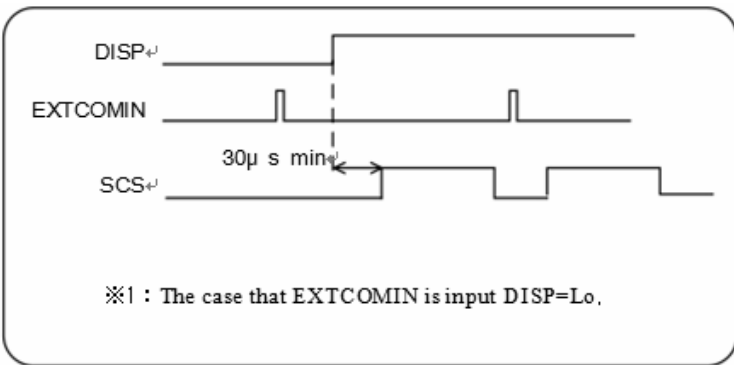
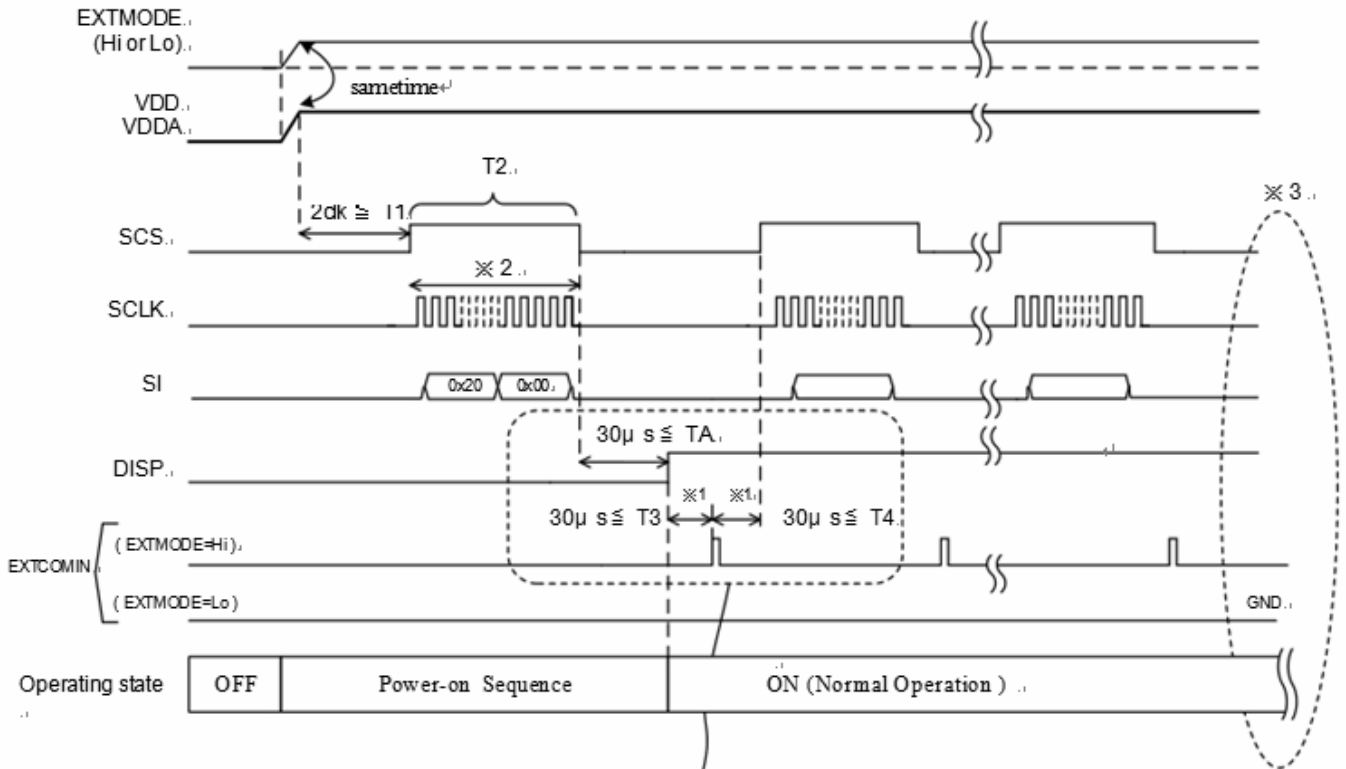

T_1 :

Please start the Signal transmission after a power supply was stable.

T_A :

Please set DISP to High Level after the completion of initialization.

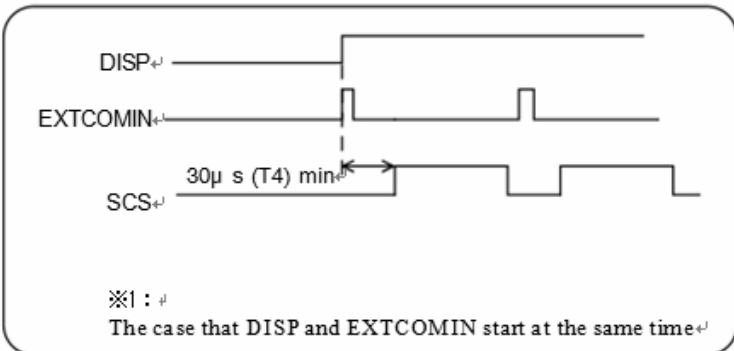

※Refer to timing chart and AC timing characteristics for detail

※1 TA and T3 may be opposite

(however, TCOM polarity inversion will not occur even with EXTCOMIN between DISP="Lo".)

Also, when DISP and EXTCOMIN are simultaneously started up, allow 30 μ s or more before SCS starts up (It may be less than 60 μ s).

※2 Setting value for pixel memory initialization

SCS=Driving accordingly to clear pixel internal memory method

(use all clear flag or write all screen white) S1=M2 (all clear flag) = "Hi" or write white
SCLK: Normal Driving

※3 One besides control Signal(DISP,EXTMODE,EXTCOMIN) · Make all terminals "L" while it does not communicate

[ON Sequence]

(1)VDD and VDDA rise time (depends on IC)

(2) Pixel memory initialization

T2:1 time or more Initialize with M2 (all clear flag) or write all screen white.

(3) Release time for initialization of TCOM latch

T3: 30 μ s or more

Time required to release COM related latch circuit initialization which is initializing using DISP signals

(4) TCOM polarity initialization time T4: 30 μ s or more

Time required initializing TCOM polarity accordingly to EXTCOMIN input

[Normal Operation]

Duration of normal driving

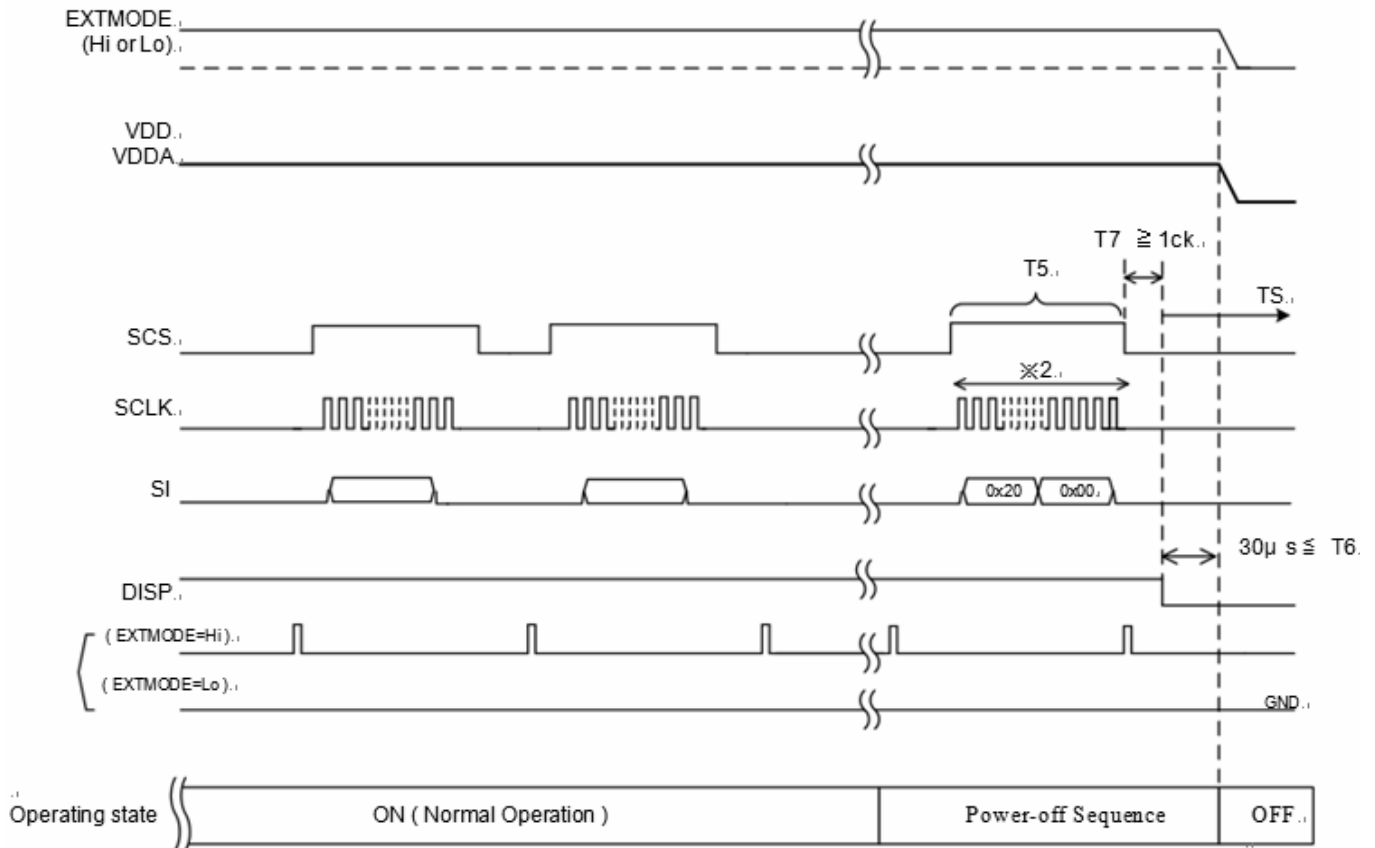

TS : Off control

Please turn off a power supply after making all the control signals into “Low Level”, and passing the time of T6.

[Off Sequence]

(5) Pixel memory initialization T5: Same (2)

(6) VA, VB, VCOM initialization time T6: 30µs or more

(7) VDD and VDDA falling time (Depends on IC)

【Remark】 Precautions at the time of power on and power off

※1) When power on, VDD and VDDA are same time or VDD should be faster than the VDDA.

※2) When power off, VDD and VDDA are same time or VDDA should be faster than the VDD

11.2 Input Signal Basic Characteristics

SCS, SI, SCLK signal

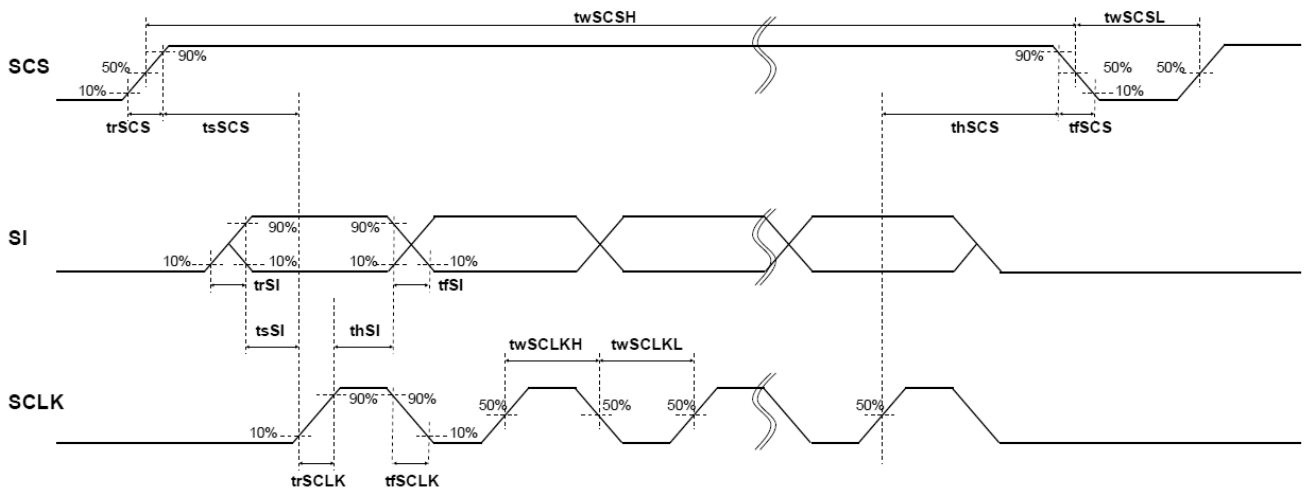

EXTCOMIN signal

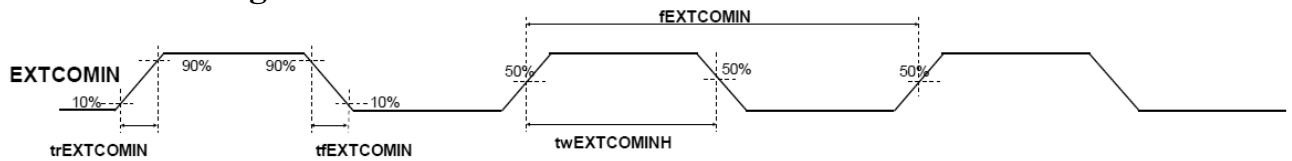

DISP signal

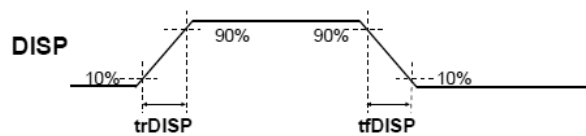

99 COM signal serial input (EXTMODE="Lo")^e

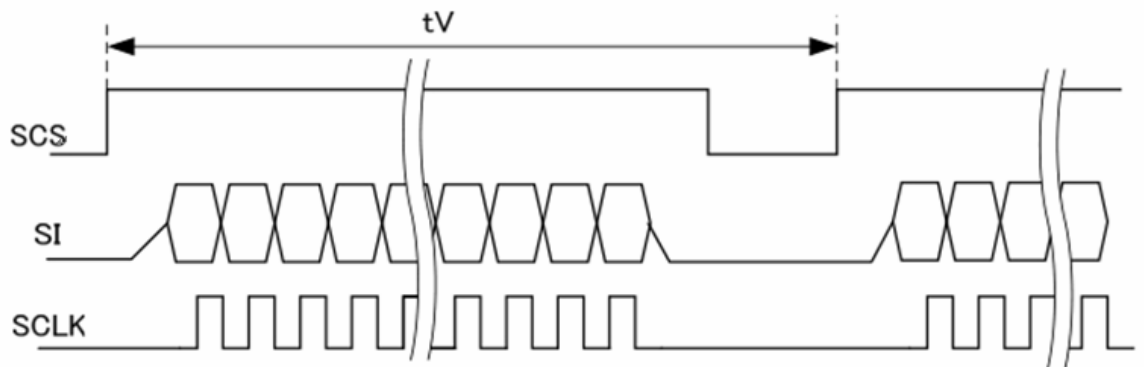

※SCS, SI, SCLK, DISP, EXTCOMIN : 3V input voltage

VDDA=+5.0V、VDD=+5.0V、GND=0V、Ta=25°C

Item	Code	MIN	TYP	MAX	Unit	Remark
Frame Frequency	fSCS	1	1	10	Hz	
Clock Frequency	fSCLK	-	1	2	MHz	
Vertical rush duration	tV	100	-	1000	ms	
COM Frequency	fCOM	0.5	-	5	Hz	

VDDA=+5.0V、VDD=+5.0V、GND=0V、Ta=25°C

Item	Code	MIN	TYP	MAX	Unit	Remark
SCS rising time	trSCS	-	-	50	ns	
SCS falling time	tfSCS	-	-	50	ns	
SCS High width	twSCSH	188	-	-	us	Data update mode
		12	-	-	us	Hold mode
SCS Low width	twSCSL	1	-	-	us	
SCS setup time	tsSCS	3	-	-	us	
SCS hold time	thSCS	1	-	-	us	
SI rising time	trSI	-	-	50	ns	
SI falling time	tfSI	-	-	50	ns	
SI set up time	tsSI	120	-	-	ns	
SI hold time	thSI	190	-	-	ns	
SCLK rising time	trSCLK	-	-	50	ns	
SCLK falling time	tfSCLK	-	-	50	ns	
SCLK High width	twSCLKH	200	450	-	ns	
SCLK Low width	twSCLKL	200	450	-	ns	
EXTCOMIN signal frequency	fEXTCOMIN	1	1	10	Hz	NOTE(1)
EXTCOMIN signal rising time	trEXTCOMIN	-	-	50	ns	
EXTCOMIN signal falling time	tfEXTCOMIN	-	-	50	ns	
EXTCOMIN signal High width	twEXTCOMIN	1	-	-	us	
DISP rising time	trDISP	-	-	50	ns	
DISP falling time	tfDISP	-	-	50	ns	

NOTE(1) : EXTCOMIN frequency should be made lower than frame frequency

11.3 Input Signal Timing Chart

11.3.1 Data Update Mode (1 line)

Updates data of only one specified line (M0="H", M2="L")

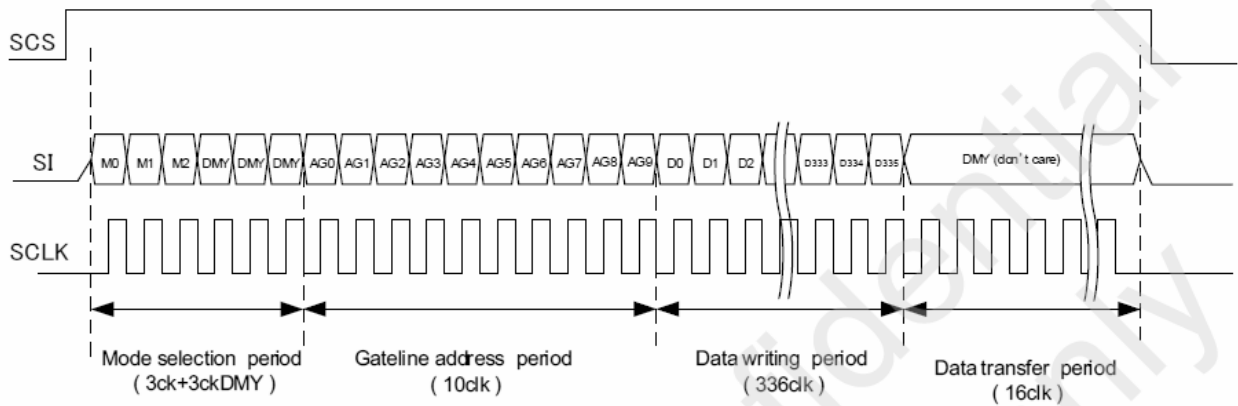

M0: Mode flag. Set for "H". Data update mode (Memory internal data update)

When "L", Hold mode (maintain memory internal data).

M1: Frame inversion flag.

When "H", outputs VCOM="H", and when "L", outputs VCOM="L".

When EXTMODE="H", it can be "H" or "L".

M2: All clear flag.

Refer to 11.3.4) All Clear Mode to execute clear.

DUMMY DATA: Dummy data. It can be "H" or "L" ("L" is recommended.)

D0 - D335 :

Writing Image data (Horizontal Line data)

Hi : (White) Lo : (Black)

※Data write period

Data is being stored in 1st latch block of binary driver on panel.

※Data transfer period

Data written in 1st latch is being transferred (written) to pixel internal memory circuit.

※ For gate line address setting, refer to 11.4) Input Signal and Display.

※ M1: Frame inversion fl is enabled when EXTMODE="L".

※ When SCS becomes "L", M0 and M2 are cleared.

11.3.2 Data Update Mode (Multiple lines)

Updates arbitrary multiple lines data. (M0="H", M2="L")

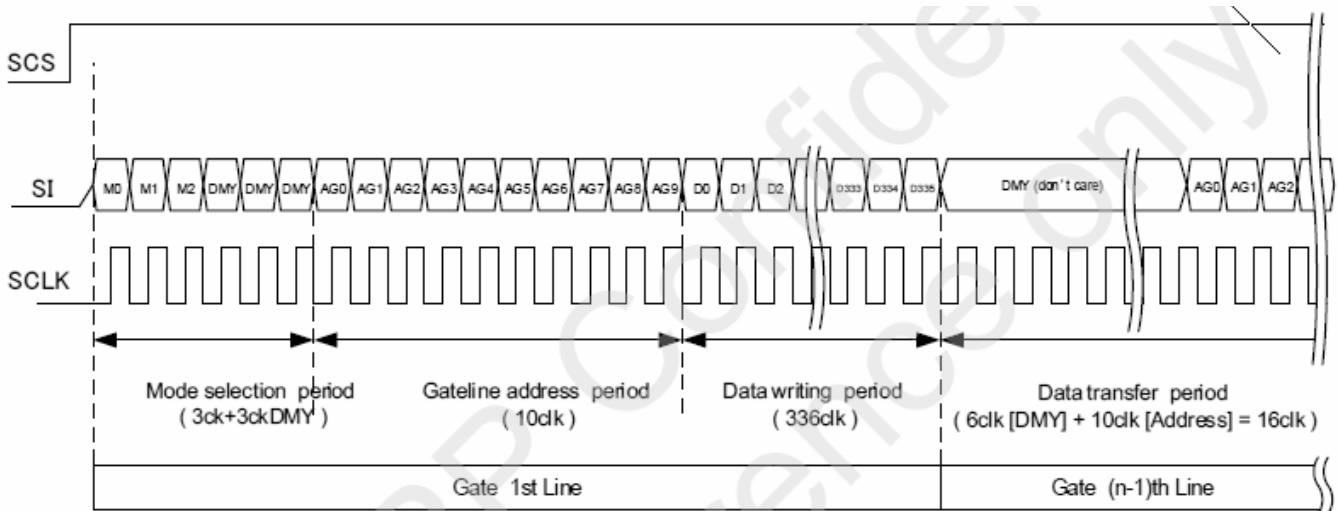
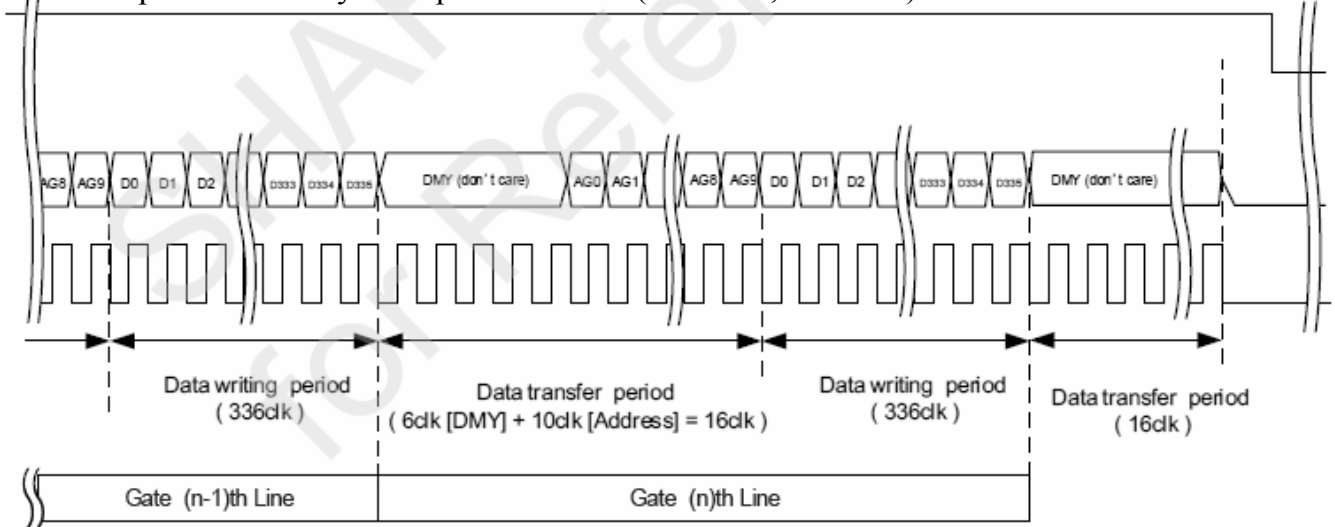

M0: Mode flag. Set for "H". Data update mode (Memory internal data update)

When "L", Hold mode (maintain memory internal data).

M1: Frame inversion flag.

When "H", outputs VCOM="H", and when "L", outputs VCOM="L".

When EXTMODE="H", it can be "H" or "L".

M2: All clear flag.

Refer to 11.3.4) All Clear Mode to execute clear.

DUMMY DATA: Dummy data. It can be "H" or "L" ("L" is recommended.)

D0 - D335 : Writing Image data (Horizontal Line data) Hi : (White) Lo : (Black)

※ Data write period

Data is being stored in 1st latch block of binary driver on panel.

※ Data transfer period

For example, during GL2nd line data transfer period, GL 2nd line address is latched and GL1st line data is transferred from 1st latch to pixel internal memory circuit at the same time.

※ For gate line address setting, refer to 11.4) Input Signal and Display.

※ Input data continuously.

※ M1: Frame inversion flag is enabled when EXTMODE="L".

※ When SCS becomes "L", M0 and M2 are cleared.

11.3.3 Hold Mode

Maintains memory internal data (maintains current display). (M0="L", M2="L")

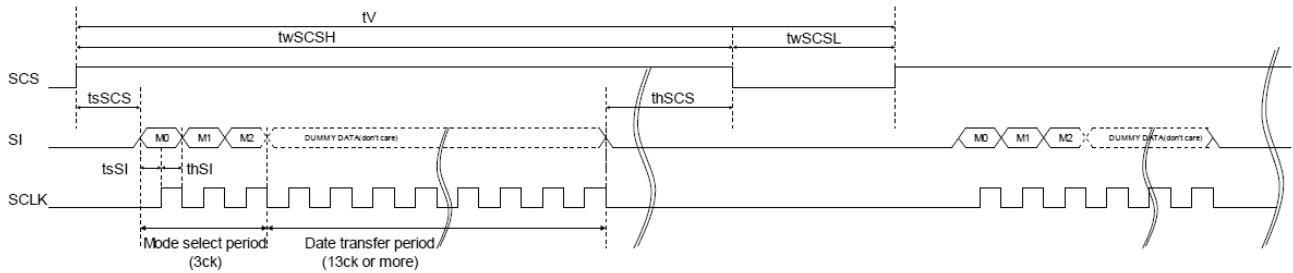

M0: Mode flag. Set for "H". Data update mode (Memory internal data update)

When "L", Hold mode (maintain memory internal data).

M1: Frame inversion flag.

When "H", outputs VCOM="H", and when "L", outputs VCOM="L".

When EXTMODE="H", it can be "H" or "L".

M2: All clear flag.

Refer to 11.3.4) All Clear Mode to execute clear.

DUMMY DATA: Dummy data. It can be "H" or "L" ("L" is recommended.)

※ M1: Frame inversion flag is enabled when EXTMODE="L"

※ When SCS becomes "L", M0 and M2 are cleared.

11.3.4 All Clear Mode

Clears memory internal data and writes white. (M0="L", M2="H")

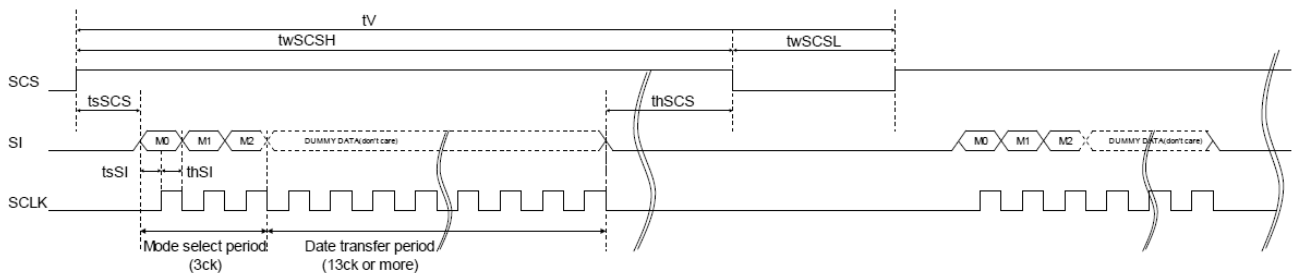

M0: Mode flag.

Set it "L".

M1: Frame inversion flag.

When "H", outputs VCOM="H", and when "L", outputs VCOM="L".

When EXTMODE="H", it can be "H" or "L".

M2: All clear flag.

Set it "H"

DUMMY DATA: Dummy data. It can be "H" or "L" ("L" is recommended.)

※ M1: Frame inversion flag is enabled when EXTMODE="L".

※ When SCS becomes "L", M0 and M2 are cleared.

11.3.5 COM Inversion

There are two types of inputs, COM signal serial input (EXTMODE="L") and External COM signal input (EXTMODE="H").

EXTMODE="L"

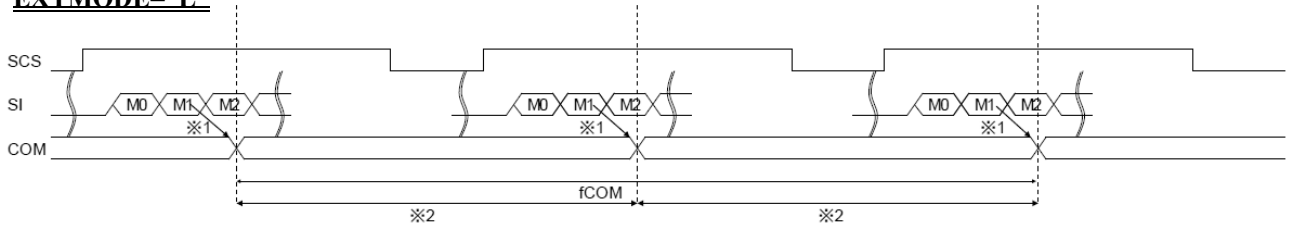

M1 : COM polarity inversion flag: If M1 is "H" then VCOM="H" is output. If M1 is "L" then VCOM="L" is output.

※ 1 : COM inversion has been changed by M1 flag statement.

※ 2 : The periods of plus polarity and minus polarity should be same length as much as possible.

EXTMODE="H"

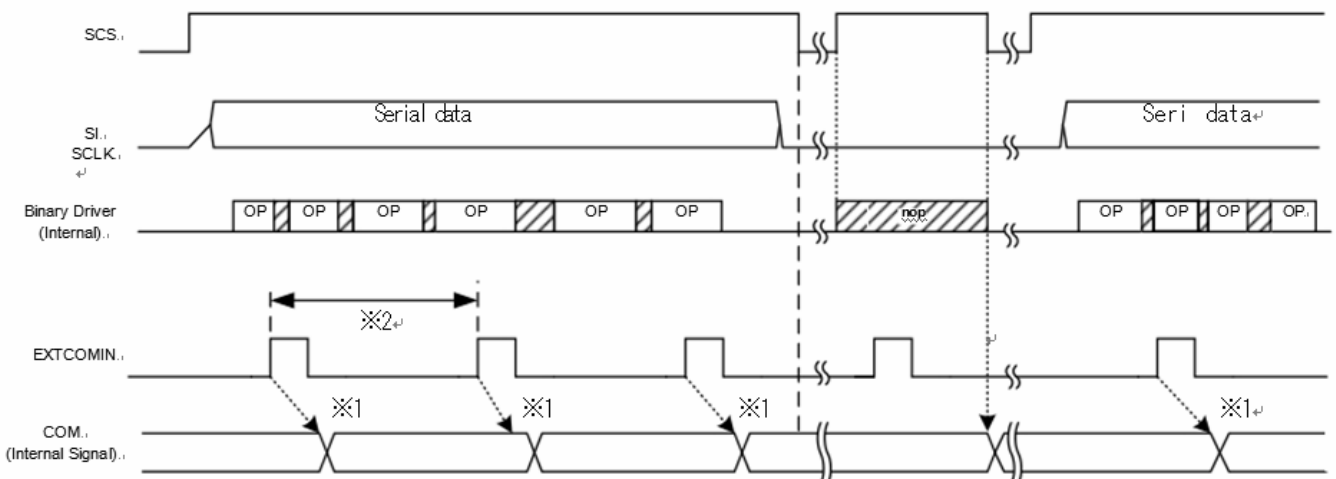

※ 1 : Make "COM" reversal depending.

※ 2 : The period of EXTCOMIN should be constant and the period of COM inversion should be constant depending on EXTCOMIN.(with Send a serial data or making the period of "SCS=Lo")

※EXTCOMIN input when the SCS signals is low.

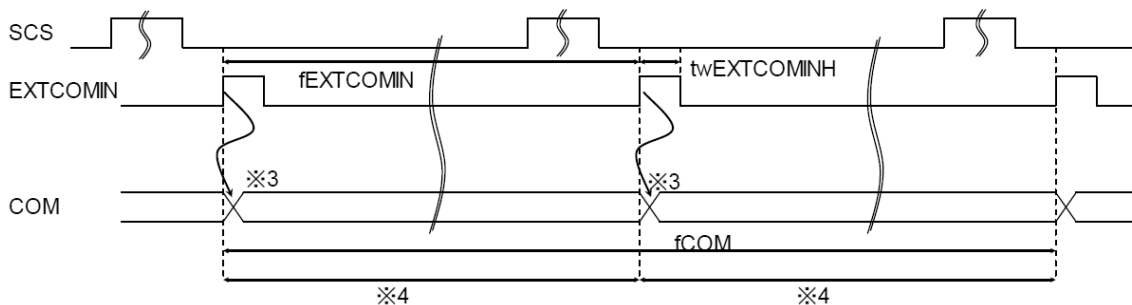

※ 3 : LC inversion polarity has been set by the rising edge of EXTCOMIN.

※ 4 : The period of EXTCOMIN should be constant.

11.4 Input Signal and Screen Display, Gate Address (Line) Setup

Data screen display position [H,V]

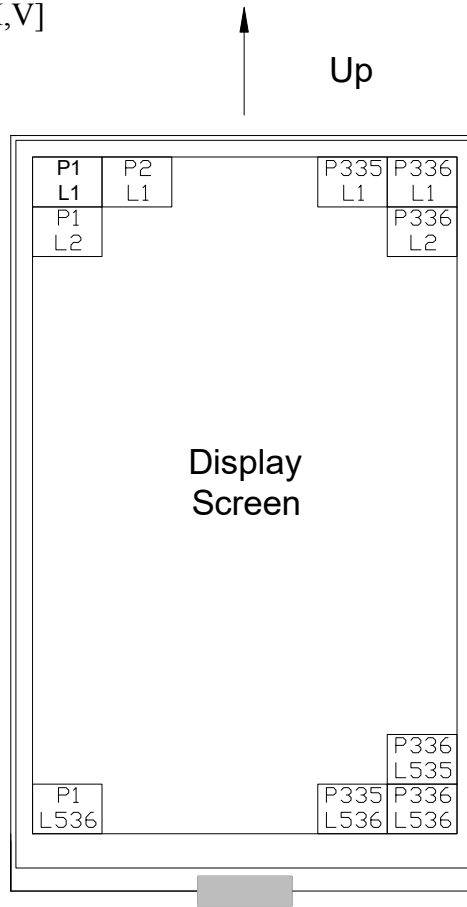

Line	Gate Line Address Setup									
	AG0	AG1	AG2	AG3	AG4	AG5	AG6	AG7	AG8	AG9
L1	H	L	L	L	L	L	L	L	L	L
L2	L	H	L	L	L	L	L	L	L	L
L3	H	H	L	L	L	L	L	L	L	L
.
.
.
L534	L	H	H	L	H	L	L	L	L	H
L535	H	H	H	L	H	L	L	L	L	H
L536	L	L	L	H	H	L	L	L	L	H

12. General Precautions

Please pay attentions to the followings as using the LCD module.

12.1 Handling

- (a) Do not apply strong mechanical stress like drop, shock or any force to LCD module. It may cause improper operation, even damage.
- (b) Because the polarizer is very fragile and easy to be damaged, do not hit, press or rub the display surface with hard materials.
- (c) Do not put heavy or hard material on the display surface, and do not stack LCD modules.
- (d) If the display surface is dirty, please wipe the surface softly with cotton swab or clean cloth.
- (e) Avoid using Ketone type materials (e.g. Acetone), Toluene, Ethyl acid or Methyl chloride to clean the display surface. It might damage the polarizer permanently. The recommended solvents are water and Isopropyl alcohol.

- (f) Wipe off water droplets or oil immediately.
- (g) Protect the LCD module from ESD. It will damage the LSI and the electronic circuit.
- (h) Do not touch the output pins directly with bare hands.
- (I) Do not disassemble the LCD module.

12.2 Storage

- (a) Do not leave the LCD modules in high temperature, especially in high humidity for a long time.
- (b) Do not expose the LCD modules to sunlight directly.
- (c) The liquid crystal is deteriorated by ultraviolet. Do not leave it in strong ultraviolet ray for a long time.
- (d) Avoid condensation of water. It may cause improper operation.
- (e) Please stack only up to the number stated on carton box for storage and transportation. Excessive weight will cause deformation and damage of carton box.

12.3 Operation

- (a) When mounting or dismantling the LCD modules, turn the power off.
- (b) Protect the LCD modules from electric shock.
- (c) The Driver IC control algorithms should always be obeyed to avoid damaging the LSI and electronic circuit.
- (d) Be careful to avoid mixing up the polarity of power supply for backlight.
- (e) Absolute maximum rating specified above has to be always kept in any case. Exceeding it may cause non-recoverable damage of electronic components or, nevertheless, burning.
- (f) When a static image is displayed for a long time, remnant image is likely to occur.
- (g) Be sure to avoid bending the FPC to an acute shape, it might break FPC.

12.4 Others

- (a) If the liquid crystal leaks from the panel, it should be kept away from the eyes or mouth.
- (b) For the fragility of polarizer, it is recommended to attach a transparent protective plate over the display surface.
- (c) It is recommended to peel off the protection film on the polarizer slowly so that the electrostatic charge can be minimized.

13. Quality and reliability

13-1 Test condition

Test should be conducted under the following conditions:

- Ambient temperature : $25 \pm 5^{\circ}\text{C}$
- Humidity : $55 \pm 10\% \text{ RH}$

13-2 Sampling plan

Sampling method shall be in accordance with MIL-STD-105D, inspection level II, normal inspection, and single sampling plan tables for normal tightened and reduced inspection.

13-3 Acceptable quality level

A major defect is a defect that could result in failure or materially reduce that the usability of the unit of product for its intended purpose.

A minor defect is one that does not materially reduce the usability of the unit of product for its intended purpose or is a departure from established standards having no significant bearing on the effective use or operation of the unit.

13-4 Appearance

1. Appearance test is to be conducted by human eyes at approximately 30cm distance from LCD module under the single fluorescent light without reflection.

- Condition:
- a. Illumination: 500 Lux min
 - b. Inspect determination: 30cm
 - c. Inspect direction: above the LCM
 - d. View angle: $\pm 30^{\circ}$

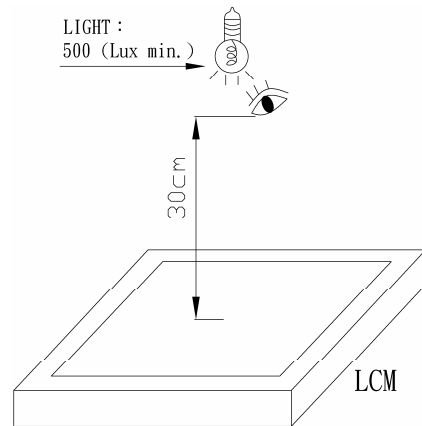

The inspection area of LCD panel shall be within the range of following limits.

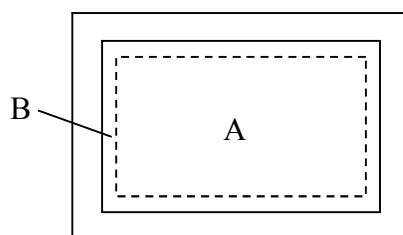

Zone A : Display Active Area

Zone B : Viewing Area

Inspection quality criteria for TFT LCM

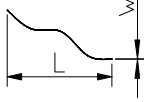
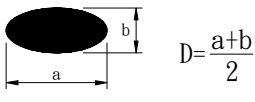
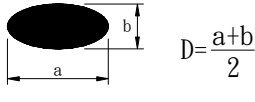
ITEM	DESCRIPTION OF DEFECTS	Zone	Acceptable level (%)																					
DIMENSION	Refer to individual acceptance specification	A,B	2.5																					
LINE DEFECT ON SURFACE (SCRATCHES, BLACK/ WHITE LINE)	(a) $W \leq 0.05\text{mm}$, disregard (b) $L \leq 15\text{mm}$ & $0.05\text{mm} < W \leq 0.1\text{mm}$, $N \leq 1$ (c) $W > 0.1\text{mm}$, REJ 	A,B	2.5																					
SPOT DEFECT ON SURFACE (BLACK/ WHITE SPOT)	Average diameter, D (a) $D \leq 0.15\text{mm}$, $N \leq 3$.ACC (b) $0.15\text{mm} < D \leq 0.3\text{mm}$, $N \leq 2$.ACC (c) $D > 0.3\text{mm}$, REJ (d) Distance between 2 spots $\geq 5\text{mm}$ 	A,B	2.5																					
PROTRUDE DOT/ DENT ON SURFACE	Average diameter D (a) $D \leq 0.15\text{mm}$, $N \leq 3$.ACC (b) $0.15\text{mm} < D \leq 0.3\text{mm}$, $N \leq 2$.ACC (c) $D > 0.3\text{mm}$, REJ 	A,B	2.5																					
BRIGHT/ DARK POINT	<table border="1" style="width: 100%; border-collapse: collapse;"> <thead> <tr> <th colspan="2">Item</th> <th>Allow number in Area A</th> </tr> </thead> <tbody> <tr> <td rowspan="4" style="text-align: center;">(a) Bright point</td> <td>Single point</td> <td style="text-align: center;">0</td> </tr> <tr> <td>Two adjacent point</td> <td style="text-align: center;">0</td> </tr> <tr> <td>Three adjacent point</td> <td style="text-align: center;">0</td> </tr> <tr> <td>Total point</td> <td style="text-align: center;">0</td> </tr> <tr> <td rowspan="4" style="text-align: center;">(b) Dark point</td> <td>Single point</td> <td style="text-align: center;">0</td> </tr> <tr> <td>Two adjacent point</td> <td style="text-align: center;">0</td> </tr> <tr> <td>Three adjacent point</td> <td style="text-align: center;">0</td> </tr> <tr> <td>Total point</td> <td style="text-align: center;">0</td> </tr> </tbody> </table>	Item		Allow number in Area A	(a) Bright point	Single point	0	Two adjacent point	0	Three adjacent point	0	Total point	0	(b) Dark point	Single point	0	Two adjacent point	0	Three adjacent point	0	Total point	0	A	2.5
Item		Allow number in Area A																						
(a) Bright point	Single point	0																						
	Two adjacent point	0																						
	Three adjacent point	0																						
	Total point	0																						
(b) Dark point	Single point	0																						
	Two adjacent point	0																						
	Three adjacent point	0																						
	Total point	0																						
CHROMA MURA	Mura and leak are defined through transmission ND 5% filter	A	2.5																					
DISPLAY ABNORMAL	(a) Non display (b) Line defect (c) Response time, contrast ratio, brightness or viewing angle abnormal (d) Water ripple (e) Flicker	A	0.65																					

NOTE : (1) ACC : Accept (2) REJ : Reject

13-5 Reliability Test Items

No.	Test items	Conditions	Remark
1	High temperature operation	70°C , 96hours	--
2	Low temperature operation	-20°C , 96hours	--
3	High temperature storage	80°C , 96hours	--
4	Low temperature storage	-30°C , 96hours	--
5	High temperature & high humidity operation	40°C , 90% RH , 96hours	--
6	Thermal Shock storage	-30°C , 30min. ~ 80°C , 30min. , 5 Cycles	--
7	Vibration test	10~150 Hz, 100m/s ² , 120min	Non-operation
<p>Criterion: There should be no change which might affect the practical display function when the display quality test is conducted under normal operating condition..</p>			