



## ASI-T-210R48A4AN/D

Item	Contents	Unit
Size	2.1	inch
Resolution	480(RGB) x 480	/
Interface	RGB	/
Technology type	IPS TFT	/
Pixel Configuration	R.G.B. Stripe	
Pixel Pitch	0.111 x 0.111	
Outline Dimension (W x H x D)	58.18 x 60.71 x 2.26	mm
Active Area	53.28 x 53.28	mm
Backlight Type	LED	/
Display Controller/ driver	ST7701SN	/
Viewing Direction	ALL	



## Record of Revision

Date	Revision No.	Summary
2024-05-20	1.0	Rev 1.0 was issued

## 1. Scope

This data sheet is to introduce the specification of ASI-T-210R48A4AN/D, active matrix TFT module. It is composed of a color TFT-LCD panel, driver ICs, FPC and a backlight unit. The 2.1" display area contains 480(RGB) x 480 pixels.

As to basic specification of the driver IC, refer to the IC specification and datasheet.

## 2. Application

Digital equipments which need color display, mobile navigator/video systems.

## 3. General Information

Item	Contents	Unit
Size	2.1	inch
Resolution	480(RGB) x 480	/
Interface	RGB	/
Technology type	IPS TFT	/
Pixel Configuration	R.G.B. Stripe	
Pixel Pitch	0.111 x 0.111	
Outline Dimension (W x H x D)	58.18 x 60.71 x 2.26	mm
Active Area	53.28 x 53.28	mm
Backlight Type	LED	/
Display Controller/ driver	ST7701SN	/
Viewing Direction	ALL	

### 4. Outline Drawing

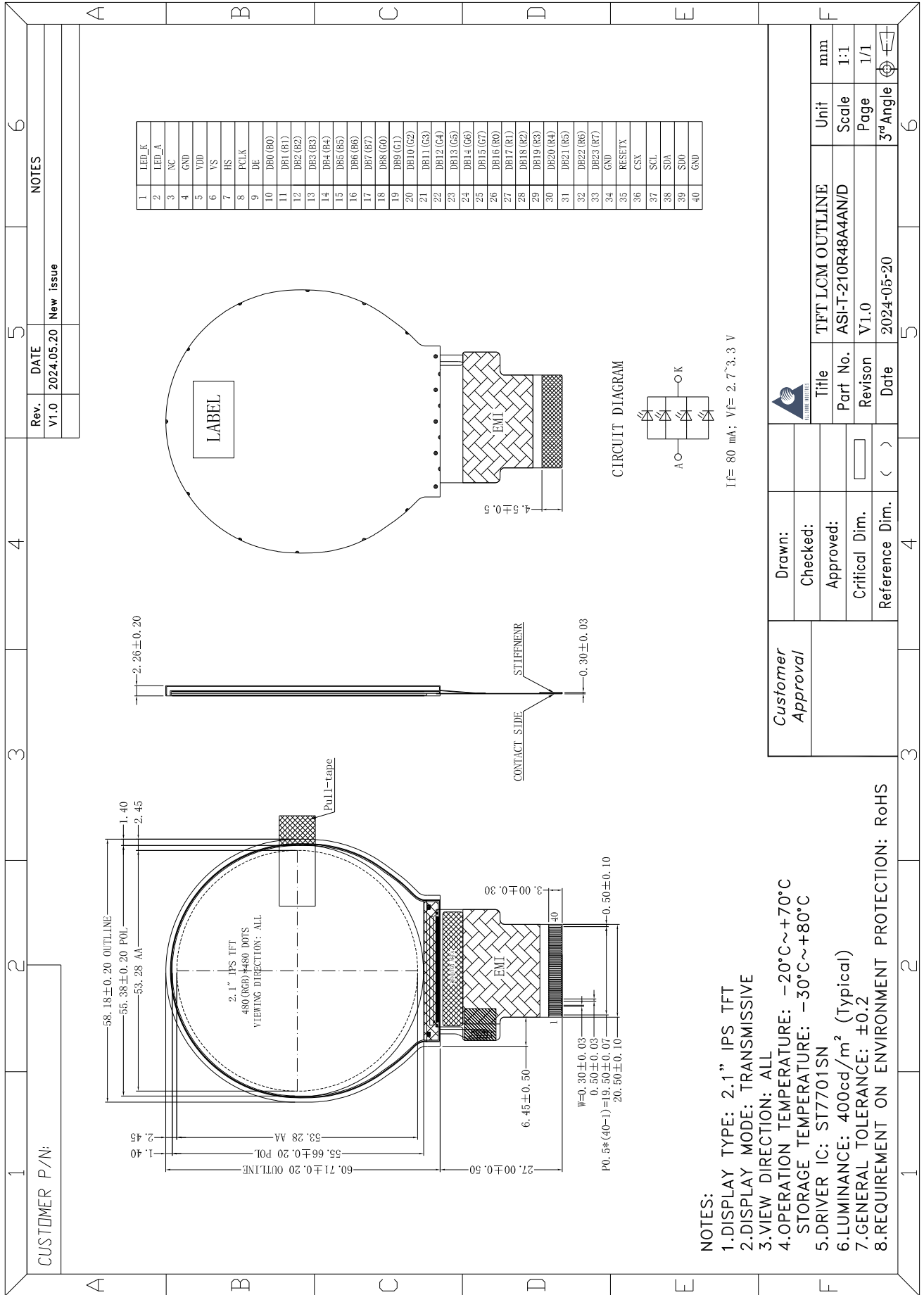

## 5. Interface signals

No	Symbol	Description	Remark
1	LED_K	LED Backlight (Cathode)	
2	LED_A	LED Backlight (Anode)	
3	NC	No connection	
4	GND	Ground	
5	VDD	Power supply	
6	VS	Frame synchronizing signal for RGB interface operation	
7	HS	Line synchronizing signal for RGB interface operation	
8	PCLK	Clock for input data	
9	DE	Data enable	
10	DB0(B0)	Data bus input (Blue)	
11	DB1(B1)	Data bus input (Blue)	
12	DB2(B2)	Data bus input (Blue)	
13	DB3(B3)	Data bus input (Blue)	
14	DB4(B4)	Data bus input (Blue)	
15	DB5(B5)	Data bus input (Blue)	
16	DB6(B6)	Data bus input (Blue)	
17	DB7(B7)	Data bus input (Blue)	
18	DB8(G0)	Data bus input (Green)	
19	DB9(G1)	Data bus input (Green)	
20	DB10(G2)	Data bus input (Green)	
21	DB11(G3)	Data bus input (Green)	
22	DB12(G4)	Data bus input (Green)	
23	DB13(G5)	Data bus input (Green)	
24	DB14(G6)	Data bus input (Green)	
25	DB15(G7)	Data bus input (Green)	
26	DB16(R0)	Data bus input (Red)	
27	DB17(R1)	Data bus input (Red)	
28	DB18(R2)	Data bus input (Red)	
29	DB19(R3)	Data bus input (Red)	
30	DB20(R4)	Data bus input (Red)	
31	DB21(R5)	Data bus input (Red)	
32	DB22(R6)	Data bus input (Red)	

33	DB23(R7)	Data bus input (Red)	
34	GND	Ground	
35	RESETX	Reset pin, active "L".	
36	CSX	Chip select signal, active "L"	
37	SCL	Serial clock input for SPI interface	
38	SDA	Serial data input pin for SPI interface	
39	SDO	Serial data output pin for SPI interface	
40	GND	Ground	

## 6. Absolute maximum Ratings

### 6.1. Electrical Absolute max. ratings

Parameter	Symbol	MIN	MAX	Unit	Remark
Power Supply Voltage	VDD	-0.3	4.6	V	
	VDDI	-0.3	4.6	V	

### 6.2. Environment Conditions

Item	Symbol	MIN	MAX	Unit	Remark
Operating Temperature	TOPR	-20	70	°C	
Storage Temperature	TSTG	-30	80	°C	

Note: If the absolute maximum rating of even is one of the above parameters is exceeded even momentarily, the quality of the product may be degraded. Absolute maximum ratings, therefore, specify the values exceeding which the product may be physically damaged. Be sure to use the product within the range of the absolute maximum ratings.

## 7. Electrical Specifications

### 7.1 Electrical characteristics

GND=0V, Ta=25°C

Item	Symbol	MIN	TYP	MAX	Unit	Remark
Power Supply Voltage	VDD	2.5	3.3	3.6	V	
	VDDI	1.65	1.8	3.3	V	
Input voltage	H	V <sub>IH</sub>	0.7*VDDI	-	VDDI	V
	L	V <sub>IL</sub>	GND	-	0.3*VDDI	V

### 7.2 LED Backlight

Ta=25°C

Item	Symbol	MIN	TYP	MAX	Unit	Remark
Forward Current	I <sub>L</sub>	-	80	-	mA	
Forward Voltage	V <sub>L</sub>	2.7	3.0	3.3	V	Note1
LED life time	-	-	50,000	-	Hrs	Note2

#### Notes:

1. The LED Supply Voltage is defined by the number of LED at Ta=25°C and I<sub>L</sub> =80mA.
2. The “LED life time” is defined as the module brightness decrease to 50% original brightness at Ta=25°C and I<sub>L</sub> =80mA. The LED lifetime could be decreased if operating I<sub>L</sub> is larger than 80mA.
3. LED Backlight Circuit Diagram as follow:

#### CIRCUIT DIAGRAM

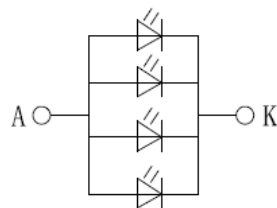

$$I_f = 80 \text{ mA}; V_f = 2.7 \sim 3.3 \text{ V}$$

## 8. Command/AC Timing

### 8.1 Serial Interface Characteristics (3-line serial)

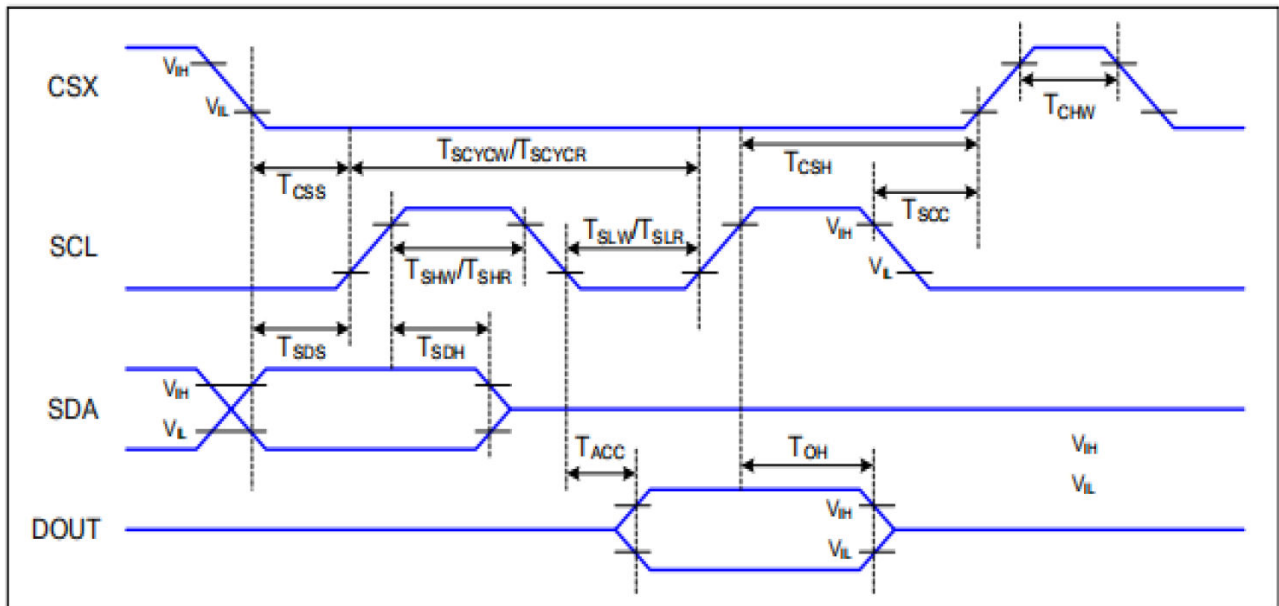

Signal	Symbol	Parameter	Min.	Max.	Unit	Description
CSX	tcss	Chip select setup time (write)	15	-	ns	
	tcsH	Chip select hold time (write)	15	-	ns	
	tcss	Chip select setup time (read)	60	-	ns	
	tscC	Chip select hold time (read)	60	-	ns	
	tchW	Chip select "H" pulse width	40	-	ns	
SCL	tscYCW	Serial clock cycle (write)	66	-	ns	
	tshW	SCL "H" pulse width (write)	15	-	ns	
	tsLW	SCL "L" pulse width (write)	15	-	ns	
	tscYCR	Serial clock cycle (read)	150	-	ns	
	tshR	SCL "H" pulse width (read)	60	-	ns	
	tsLR	SCL "L" pulse width (read)	60	-	ns	
SDA (DIN)	tsDS	Data setup time	10	-	ns	
	tsDH	Data hold time	10	-	ns	

### 8.2 RGB Interface Characteristics

Signal	Symbol	Parameter	Min.	Max.	Unit	Description
HSYNC VSYNC	tsYNCS	VSYNC, HSYNC setup time	30	-	ns	
ENABLE	tENS	Enable setup time	25	-	ns	
	tENH	Enable hold time	25	-	ns	
DOTCLK	PWDH	DOTCLK high-level pulse width	60	-	ns	
	PWDL	DOTCLK low-level pulse width	60	-	ns	
	tcYCD	DOTCLK cycle time	120	-	ns	



	trghr, trghf	DOTCLK rise/fall time	-	20	ns	
DB	tpDS	PD data setup time	50	-	ns	
	tpDH	PD data hold time	50	-	ns	

Table: 18/16 bits RGB interface timing characteristics

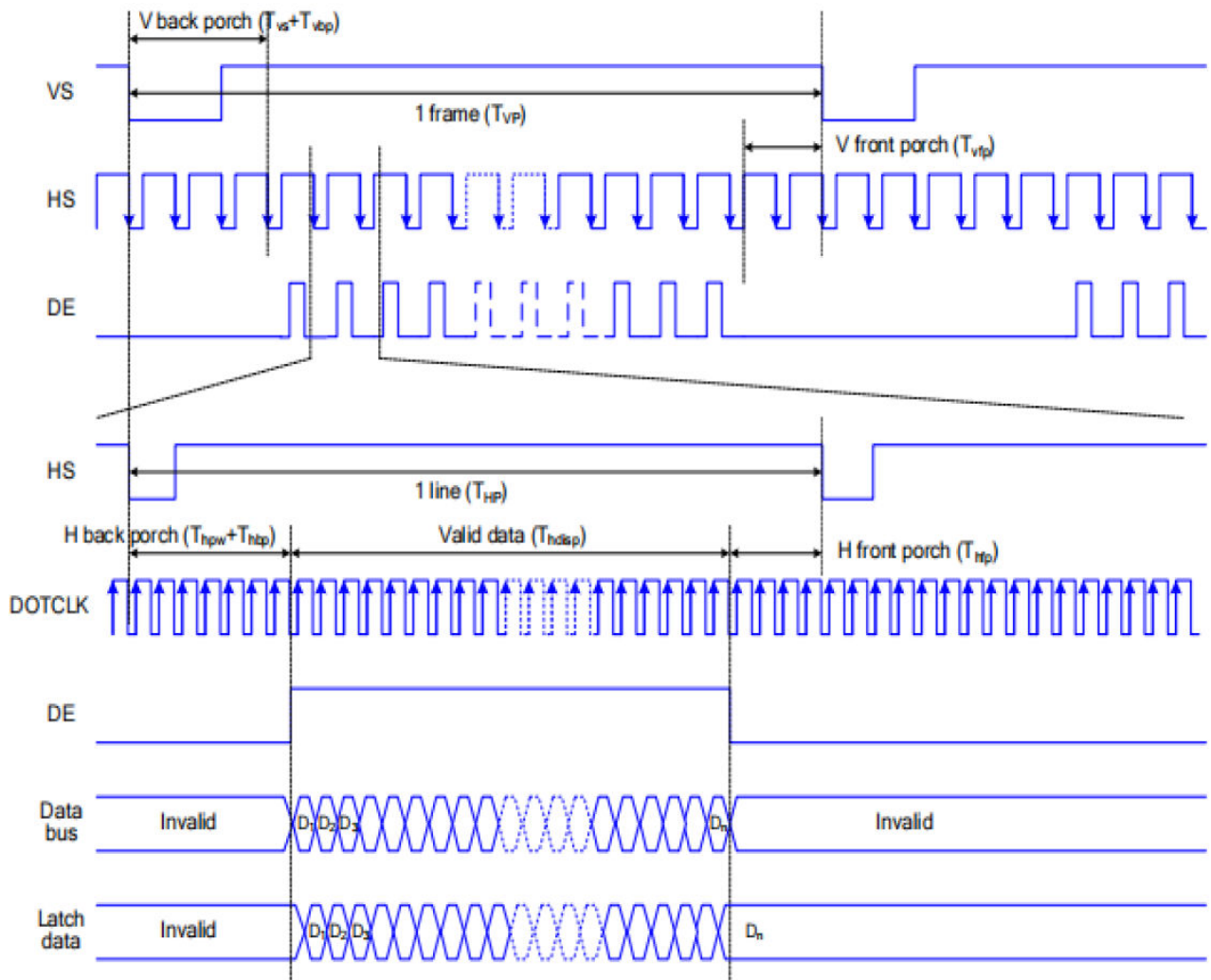
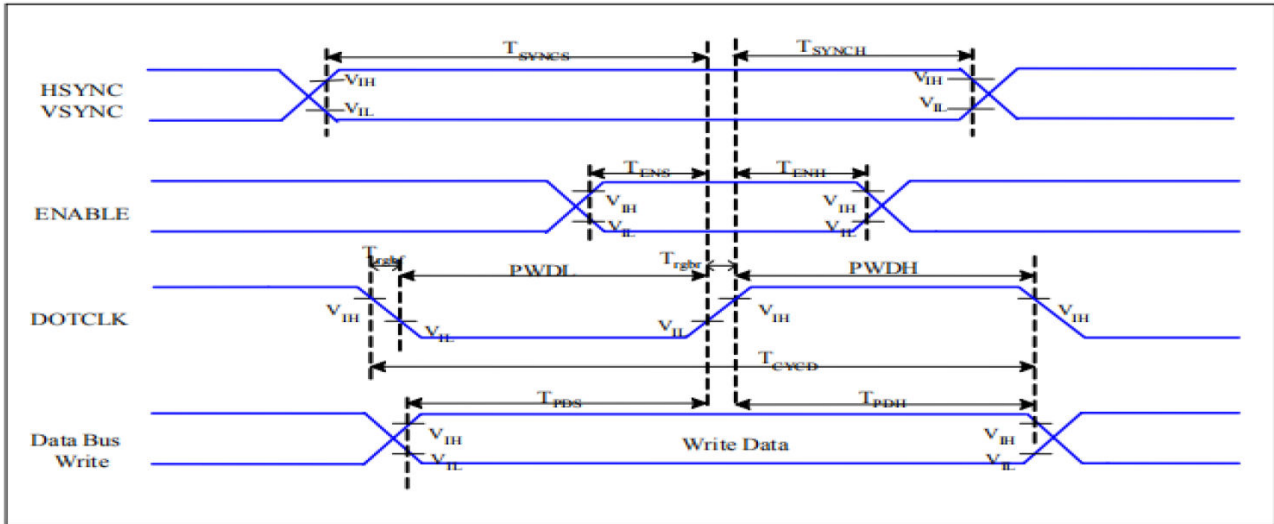

Note: The setting of front porch and back porch in host must match that in IC as this mode.

## 9. Optical Specification

Ta=25°C

Item	Symbol	Condition	Min	Typ.	Max.	Unit	Remark
Contrast Ratio	CR	$\theta=0^\circ$	800	1000	-		Note1 Note2
Response Time	Tr+Tf	25°C	-	30	35	ms	Note1 Note3
View Angles	$\Theta T$	CR $\geq 10$	80	85	-	Degree	Note 4
	$\Theta B$		80	85	-		
	$\Theta L$		80	85	-		
	$\Theta R$		80	85	-		
Chromaticity	White	Brightness is on	Typ-0.05	(0.300)	Typ+0.05		Note5, Note1
				y			
	Red			x			
				y			
	Green			x			
				y			
	Blue			x			
				y			
Luminance	L		-	400	-	cd/m <sup>2</sup>	Note1 Note6
Uniformity	U		75	80	-	%	Note1 Note7

Note 1: Definition of optical measurement system.

Temperature = 25°C(±3°C)

LED back-light: ON, Environment brightness < 150 lx

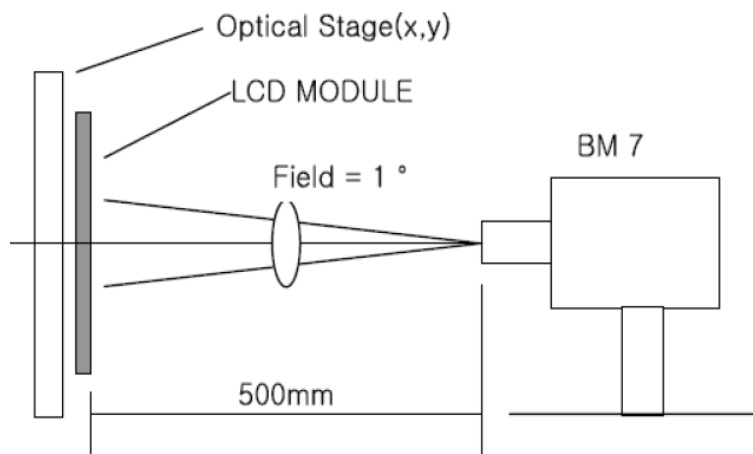

Note 2: Contrast ratio is defined as follow:

$$\text{Contrast Ratio} = \frac{\text{Surface Luminance with all white pixels}}{\text{Surface Luminance with all black pixels}}$$

Note 3: Response time is defined as follow:

Response time is the time required for the display to transition from black to white (Rise Time,  $T_r$ ) and from white to black(Decay Time,  $T_f$ ).

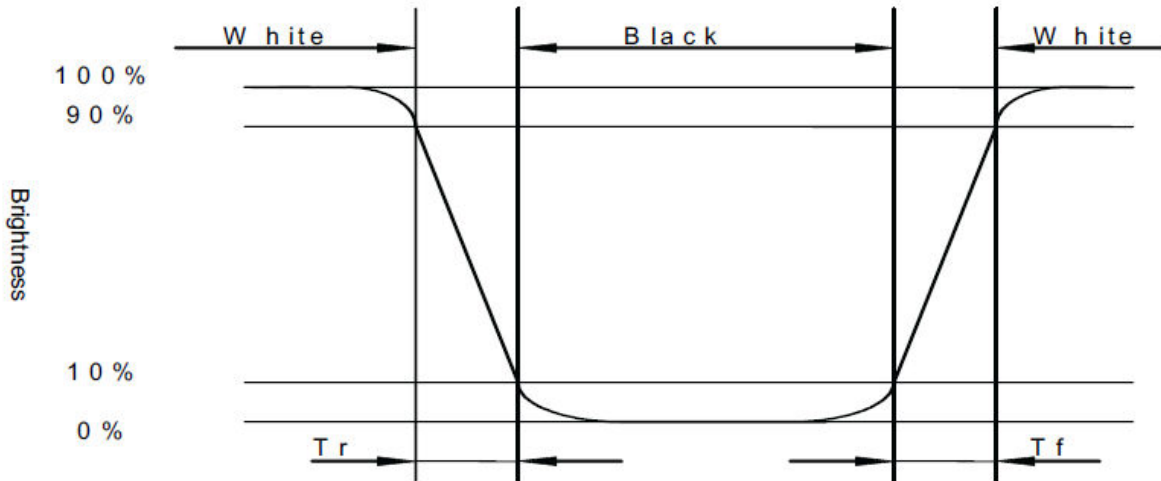

Note 4: Viewing angle range is defined as follow:

Viewing angle is measured at the center point of the LCD.

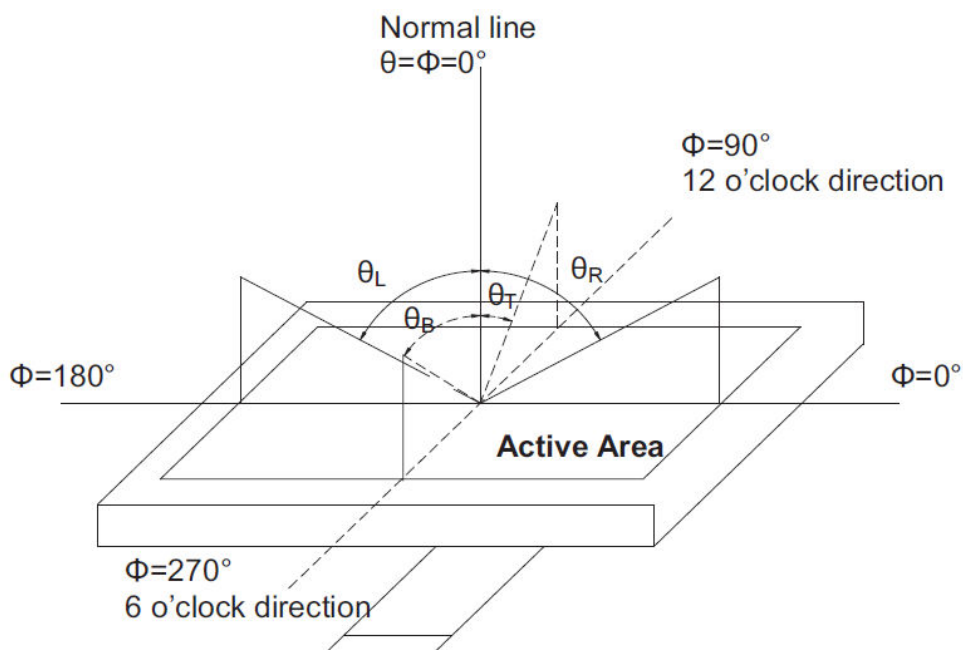

Note 5: Color chromaticity is defined as follow: (CIE1931)

Color coordinates measured at center point of LCD.

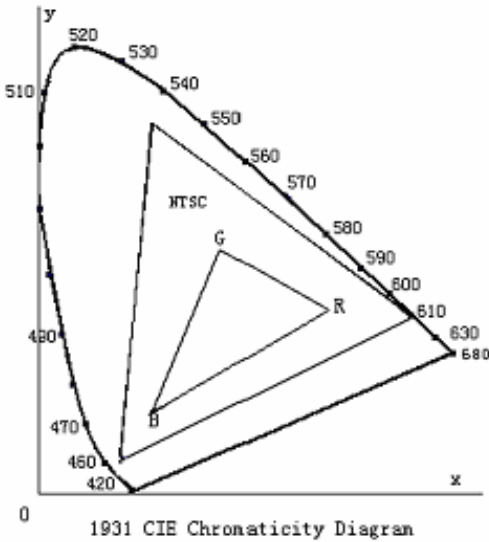

$$S = \frac{\text{area of RGB triangle}}{\text{area of NTSC triangle}} \times 100\%$$

Note 6: Luminance is defined as follow:

Luminance is defined as the brightness of all pixels "White" at the center of display area on optimum contrast.

Note 7: Luminance Uniformity is defined as follow:

$$\Delta Bp = Bp (\text{Min.}) / Bp (\text{Max.}) \times 100 (\%)$$

Bp (Max.) = Maximum brightness in 5 measured spots

Bp (Min.) = Minimum brightness in 5 measured spots.

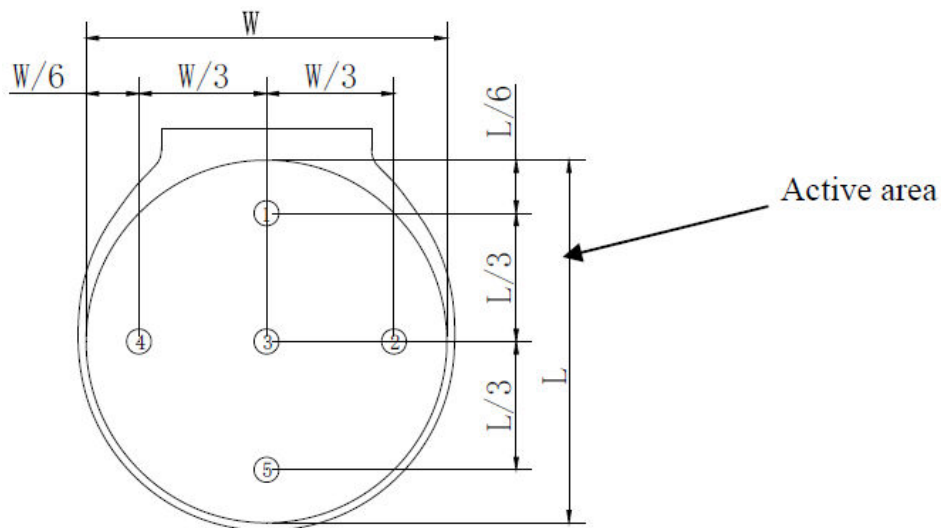

## 10. Environmental / Reliability Tests

No	Test Item	Condition	Judgment criteria
1	High Temp Operation	Ta= +70°C, 96hrs	Per table in below
2	Low Temp Operation	Ta= -20°C, 96hrs	Per table in below
3	High Temp Storage	Ta= +80°C, 96hrs	Per table in below
4	Low Temp Storage	Ta= -30°C, 96hrs	Per table in below
5	High Temp & High Humidity Storage	Ta= +40°C, 90% RH, 96 hours	Per table in below (polarizer discoloration is excluded)
6	Thermal Shock (Non-operation)	-30°C 30 min~+80°C 30 min, Change time:5min, 5Cycles	Per table in below
7	ESD (Operation)	Air discharge:+/-8KV, Contact discharge:4KV	Per table in below
8	Vibration (Non-operation)	10Hz~150Hz, 100m/s <sup>2</sup> , 120min	Per table in below
9	Shock (Non-operation)	Half- sine wave,300m/s <sup>2</sup> ,11ms	Per table in below
10	Package Drop Test	Height:80 cm, 1 corner, 3 edges, 6 surfaces	Per table in below

INSPECTION	CRITERION(after test)
Appearance	No Crack on the FPC, on the LCD Panel
Alignment of LCD Panel	No Bubbles in the LCD Panel No other Defects of Alignment in Active area
Electrical current	Within device specifications
Function / Display	No Broken Circuit, No Short Circuit or No Black line No Other Defects of Display

## 11. Precautions for Use of LCD Modules

### 11.1 Safety

The liquid crystal in the LCD is poisonous. Do not put it in your mouth. If the liquid crystal touches your skin or clothes, wash it off immediately using soap and water.

### 11.2 Handling

- A. The LCD and touch panel is made of plate glass. Do not subject the panel to mechanical shock or to excessive force on its surface.
- B. Do not handle the product by holding the flexible pattern portion in order to assure the reliability
- C. Transparency is an important factor for the touch panel. Please wear clear finger sacks, gloves and mask to protect the touch panel from finger print or stain and also hold the portion outside the view area when handling the touch panel.
- D. Provide a space so that the panel does not come into contact with other components.
- E. To protect the product from external force, put a covering lens (acrylic board or similar board) and keep an appropriate gap between them.
- F. Transparent electrodes may be disconnected if the panel is used under environmental conditions where dew condensation occurs.
- G. Property of semiconductor devices may be affected when they are exposed to light, possibly resulting in IC malfunctions.
- H. To prevent such IC malfunctions, your design and mounting layout shall be done in the way that the IC is not exposed to light in actual use.

### 11.3 Static Electricity

- A. Ground soldering iron tips, tools and testers when they are in operation.
- B. Ground your body when handling the products.
- C. Power on the LCD module before applying the voltage to the input terminals.
- D. Do not apply voltage which exceeds the absolute maximum rating.
- E. Store the products in an anti-electrostatic bag or container.

### 11.4 Storage

- A. Store the products in a dark place at  $+25^{\circ}\text{C} \pm 10^{\circ}\text{C}$  with low humidity (40% RH to 60% RH). Don't expose to sunlight or fluorescent light.
- B. Storage in a clean environment, free from dust, active gas, and solvent.

### 11.5 Cleaning

- A. Do not wipe the touch panel with dry cloth, as it may cause scratch.
- B. Wipe off the stain on the product by using soft cloth moistened with ethanol. Do not allow ethanol to get in between the upper film and the bottom glass. It may cause peeling issue or defective operation. Do not use any organic solvent or detergent other than ethanol.

### 11.6 Cautions for installing and assembling

- A. Bezel edge must be positioned in the area between the Active area and View area. The bezel may press the touch screen and cause activation if the edge touches the active area. A gap of approximately 0.5mm is needed between the bezel and the top electrode. It may cause unexpected activation if the gap is too narrow. There is a tolerance of 0.2 to 0.3mm for the outside dimensions of the touch panel and tail. A gap must be made to absorb the tolerance in the case and connector.
- B. In order to make the display assembly stable and firm, ASI recommends to design some supporting at the display backside, especially for the display with tape-attached touch panel, such supporting is important and essential, or else, the display may drop-off from front after some period of time.
- C. Do not display the fixed pattern for a long time because it may develop image sticking due to the LCD structure. If the screen is displayed with fixed pattern, use a screen saver.

