



ASI-T-1040GA6TN/D

Item	Contents	Unit
Size	10.4	inch
Resolution	640x (RGB) x 480	/
Interface	TTL	/
Technology type	a-Si TFT	/
Pixel pitch	0.33x0.33	mm
Pixel Configuration	R.G.B. Vertical Stripe	
Outline Dimension (W x H x D)	225.5X176.3X7.81	mm
Active Area	211.2X158.4	mm
Display Mode	Transmissive, Normally black	/
Backlight Type	LED	/

Record of Revision

Date	Revision No.	Summary
2011-9-15	1.0	Rev 1.0 was issued
2014-07-30	1.1	Change the temperature range

ASI-T-1040GA6TN/D

1. Scope

This data sheet is to introduce the specification of ASI-T-1040GA6TN/D active matrix true TFT module. It is composed of a 10.4" TFT LCD panel, driver ICs, driving board and a backlight unit. The 10.4 display area contains 640(RGB) x 480 pixels.

2. Application

Digital equipments which need color display, monitor, POS, video systems for industrial applications and portable applications.

3. General Information

Item	Contents	Unit
Size	10.4	inch
Resolution	640x (RGB) x 480	/
Interface	TTL	/
Technology type	a-Si TFT	/
Pixel pitch	0.33x0.33	mm
Pixel Configuration	R.G.B. Vertical Stripe	
Outline Dimension (W x H x D)	225.5X176.3X7.81	mm
Active Area	211.2X158.4	mm
Display Mode	Transmissive, Normally black	/
Backlight Type	LED	/

4. Outline Drawing

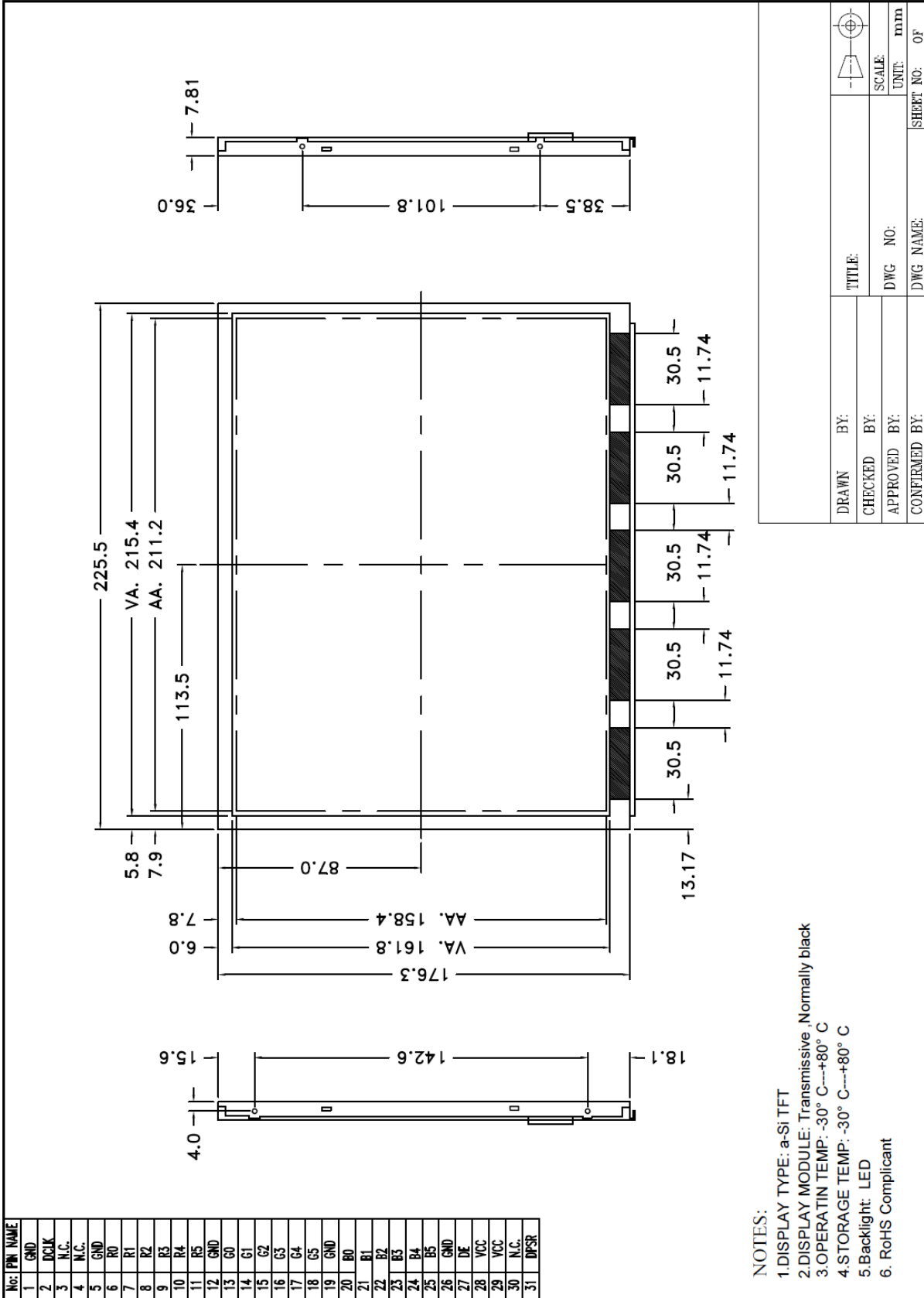

5. Interface signals

Pin	Name	Description
1	GND	Ground
2	DCLK	Dot clock
3	N.C.	N.C.
4	N.C.	N.C.
5	GND	Ground
6	R0	Red data (LSB)
7	R1	Red data
8	R2	Red data
9	R3	Red data
10	R4	Red data
11	R5	Red data (MSB)
12	GND	Ground
13	G0	Green data (LSB)
14	G1	Green data
15	G2	Green data
16	G3	Green data
17	G4	Green data
18	G5	Green data (MSB)
19	GND	Ground
20	B0	Blue data (LSB)
21	B1	Blue data
22	B2	Blue data
23	B3	Blue data
24	B4	Blue data
25	B5	Blue data (MSB)
26	GND	Ground
27	DE	Data enable signal
28	VCC	Power supply
29	VCC	Power supply
30	N.C.	Reserved, please keep it floating.
31	DPSR	Selection of scan direction

Note: Connector Part No.: DF 9C-31P-1V or equivalent.

BACKLIGHT UNIT (Converter connector pin):

Pin	Symbol	Description	Remark
1	Vi	Converter input voltage	12V
2	VGND	Converter ground	Ground
3	EN	Enable pin	
4	ADJ	Backlight Adjust	PWM Dimming
5	NC	Not Connect	

Note 1: Connector Part No.: 3823K-F05N-00L (Entry) or Eqv.

Note 2: Matching connector Part No.: H208K-P05N-02B (Entry) or Eqv.

ASI-T-1040GA6TN/D

6. Absolute maximum Ratings

6.1. Electrical Absolute max. ratings

Parameter	Symbol	MIN	MAX	Unit	Remark
Power Supply Voltage	VCC	-0.3	7.0	V	

For LED Converter:

Parameter	Symbol	MIN	MAX	Unit	Remark
Converter Voltage	Vi	-0.3	18.0	V	
Enable Voltage	EN	--	5.5	V	
Backlight Adjust	ADJ	--	5.5	V	

6.2. Environment Conditions

Item	Symbol	MIN	MAX	Unit	Remark
Operating Temperature	TOPR	-30	80	°C	
Storage Temperature	TSTG	-30	80	°C	

7. Electrical Specifications

7.1 Electrical characteristics

Ta=25°C

Item	Symbol	MIN	TYP	MAX	Unit	Remark	
Power Supply Voltage	VCC	3.0	3.3	3.6	V	at VCC=3.3V	
		4.75	5.0	5.25	V	at VCC=5.0V	
Logic input voltage	VIH	0.7VCC	--	VCC	V		
	VIL	0	--	0.3VCC	V		
Power supply current	white	--	450	490	540	mA	3a, at VCC=3.3V, 60Hz
		--	360	390	440	mA	3a, at VCC=5.0V, 60Hz
	Black	--	420	470	520	mA	3b, at VCC=3.3V, 60Hz
		--	330	380	430	mA	3b, at VCC=5.0V, 60Hz
Power consumption	PL	--	1.617	--	W	VCC=3.3V, 60Hz	

Note 1: The module is recommended to operate within specification ranges listed above for normal function.

Note 2: Measurement conditions:

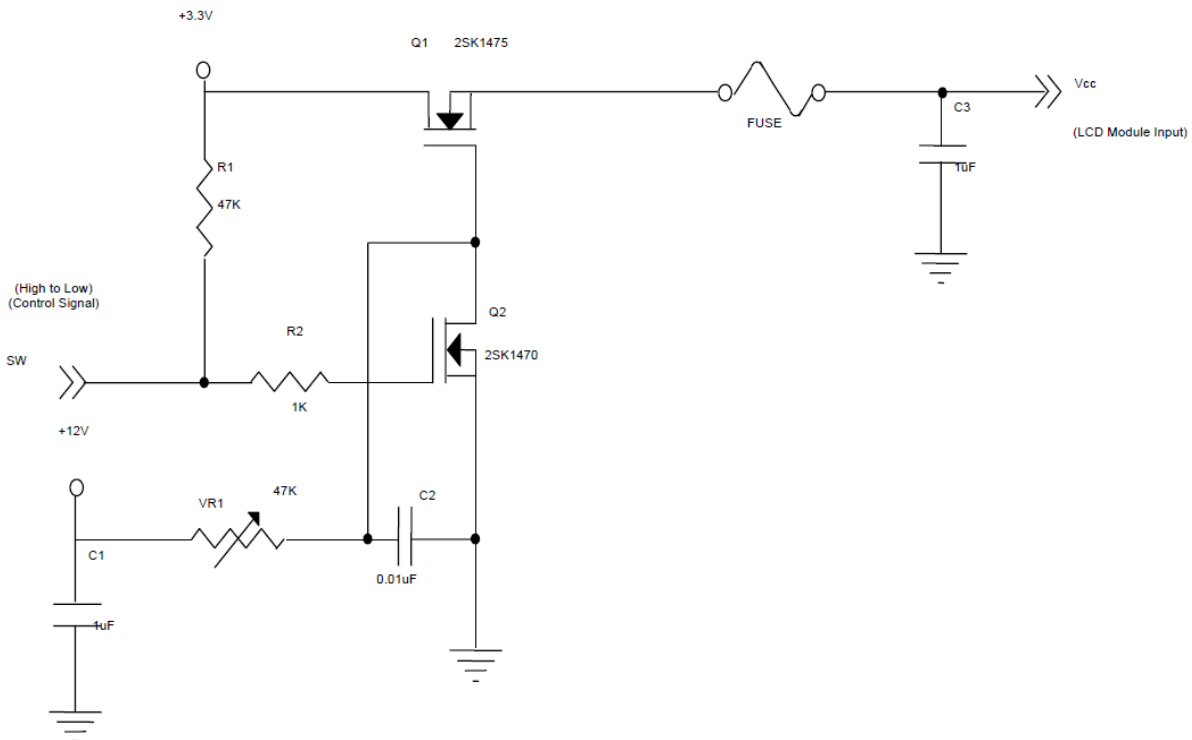

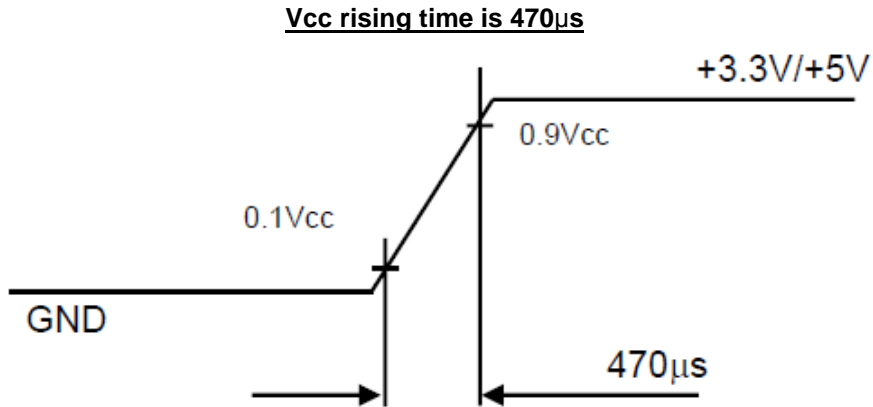

Note 3: The specified power supply current is under the conditions at $T_a = 25 \pm 2 \text{ }^\circ\text{C}$, $f_v = 60\text{Hz}$, whereas a power dissipation check pattern below is displayed.

a. White Pattern



Active Area

b. Black Pattern



Active Area

7.2 LED Converter

$T_a=25^\circ\text{C}$

Item	Symbol	MIN	TYP	MAX	Unit	Remark
Converter power supply current	I_i	--	0.61	--	A	$V_i=12V_y$ (100% Duty)
Converter power supply voltage	V_i	10.8	12.0	12.6	V	100% Duty
LED Power consumption	P_i	--	7.32	--	W	$V_i=12V_y$ (100% Duty)
EN control level	B/L on	2.0	3.3	5.0	V	
	B/L off	0	--	0.8	V	
PWM control level	High level	2.0	3.3	5.0	V	
	Low level	0	--	0.8	V	
PWM control duty ratio		20	--	100	%	
PWM control frequency	f_{PWM}	190	200	20K	Hz	

Note: LED current is measured by utilizing a high frequency current meter as shown below:

ASI-T-1040GA6TN/D

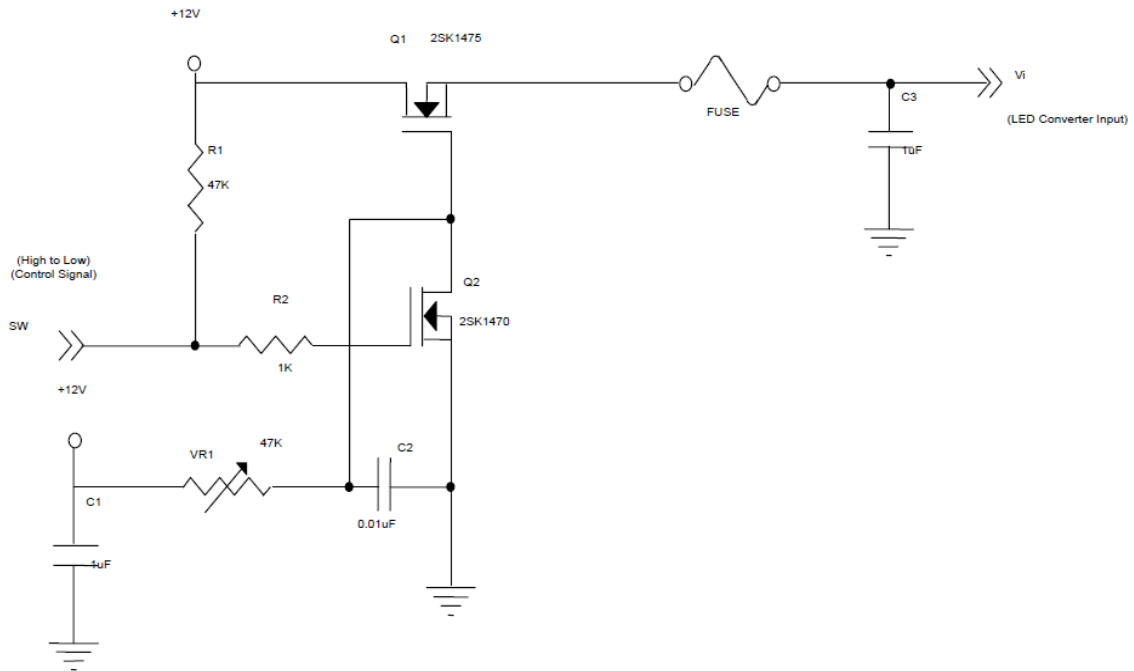
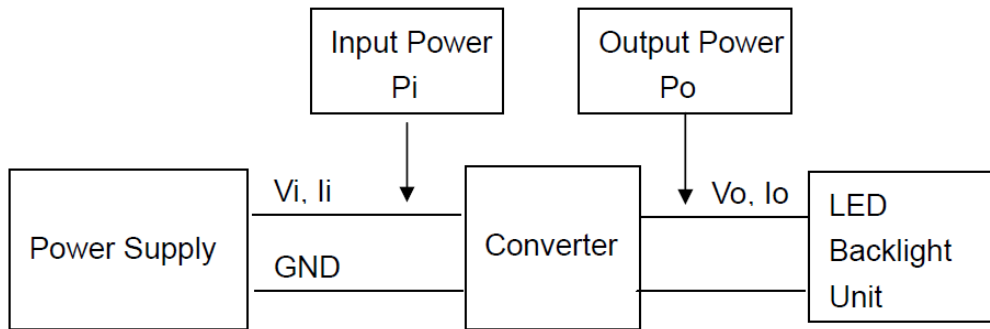

V_i rising time is 470us

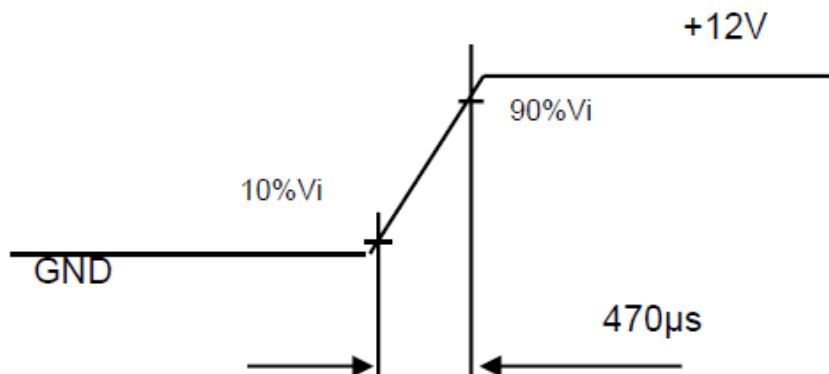

7.3 BLOCK DIAGRAM for TFT-LCD MODULE

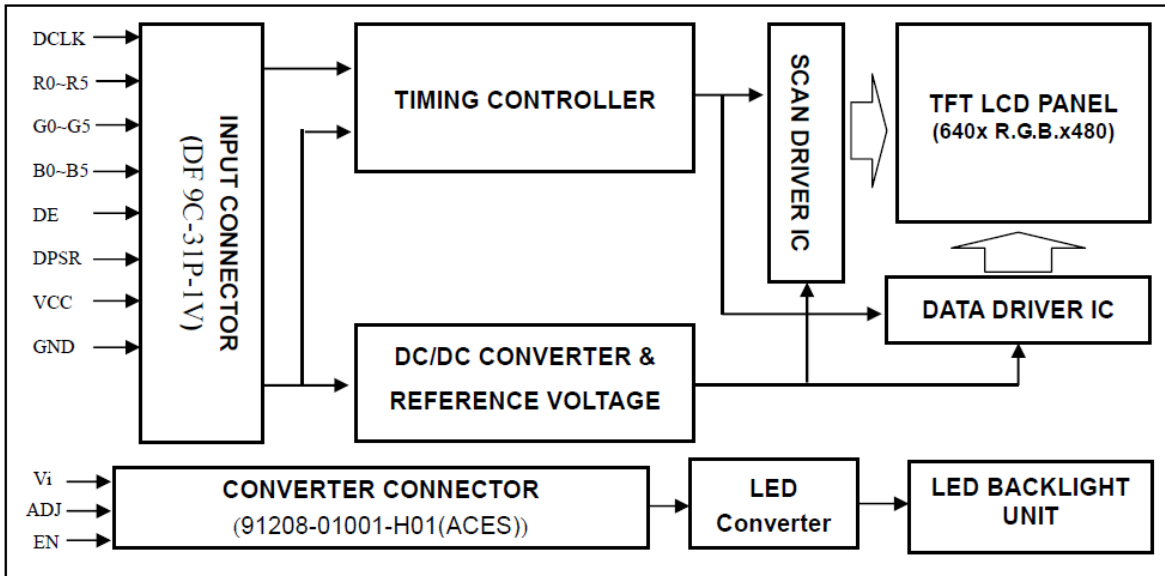

7.4 Color data input assignment

The brightness of each primary color (red, green and blue) is based on the 6-bit gray scale data input for the color. The higher the binary input, the brighter the color. The table below provides the assignment of color versus data input.

Color		Data Signal																	
		Red						Green						Blue					
		R5	R4	R3	R2	R1	R0	G5	G4	G3	G2	G1	G0	B5	B4	B3	B2	B1	B0
Basic Colors	Black	0	0	0	0	0	0	0	0	0	0	0	0	0	0	0	0	0	0
	Red	1	1	1	1	1	1	0	0	0	0	0	0	0	0	0	0	0	0
	Green	0	0	0	0	0	0	0	1	1	1	1	1	0	0	0	0	0	0
	Blue	0	0	0	0	0	0	0	0	0	0	0	0	0	1	1	1	1	1
	Cyan	0	0	0	0	0	0	1	1	1	1	1	1	1	1	1	1	1	1
	Magenta	1	1	1	1	1	1	0	0	0	0	0	0	1	1	1	1	1	1
	Yellow	1	1	1	1	1	1	1	1	1	1	1	1	0	0	0	0	0	0
	White	1	1	1	1	1	1	1	1	1	1	1	1	1	1	1	1	1	1
Gray Scale Of Red	Red(0)/Dark	0	0	0	0	0	0	0	0	0	0	0	0	0	0	0	0	0	0
	Red(1)	0	0	0	0	0	1	0	0	0	0	0	0	0	0	0	0	0	0
	Red(2)	0	0	0	0	1	0	0	0	0	0	0	0	0	0	0	0	0	0
	:	:	:	:	:	:	:	:	:	:	:	:	:	:	:	:	:	:	:
	:	:	:	:	:	:	:	:	:	:	:	:	:	:	:	:	:	:	:
	:	:	:	:	:	:	:	:	:	:	:	:	:	:	:	:	:	:	:
	Red(61)	1	1	1	1	0	1	0	0	0	0	0	0	0	0	0	0	0	0
Red(62)	1	1	1	1	1	0	0	0	0	0	0	0	0	0	0	0	0	0	
Red(63)	1	1	1	1	1	1	0	0	0	0	0	0	0	0	0	0	0	0	
Gray Scale Of Green	Green(0)/Dark	0	0	0	0	0	0	0	0	0	0	0	0	0	0	0	0	0	0
	Green(1)	0	0	0	0	0	0	0	0	0	0	0	1	0	0	0	0	0	0
	Green(2)	0	0	0	0	0	0	0	0	0	0	1	0	0	0	0	0	0	0
	:	:	:	:	:	:	:	:	:	:	:	:	:	:	:	:	:	:	:
	:	:	:	:	:	:	:	:	:	:	:	:	:	:	:	:	:	:	:
	:	:	:	:	:	:	:	:	:	:	:	:	:	:	:	:	:	:	:
	Green(61)	0	0	0	0	0	0	1	1	1	1	0	1	0	0	0	0	0	0
Green(62)	0	0	0	0	0	0	1	1	1	1	1	0	0	0	0	0	0	0	
Green(63)	0	0	0	0	0	0	1	1	1	1	1	1	0	0	0	0	0	0	
Gray Scale Of Blue	Blue(0)/Dark	0	0	0	0	0	0	0	0	0	0	0	0	0	0	0	0	0	0
	Blue(1)	0	0	0	0	0	0	0	0	0	0	0	0	0	0	0	0	0	1
	Blue(2)	0	0	0	0	0	0	0	0	0	0	0	0	0	0	0	0	0	1
	:	:	:	:	:	:	:	:	:	:	:	:	:	:	:	:	:	:	:
	:	:	:	:	:	:	:	:	:	:	:	:	:	:	:	:	:	:	:
	:	:	:	:	:	:	:	:	:	:	:	:	:	:	:	:	:	:	:
	Blue(61)	0	0	0	0	0	0	0	0	0	0	0	0	1	1	1	1	0	1
Blue(62)	0	0	0	0	0	0	0	0	0	0	0	0	1	1	1	1	1	0	
Blue(63)	0	0	0	0	0	0	0	0	0	0	0	0	1	1	1	1	1	1	

Note: 0: Low Level Voltage, 1: High Level Voltage

8. Command/AC Timing

8.1 Input signal timing specifications

The input signal timing specifications are shown as the following table and timing diagram.

Signal	Item	Symbol	Min.	Typ.	Max.	Unit	Note
Dot Clock	Frequency	Fc	21	25.175	29	MHz	-
	Duty		0.4	0.5	0.6		
Dot Data	Setup Time	Tlvs	8	-	-	ns	-
	Hold Time	Tlvh	12	-	-	ns	-
Horizontal Active Display Term	Frame Rate	Fr	-	60	-	Hz	Tv=Tvd+Tvb
	Total	Tv	730	800	900	Th	-
	Display	Tvd		640		Th	-
	Blank	Tvb	90	160	260	Th	-
Vertical Active Display Term	Total	Th	485	525	800	Tc	Th=Thd+Thb
	Display	Thd		480		Tc	-
	Blank	Thb	5	45	320	Tc	-

Note : (1) This module is operated by DE only mode
 (2) Frame rate is 60Hz

INPUT SIGNAL TIMING DIAGRAM

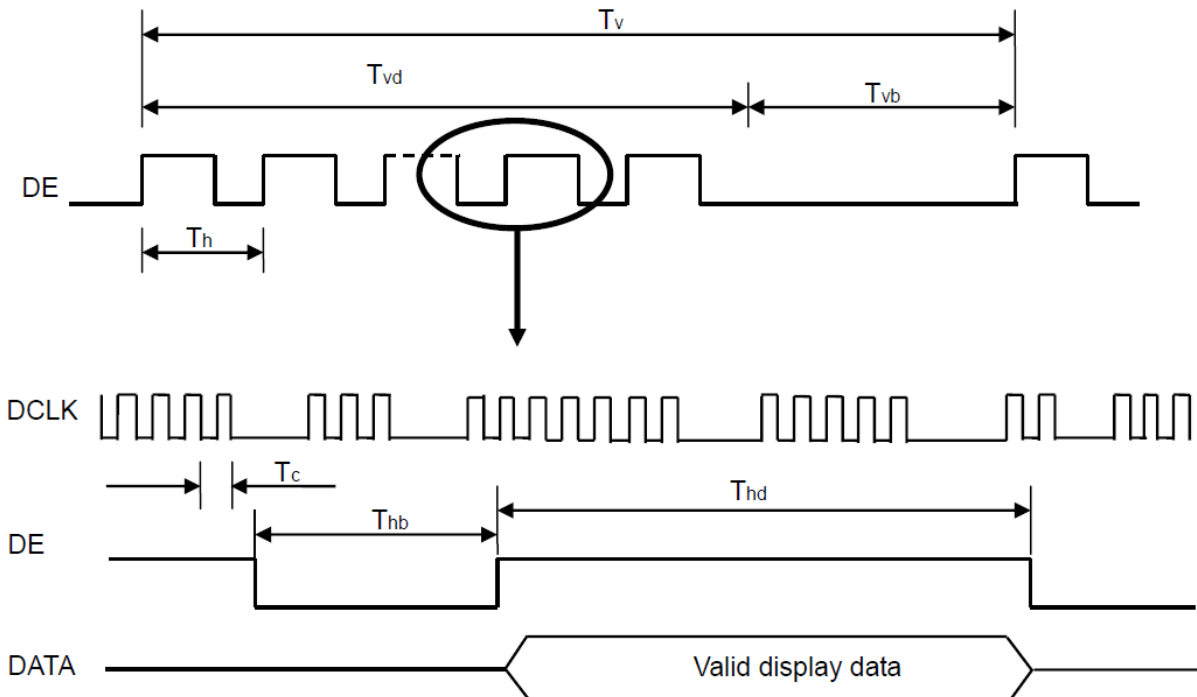

8.2 Power on/off sequence

To prevent a latch-up or DC operation of LCD assembly, the power on/off sequence should be as the diagram below.

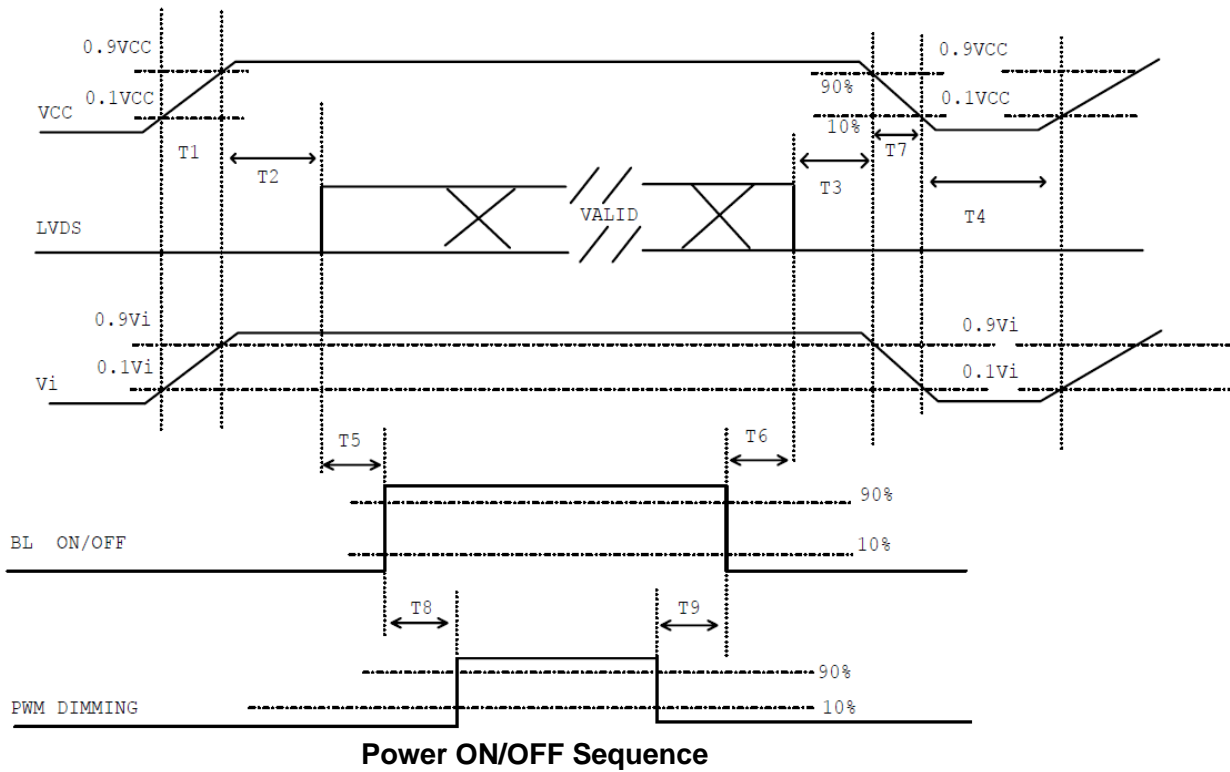

- Note (1) Please avoid floating state of interface signal at invalid period.
- Note (2) When the interface signal is invalid, be sure to pull down the power supply of LCD VCC to 0 V.
- Note (3) The Backlight converter power must be turned on after the power supply for the logic and the interface signal is valid. The Backlight converter power must be turned off before the power supply for the logic and the interface signal is invalid.

Parameter	Value			Units
	Min	Typ	Max	
T1	0.5	-	10	ms
T2	0	-	50	ms
T3	0	-	50	ms
T4	500	-	-	ms
T5	200	-	-	ms
T6	20	-	-	ms
T7	5	-	300	ms
T8	10	-	-	ms
T9	10	-	-	ms

9. Optical Specification

Ta=25°C

Item	Symbol	Condition	Min	Typ.	Max.	Unit	Remark
Contrast Ratio	CR	$\theta=0^\circ$	1000	--	--		Note1 Note3
Response Time	Tr	25°C	--	14	19	ms	Note1
	Tf		--	9	14	ms	Note4
View Angles	ΘT	$CR \geq 10$	80	88	--	Degree	Note 2
	ΘB		80	88	--		
	ΘL		80	88	--		
	ΘR		80	88	--		
Chromaticity	White	x	Brightness is on	Typ-0.05	Tpy+0.05		Note5, Note1
		y					
	RED	x					
		y					
	GREEN	x					
		y					
	BLUE	x					
		y					
Uniformity	U		75	--	--	%	Note1 Note6
Luminance	L		450	500	--	cd/m ²	Note1 Note7

Note 1: Definition of optical measurement system.

Temperature = 25°C(±3°C)

LED back-light: ON, Environment brightness < 150 lx

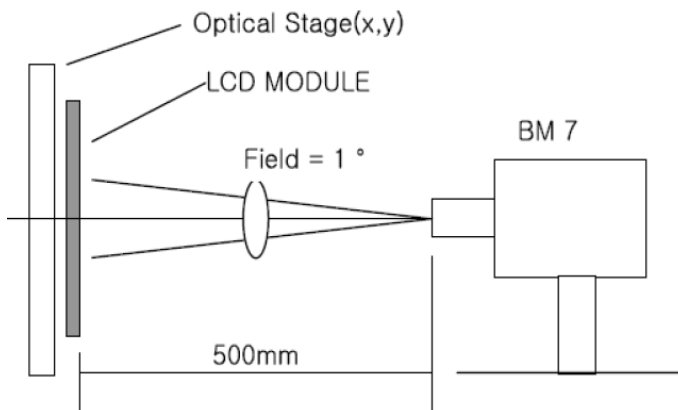

Note 2: Contrast ratio is defined as follow:

$$\text{Contrast Ratio} = \frac{\text{Surface Luminance with all white pixels}}{\text{Surface Luminance with all black pixels}}$$

Note 3: Response time is defined as follow:

Response time is the time required for the display to transition from black to white (Rise Time, T_r) and from white to black (Decay Time, T_f).

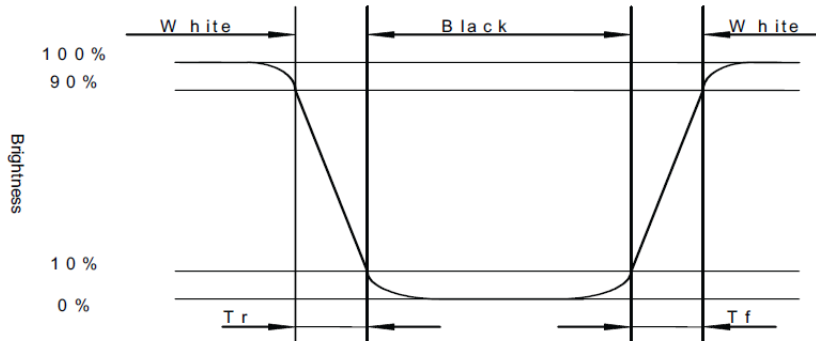

Note 4: Viewing angle range is defined as follow:

Viewing angle is measured at the center point of the LCD.

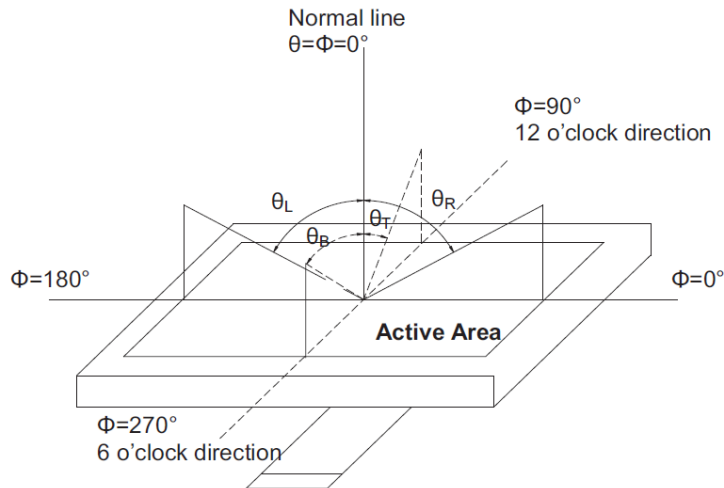

Note 5: Color chromaticity is defined as follow: (CIE1931)

Color coordinates measured at center point of LCD.

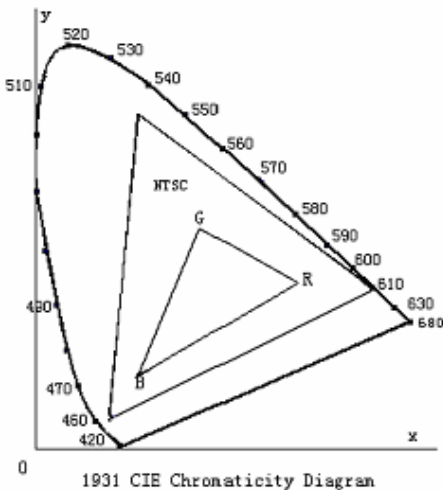

$$S = \frac{\text{area of RGB triangle}}{\text{area of NTSC triangle}} \times 100\%$$

Note 6: Luminance is defined as follow:

Luminance is defined as the brightness of all pixels “White” at the center of display area on optimum contrast.

Note 7: Luminance Uniformity is defined as follow:

Active area is divided into 9 measuring areas (Refer Fig. 2). Every measuring point is placed at the center of each measuring area.

$$\text{Uniformity (U)} = \frac{\text{Minimum Luminance(brightness) in 9 points}}{\text{Maximum Luminance(brightness) in 9 points}}$$

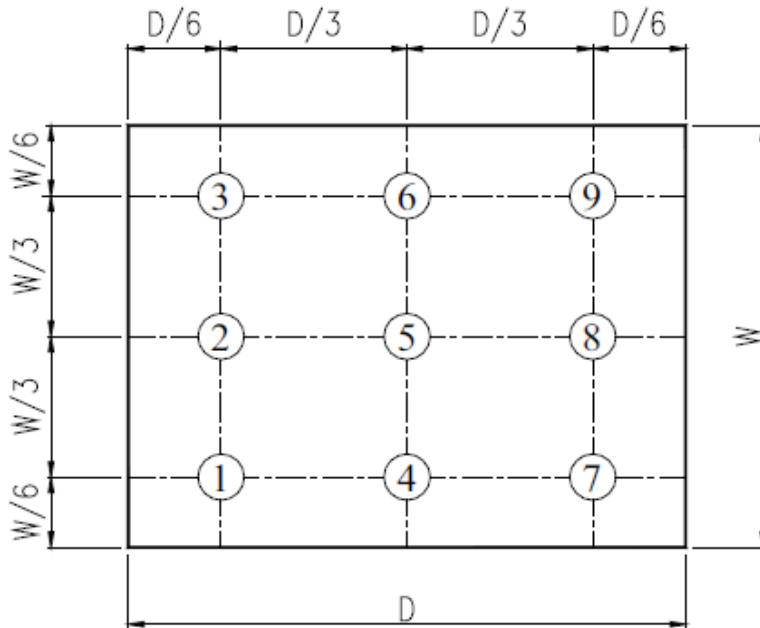

Fig. 2 Definition of uniformity

10. Environmental / Reliability Tests

No	Test Item	Condition	Judgment criteria
1	High Temp Operation	Ts=+80°C, 240hrs	Per table in below
2	Low Temp Operation	Ta=-30°C, 240hrs	Per table in below
3	High Temp Storage	Ts=+80°C, 240hrs	Per table in below
4	Low Temp Storage	Ta=-30°C, 240hrs	Per table in below
5	High Temp & High Humidity Storage	Ta=+60°C, 90% RH 240 hours	Per table in below (polarizer discoloration is excluded)
6	Thermal Shock (Non-operation)	-30°C 30 min~+80°C 30 min, Change time:5min, 100 Cycles	Per table in below
7	ESD (Operation)	C=150pF, R=330Ω 5points/panel Air:±8KV, 5times; Contact:±4KV, 5 times;	Per table in below
8	Vibration (Non-operation)	Frequency range:10~55Hz, Stroke:1.5mm Sweep:10Hz~55Hz~10Hz hours for each direction of X.Y.Z.	2 Per table in below
9	Shock (Non-operation)	100G 6ms, ±X,±Y,±Z 3times, for each direction	Per table in below
10	Package Drop Test	Height:80 cm, 1 corner, 3 edges, 6 surfaces	Per table in below

INSPECTION	CRITERION(after test)
Appearance	No Crack on the FPC, on the LCD Panel
Alignment of LCD Panel	No Bubbles in the LCD Panel No other Defects of Alignment in Active area
Electrical current	Within device specifications
Function / Display	No Broken Circuit, No Short Circuit or No Black line No Other Defects of Display

11. Precautions for Use of LCD Modules

11.1 Safety

The liquid crystal in the LCD is poisonous. Do not put it in your mouth. If the liquid crystal touches your skin or clothes, wash it off immediately using soap and water.

11.2 Handling

- A. The LCD and touch panel is made of plate glass. Do not subject the panel to mechanical shock or to excessive force on its surface.
- B. Do not handle the product by holding the flexible pattern portion in order to assure the reliability
- C. Transparency is an important factor for the touch panel. Please wear clear finger sacks, gloves and mask to protect the touch panel from finger print or stain and also hold the portion outside the view area when handling the touch panel.
- D. Provide a space so that the panel does not come into contact with other components.
- E. To protect the product from external force, put a covering lens (acrylic board or similar board) and keep an appropriate gap between them.
- F. Transparent electrodes may be disconnected if the panel is used under environmental conditions where dew condensation occurs.
- G. Property of semiconductor devices may be affected when they are exposed to light, possibly resulting in IC malfunctions.
- H. To prevent such IC malfunctions, your design and mounting layout shall be done in the way that the IC is not exposed to light in actual use.

11.3 Static Electricity

- A. Ground soldering iron tips, tools and testers when they are in operation.
- B. Ground your body when handling the products.
- C. Power on the LCD module before applying the voltage to the input terminals.
- D. Do not apply voltage which exceeds the absolute maximum rating.
- E. Store the products in an anti-electrostatic bag or container.

11.4 Storage

- A. Store the products in a dark place at $+25^{\circ}\text{C} \pm 10^{\circ}\text{C}$ with low humidity (40% RH to 60% RH). Don't expose to sunlight or fluorescent light.
- B. Storage in a clean environment, free from dust, active gas, and solvent.

11.5 Cleaning

- A. Do not wipe the touch panel with dry cloth, as it may cause scratch.
- B. Wipe off the stain on the product by using soft cloth moistened with ethanol. Do not allow ethanol to get in between the upper film and the bottom glass. It may cause peeling issue or defective operation. Do not use any organic solvent or detergent other than ethanol.

11.6 Cautions for installing and assembling

Bezel edge must be positioned in the area between the Active area and View area. The bezel may press the touch screen and cause activation if the edge touches the active area.

A gap of approximately 0.5mm is needed between the bezel and the top electrode. It may cause unexpected activation if the gap is too narrow. There is a tolerance of 0.2 to 0.3mm for the outside dimensions of the touch panel and tail. A gap must be made to absorb the tolerance in the case and connector.

