



ASI-T-800IA2LN/D

Item	Contents	Unit
Size	8.0	inch
Resolution	1024(RGB) x 768	/
Interface	LVDS	/
Technology type	IPS	/
Pixel Configuration	R.G.B. Vertical Stripe	
Outline Dimension (W x H x D)	174.00x136.00x2.45	mm
Active Area	162.05X121.54	mm
Display Mode	Transmissive,	/
Backlight Type	LED	/
Driver IC	/	/
Weight	TBD	g



Record of Revision

Date	Revision No.	Summary
2015-11-15	1.0	Rev 1.0 was issued
2016-01-19	1.1	Update the Luminance



ASI-T-800IA2LN/D

1. Scope

This data sheet is to introduce the specification of ASI-T-800IA2LN/D active matrix TFT module. It is composed of a color TFT-LCD panel, driver ICs, FPC and a backlight unit. The 8.0" display area contains 1024(RGB) x 768 pixels.

2. Application

Digital equipments which need color display, mobile phone, mobile navigator/video systems.

3. General Information

Item	Contents	Unit
Size	8.0	inch
Resolution	1024(RGB) x 768	/
Interface	LVDS	/
Technology type	IPS	/
Pixel Configuration	R.G.B. Vertical Stripe	
Outline Dimension (W x H x D)	174.00x136.00x2.45	mm
Active Area	162.05X121.54	mm
Display Mode	Transmissive,	/
Backlight Type	LED	/
Driver IC	/	/
Weight	TBD	g

4. Outline Drawing

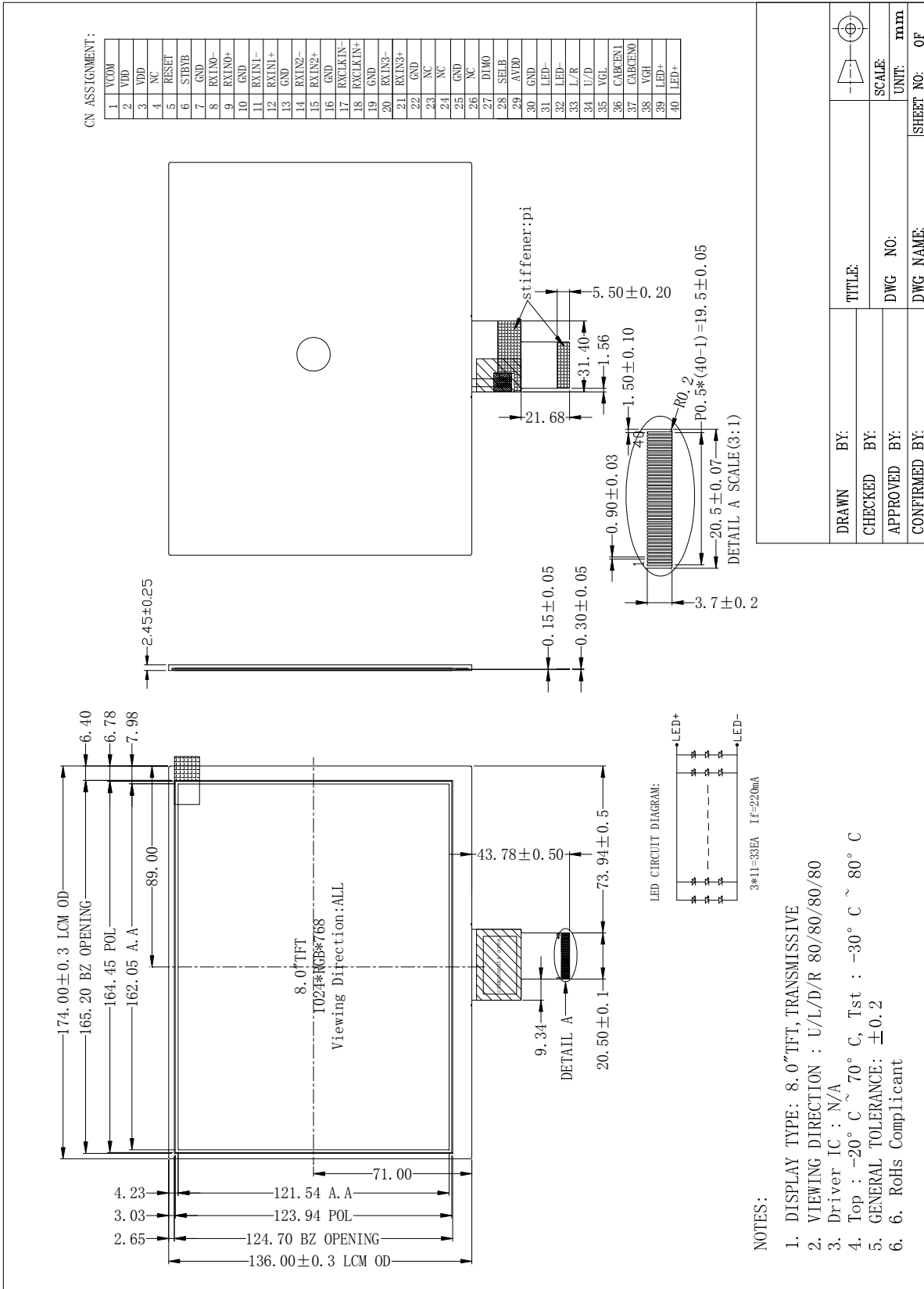



5. Interface signals

Recommend connector: GB5RF40*-1151-7H

Pin No.	Symbol	I/O	Function
1	VCOM	P	Common voltage
2-3	VDD	P	Power for digital circuit
4	NC	-	No connect
5	REST	I	Global reset pin
6	SBYB	I	Stand mode: SBYB=1,normal operation SBYB=0,timing control,source driver will turn off,all output are high-Z
7	GND	P	Ground
8	RXIN0-	I	-LVDS differential data input
9	RXIN0+	I	+LVDS differential data input
10	GND	P	Ground
11	RXIN1-	I	-LVDS differential data input
12	RXIN1+	I	+LVDS differential data input
13	GND	P	Ground
14	RXIN2-	I	-LVDS differential data input
15	RXIN2+	I	+LVDS differential data input
16	GND	P	Ground
17	RXCLKIN-	I	-LVDS differential clock input
18	RXCLKIN+	I	+LVDS differential clock input
19	GND	P	Ground
20	RXIN3-	I	-LVDS differential data input
21	RXIN3+	I	+LVDS differential data input
22	GND	P	Ground
23-24	NC	-	No connection
25	GND	P	Ground
26	NC	-	No connection
27	DIMO	I	Backlight CABC controller signal output
28	SELB	I	6bit/8bit select H:6bit, L:8bit
29	AVDD	P	Power for analog circuit
30	GND	P	Ground
31-32	LED-	P	LED Cathode
33	L/R	I	Horizontal inversion
34	U/D	I	Vertical inversion
35	VGL	P	Negative power for TFT
36	CABCEN1	I	CABC H/W enable



37	CABCEN0	I	CABC H/W enable
38	VGH	P	Positive power for TFT
39-40	LED+	P	LED Anode

NOTE:

Note1: If LVDS inout data is 6 bit, SELB must be set high
 If LVDS inout data is 8 bit, SELB must be set low.

Note2:

SHLR	UPDN	Data shifting
DVDD	GND	Left→Right · Up→Down(default)
GND	GND	Right→Left · Up→Down
DVDD	DVDD	Left→Right · Down→Up
GND	DVDD	Right→Left · Down→Up



6. Absolute maximum Ratings

6.1. Electrical Absolute max. ratings

Item	Symbol	Min.	Max.	Unit	Note
Power Supply Voltage	V _{DD}	-0.3	5.0	V	
	AV _{DD}	6.5	13.5	V	
	V _{GH}	-0.3	40.0	V	
	V _{GL}	-20	0.3	V	
	V _{GH} -V _{GL}	-	40.0	V	

Notes:

1. If the module is above these absolute maximum ratings. It may become permanently damaged. Using the module within the following electrical characteristic conditions are also exceeded, the module will malfunction and cause poor reliability.
2. V_{CC} > V_{SS} must be maintained.

6.2. Environment Conditions

Item	Symbol	MIN	MAX	Unit	Remark
Operating Temperature	TOPR	-20	70	°C	
Storage Temperature	TSTG	-30	80	°C	

Note:

1. The response time will become lower when operated at low temperature.
2. Background color changes slightly depending on ambient temperature.
The phenomenon is reversible.
3. Ta<=40°C:85%RH MAX.
Ta>=40°C:Absolute humidity must be lower than the humidity of 85%RH at 40°C.

7. Electrical Specifications

7.1 Electrical characteristics

GND=0V, Ta=25°C

Parameter	Symbol	Condition	Min	Typ	Max	Unit	Note	
Power supply	VDD	Ta=25°C	3.0	3.3	3.6	V		
Input voltage	'H'	V _{IH}	V _{DD} =3.3V	0.8V _{DD}	-	V _{DD}	V	
	'L'	V _{IL}	V _{DD} =3.3V	0	-	0.2V _{DD}	V	
Current Consumption	I _{DD1}	Normal mode	-	35	60	mA	1	
	I _{DD2}	Sleep mode	-	0.05	0.1	mA	1	
Clock Frequency	f _{CLK}	-	-	20	30	MHz		

Note: Tested in 1×1 chessboard pattern.

7.2 LED Backlight

Ta=25°C

Item	Symbol	Min	Typ	Max	Unit	Note
Forward Voltage	V _f	-	9.0	-	V	
Forward Current	I _F	-	220	-	mA	
Life Time	-	-	20000	-	hours	

Note:

1 : The "LED Life time" is defined as the module brightness decrease to 50% original brightness at T=25°C and I_{LED}=220mA. The LED Life time could be decreased if operating I_{LED} is larger than 220mA

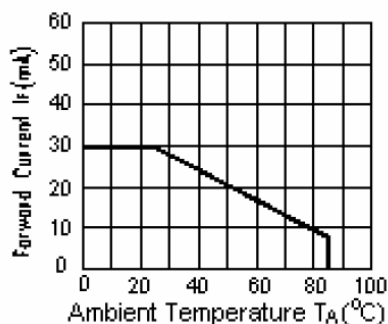

I_{LED} VS TEMP

8. Command/AC Timing

8.1 AC Electrical Characteristics

Parameter	Symbol	Min	Typ	Max	Unit	Remark
Clock Frequency	RxFCLK	20	-	71	MHz	
Input data skew margin	TRSKM	500	-	-	ps	
Clock high time	TLVCH	-	4/(7* RxFCLK)	-	ns	
Clock low time	TLVCL	-	3/(7* RxFCLK)	-	ns	

8.2 Input Clock and Data Timing Diagram

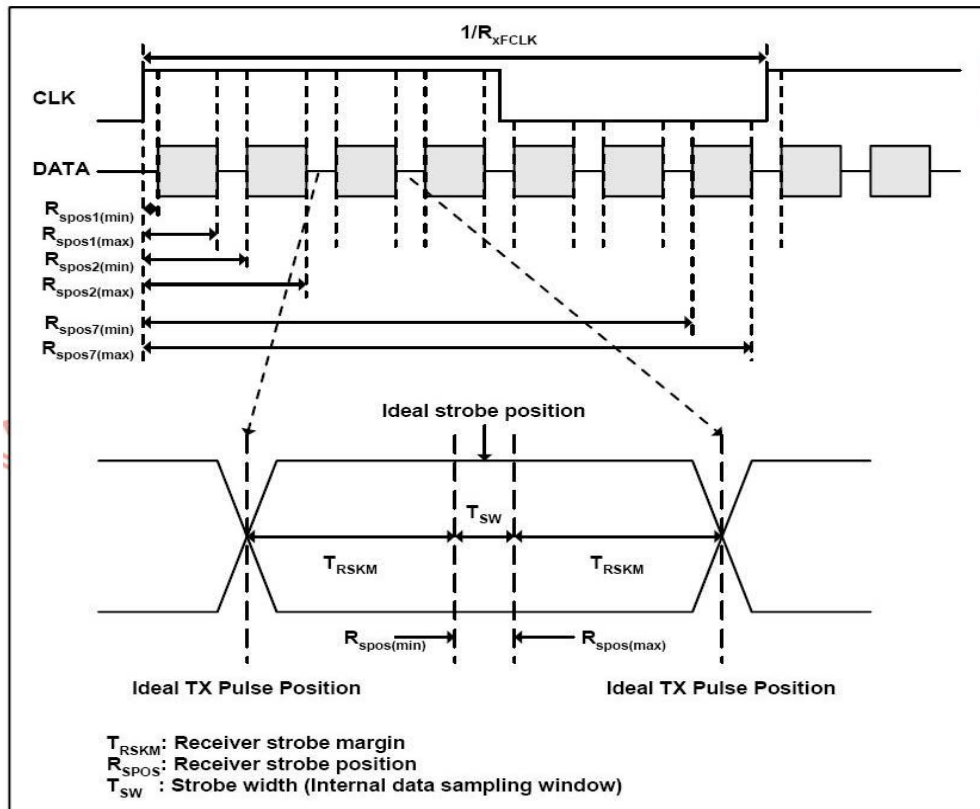

8.3 DC Electrical Characteristics

Parameter	Symbol	Min	Typ	Max	Unit	Remark
Differential input high Threshold voltage	RXVTH	-	-	0.1	V	RXVCM=1.2V
Differential input Low Threshold voltage	RXVTL	-0.1	-	-	V	
Input voltage range	RXVIN	0	-	2.4	V	
Differential input common Mode voltage	RXVCM	$ VID /2$	-	2.4- $ VID /2$	V	
Differential input voltage	$ VID $	0.2	v	0.6	V	
Differential input leakage Current	RVXliz	-10	v	10	uA	

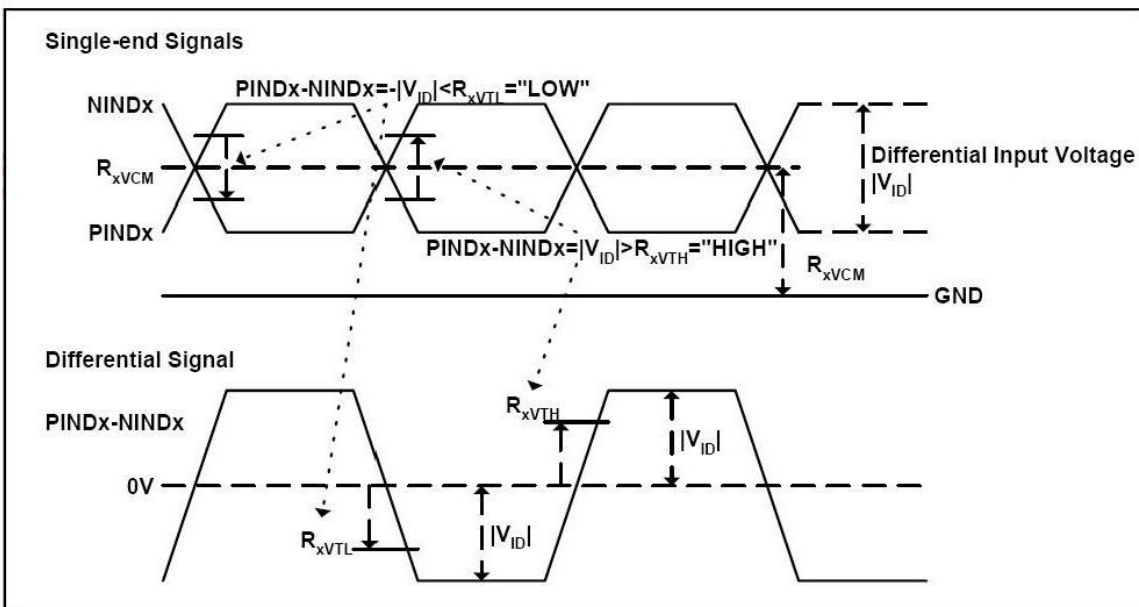

8.4 Timing Table

Parameter	Symbol	Min	Typ	Max	Unit	Remark
Clock frequency	fclk	52	65	71	MHz	
Horizontal display area	thd	1024				
HS period time	th	1114	1344	1400	DCLK	
HS Blanking	thb+thfp	90	320	376	DCLK	
Vertical display area	tvd	768			H	
VS period time	tv	778	806	845	H	
VS Blanking	tvb+tvfp	10	38	77	H	

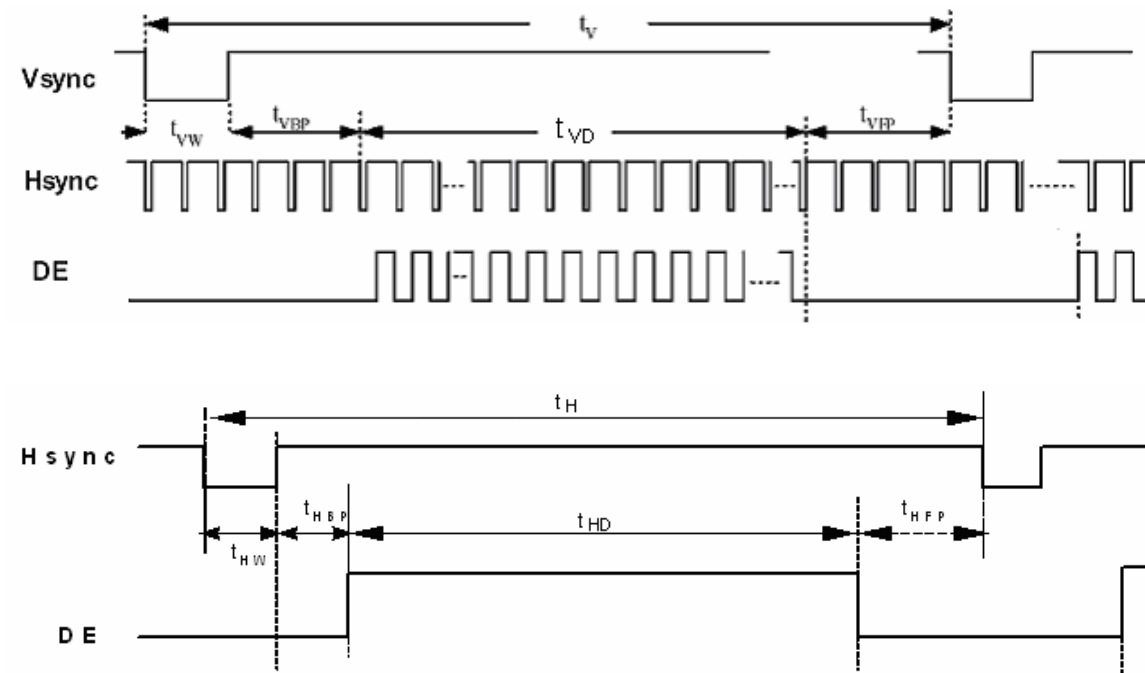

8.5 Date Input Format

6bit LVDS input

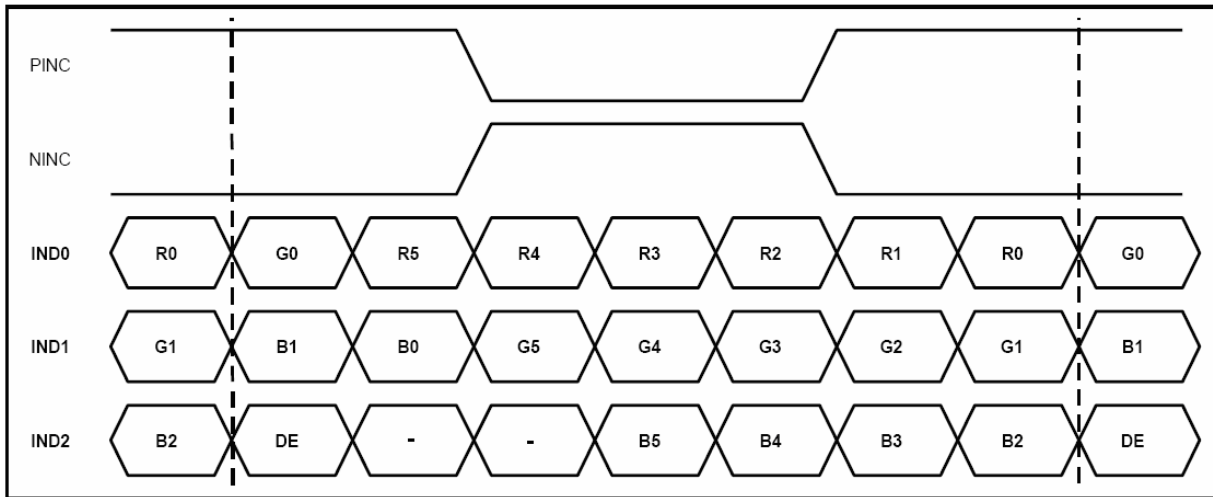

8bit LVDS input

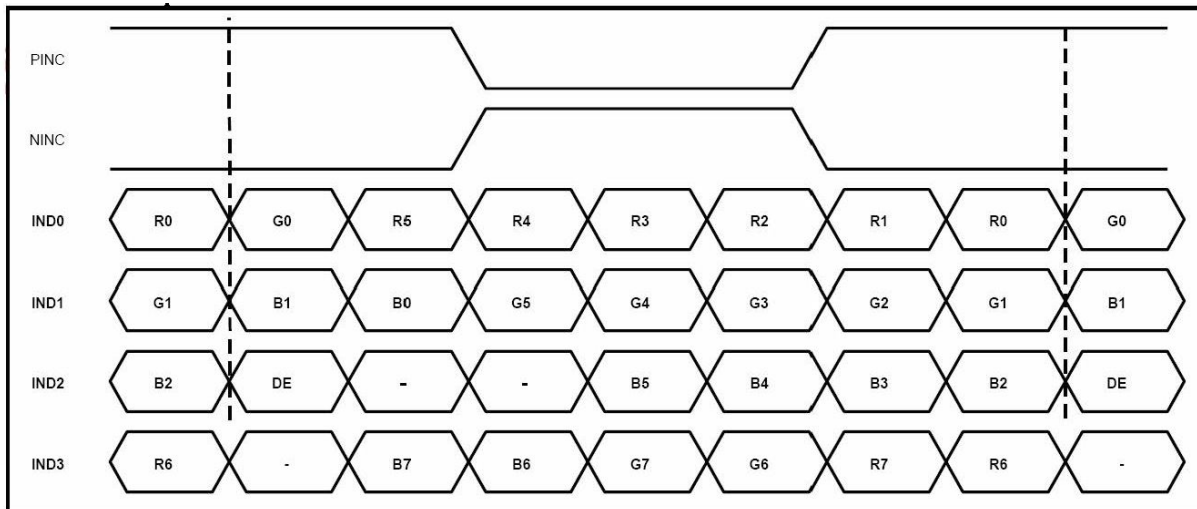

Note: Support DE timing mode only, SYNC mode not supported

8.6 POWER ON/OFF SEQUENCE

a. Power on

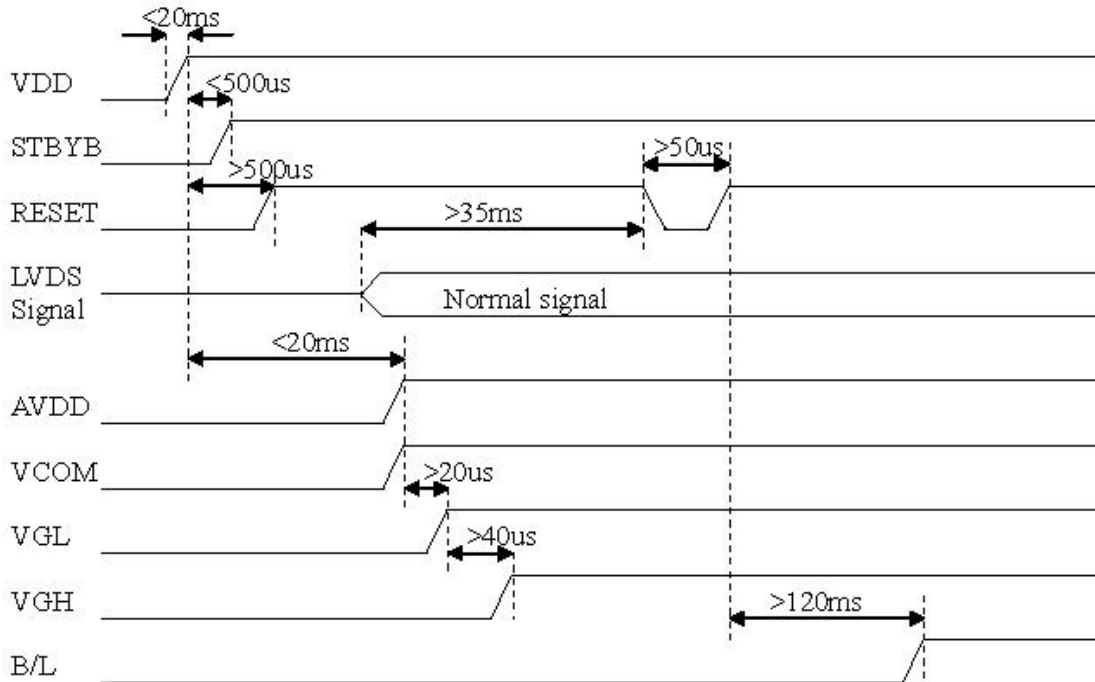

b. Power off:

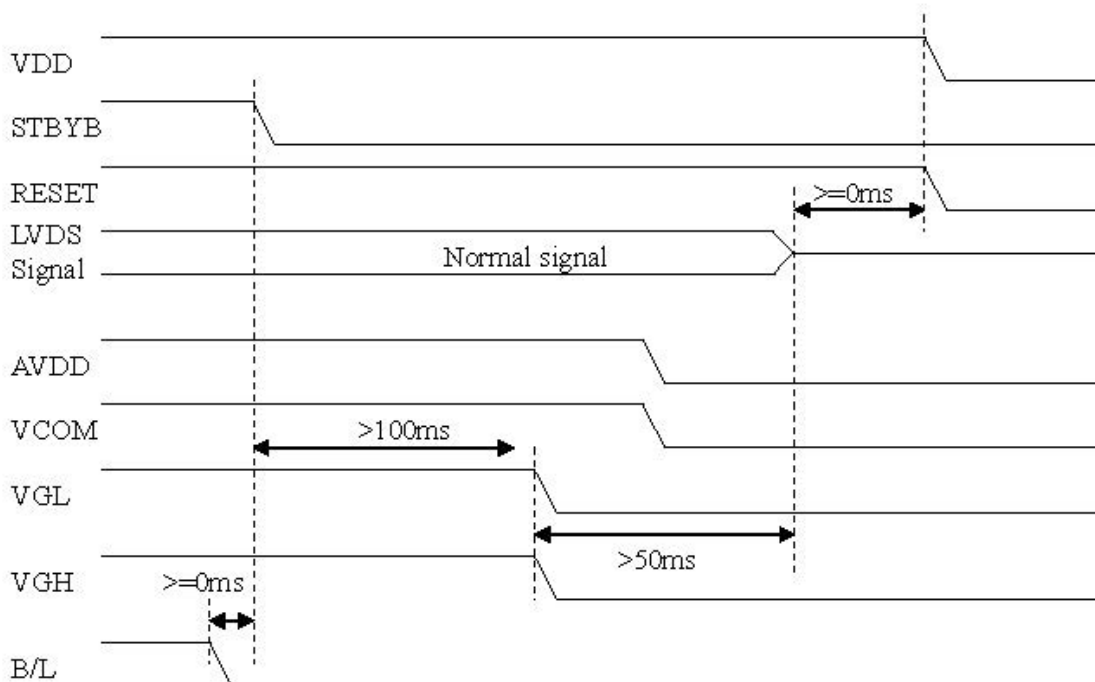

9. Optical Specification

Ta=25°C

Item	Symbol	Condition	Min	Typ.	Max.	Unit	Remark
Contrast Ratio	CR	$\theta=0^\circ$	600	800	-		Note1 Note2
Response Time	Tr	25°C	-	10	-	ms	Note1
	Tf		-	10	-	ms	Note3
View Angles	θT	$CR \geq 10$	-	80	-	Degree	Note 4
	θB		-	80	-		
	θL		-	80	-		
	θR		-	80	-		
Chromaticity	White	Brightness is on	x	0.28	-		Note5, Note1
			y	0.33	-		
	Red		x	0.51	-		
			y	0.34	-		
	Green		x	0.31	-		
			y	0.56	-		
	Blue		x	0.15	-		
			y	0.14	-		
NTSC	S		50	60	--	%	Note5
Luminance	L		200	250	--	cd/m ²	Note1 Note6
Uniformity	U		75	80	--	%	Note1 Note7

Note 1: Definition of optical measurement system.

Temperature = 25°C(±3°C); LED back-light: ON, Environment brightness < 150 lx

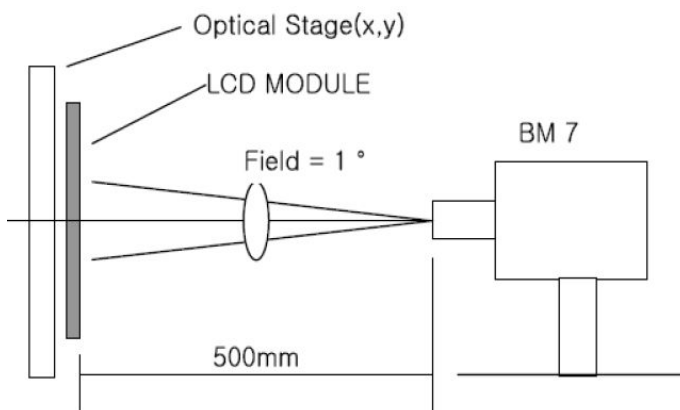

Note 2: Contrast ratio is defined as follow:

$$\text{Contrast Ratio} = \frac{\text{Surface Luminance with all white pixels}}{\text{Surface Luminance with all black pixels}}$$

Note 3: Response time is defined as follow:

Response time is the time required for the display to transition from black to white (Rise Time, T_r) and from white to black(Decay Time, T_f).

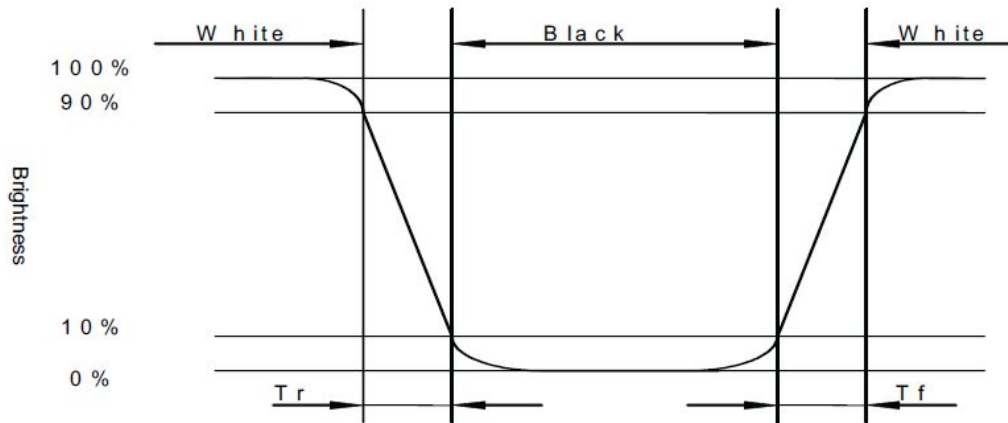

Note 4: Viewing angle range is defined as follow:

Viewing angle is measured at the center point of the LCD.

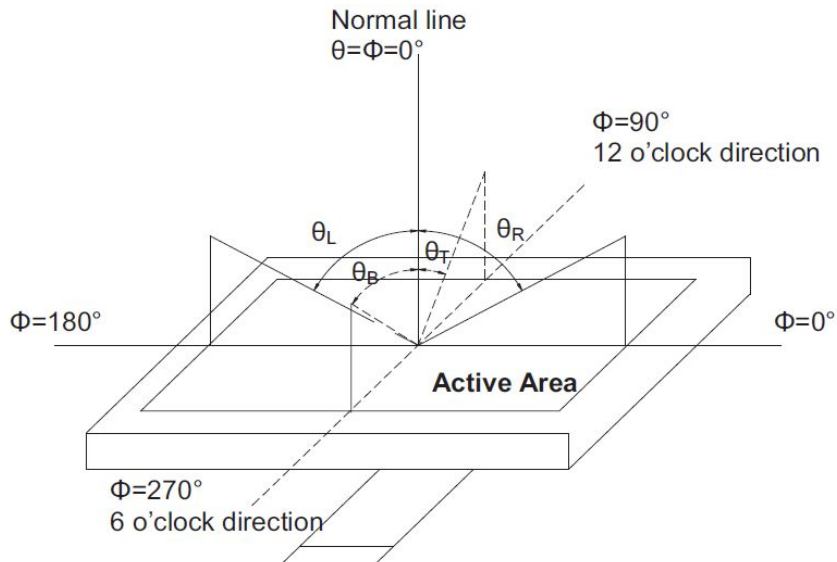

Note 5: Color chromaticity is defined as follow: (CIE1931)

Color coordinates measured at center point of LCD.

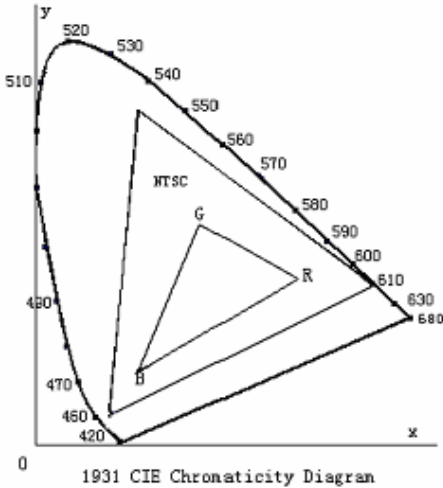

$$S = \frac{\text{area of RGB triangle}}{\text{area of NTSC triangle}} \times 100\%$$

Note 6: Luminance is defined as follow:

Luminance is defined as the brightness of all pixels “White” at the center of display area on optimum contrast.

Note 7: Luminance Uniformity is defined as follow:

Active area is divided into 9 measuring areas (Refer Fig. 2). Every measuring point is placed at the center of each measuring area.

$$\text{Uniformity (U)} = \frac{\text{Minimum Luminance(brightness) in 9 points}}{\text{Maximum Luminance(brightness) in 9 points}}$$

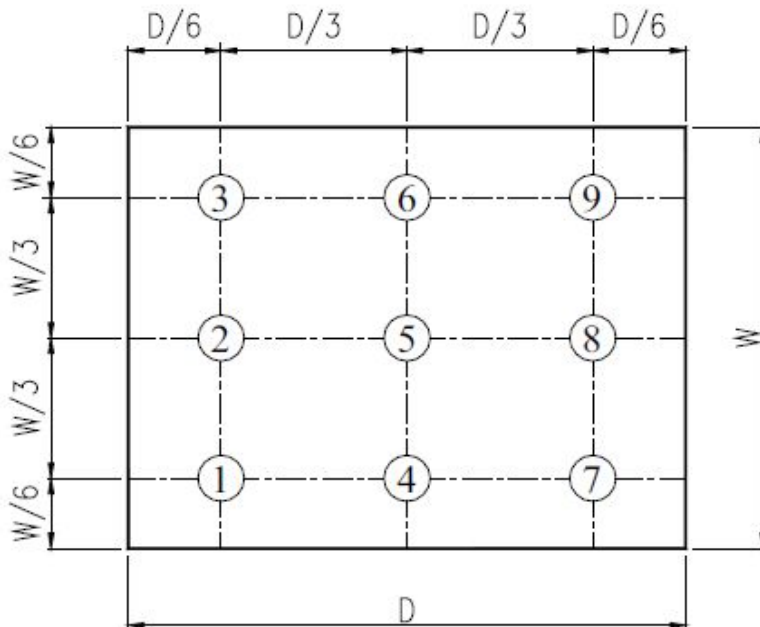

Fig. 2 Definition of uniformity

10. Environmental / Reliability Tests

No	Test Item	Condition	Judgment criteria
1	High Temp Operation	Ts=+70°C, 96hrs	Per table in below
2	Low Temp Operation	Ta=-20°C, 96hrs	Per table in below
3	High Temp Storage	Ta=+80°C, 96hrs	Per table in below
4	Low Temp Storage	Ta=-30°C, 96hrs	Per table in below
5	High Temp & High Humidity Storage	Ta=+60°C, 90% RH 96 hours	Per table in below (polarizer discoloration is excluded)
6	Thermal Shock (Non-operation)	-30°C 30 min~+80°C 30 min, Change time:5min, 5 Cycles	Per table in below
7	ESD (Operation)	C=150pF, R=330Ω , 5points/panel Air:±8KV, 5times; Contact:±4KV, 5 times;	Per table in below
8	Vibration (Non-operation)	10Hz~150Hz, 100m/s ² , 120min	Per table in below
9	Shock (Non-operation)	Half- sine wave,300m/s ² ,11ms	Per table in below
10	Package Drop Test	Height:80 cm, 1 corner, 3 edges, 6 surfaces	Per table in below

INSPECTION	CRITERION(after test)
Appearance	No Crack on the FPC, on the LCD Panel
Alignment of LCD Panel	No Bubbles in the LCD Panel No other Defects of Alignment in Active area
Electrical current	Within device specifications
Function / Display	No Broken Circuit, No Short Circuit or No Black line No Other Defects of Display

11. Precautions for Use of LCD Modules

11.1 Safety

The liquid crystal in the LCD is poisonous. Do not put it in your mouth. If the liquid crystal touches your skin or clothes, wash it off immediately using soap and water.

11.2 Handling

- A. The LCD and touch panel is made of plate glass. Do not subject the panel to mechanical shock or to excessive force on its surface.
- B. Do not handle the product by holding the flexible pattern portion in order to assure the reliability
- C. Transparency is an important factor for the touch panel. Please wear clear finger sacks, gloves and mask to protect the touch panel from finger print or stain and also hold the portion outside the view area when handling the touch panel.
- D. Provide a space so that the panel does not come into contact with other components.
- E. To protect the product from external force, put a covering lens (acrylic board or similar board) and keep an appropriate gap between them.
- F. Transparent electrodes may be disconnected if the panel is used under environmental conditions where dew condensation occurs.
- G. Property of semiconductor devices may be affected when they are exposed to light, possibly resulting in IC malfunctions.
- H. To prevent such IC malfunctions, your design and mounting layout shall be done in the way that the IC is not exposed to light in actual use.

11.3 Static Electricity

- A. Ground soldering iron tips, tools and testers when they are in operation.
- B. Ground your body when handling the products.
- C. Power on the LCD module before applying the voltage to the input terminals.
- D. Do not apply voltage which exceeds the absolute maximum rating.
- E. Store the products in an anti-electrostatic bag or container.

11.4 Storage

- A. Store the products in a dark place at $+25^{\circ}\text{C} \pm 10^{\circ}\text{C}$ with low humidity (40% RH to 60% RH). Don't expose to sunlight or fluorescent light.
- B. Storage in a clean environment, free from dust, active gas, and solvent.

11.5 Cleaning

- A. Do not wipe the touch panel with dry cloth, as it may cause scratch.
- B. Wipe off the stain on the product by using soft cloth moistened with ethanol. Do not allow ethanol to get in between the upper film and the bottom glass. It may cause peeling issue or defective operation. Do not use any organic solvent or detergent other than ethanol.

11.6 Cautions for installing and assembling

Bezel edge must be positioned in the area between the Active area and View area. The bezel may press the touch screen and cause activation if the edge touches the active area. A gap of approximately 0.5mm is needed between the bezel and the top electrode. It may cause unexpected activation if the gap is too narrow. There is a tolerance of 0.2 to 0.3mm for the outside dimensions of the touch panel and tail. A gap must be made to absorb the tolerance in the case and connector.

