



ASI-T-700MA3TN/D

Item	Contents	Unit
Size	7.0	inch
Resolution	800x 3(RGB) x 480	/
Interface	TTL	/
Technology type	a-Si TFT	/
Pixel pitch	0.0635x0.1905	mm
Pixel Configuration	RGB stripes	
Outline Dimension (W x H x D)	165x104x5.5	mm
Active Area	152.4 x 91.44	mm
Display Mode	Transmissive, Normally white	/
Backlight Type	LED	/



Record of Revision

Date	Revision No.	Summary
2009-02-05	1.0	Rev 1.0 was issued

1. Scope

This data sheet is to introduce the specification of ASI-T-700MA3TN/D active matrix TFT module. It is composed of a color TFT-LCD panel, driver ICs, FPC and a backlight unit. The 7.0" display area contains 800X3(RGB) x 480pixels.

2. Application

Digital equipments which need color display, mobile navigator/video systems.

3. General Information

Item	Contents	Unit
Size	7.0	inch
Resolution	800x 3(RGB) x 480	/
Interface	TTL	/
Technology type	a-Si TFT	/
Pixel pitch	0.0635x0.1905	mm
Pixel Configuration	RGB stripes	
Outline Dimension (W x H x D)	165x104x5.5	mm
Active Area	152.4 x 91.44	mm
Display Mode	Transmissive, Normally white	/
Backlight Type	LED	/

4. Outline Drawing

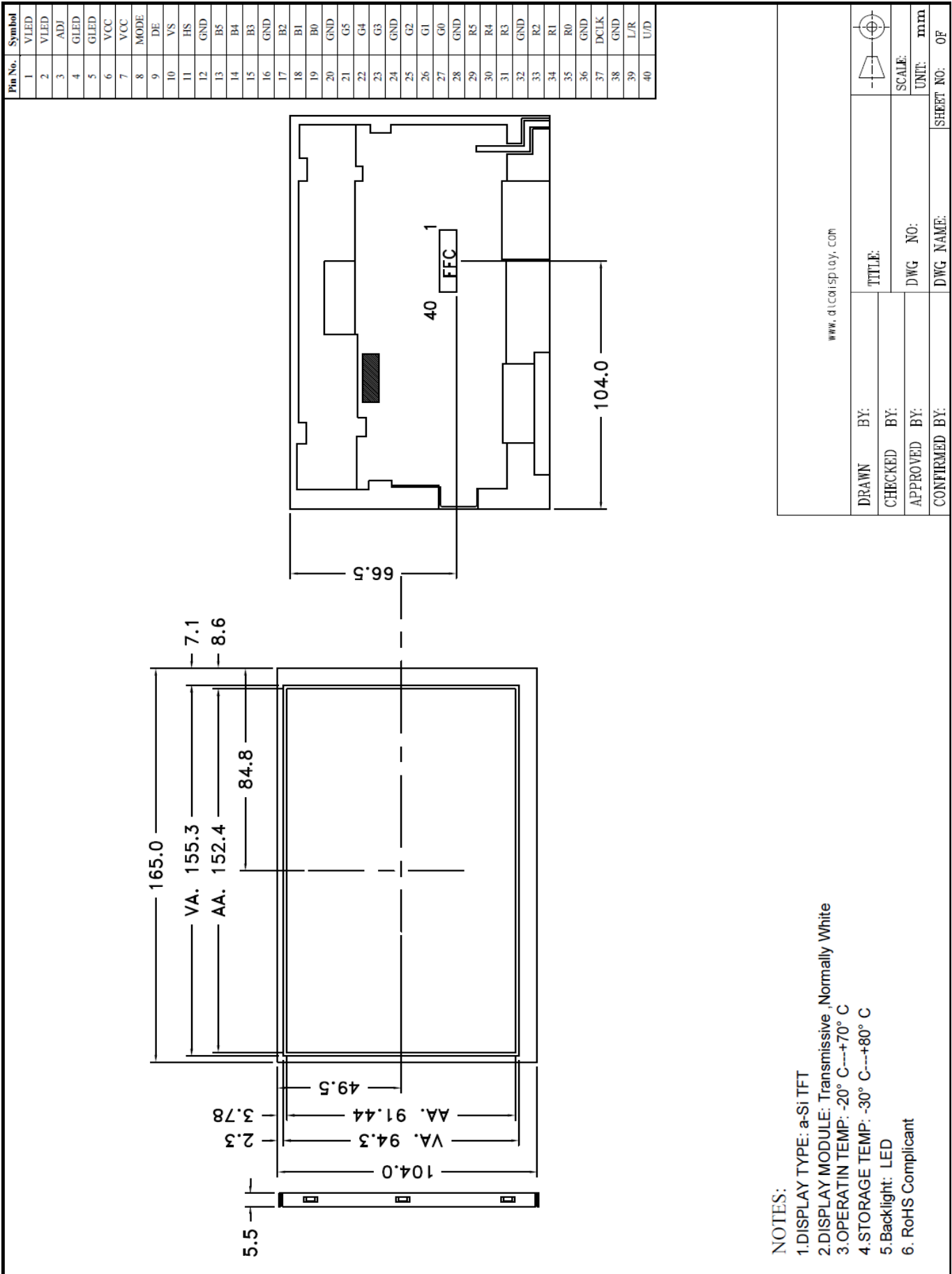

TTL Connector is used for the module electronic interface. The recommended model is "FH33-40S-0.5SH

5. Interface signals

(10)", manufactured by Hirose.

Pin No.	Symbol	I/O	Function	Remark
1	VLED	P	Power supply for LED Driver	
2	VLED	P	Power supply for LED Driver	
3	ADJ	I	Adjust the led brightness with PWM Pulse	Note 1,2
4	GLED	P	Ground for LED circuit	
5	GLED	P	Ground for LED circuit	
6	VCC	P	Power supply for digital circuit	
7	VCC	P	Power supply for digital circuit	
8	MODE	I	DE or HV mode control	Note 3
9	DE	I	Data enable	
10	VS	I	Vsync signal input	
11	HS	I	Hsync signal input	
12	GND	P	Power ground	
13	B5	I	Blue data input (MSB)	
14	B4	I	Blue data input	
15	B3	I	Blue data input	
16	GND	P	Power ground	
17	B2	I	Blue data input	
18	B1	I	Blue data input	
19	B0	I	Blue data input(LSB)	
20	GND	P	Power ground	
21	G5	I	Green data input(MSB)	
22	G4	I	Green data input	
23	G3	I	Green data input	
24	GND	P	Power ground	
25	G2	I	Green data input	
26	G1	I	Green data input	
27	G0	I	Green data input(LSB)	

28	GND	P	Power ground	
29	R5	I	Red data input(MSB)	
30	R4	I	Red data input	
31	R3	I	Red data input	
32	GND	P	Power ground	
33	R2	I	Red data input	
34	R1	I	Red data input	
35	R0	I	Red data input(LSB)	
36	GND	P	Power ground	
37	DCLK	I	Sample clock	
38	GND	P	Power ground	
39	L/R	I	Select left or right scanning direction	Note 4,5
40	U/D	I	Select up or down scanning direction	Note 4,5

Note1: Pin3. is used to adjust brightness.

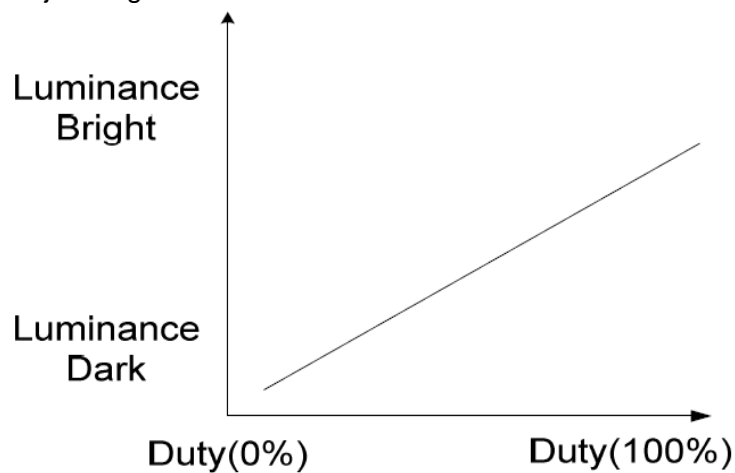

Note 2: ADJ signal=0 ~3.3V; Operating frequency:100~300Hz.

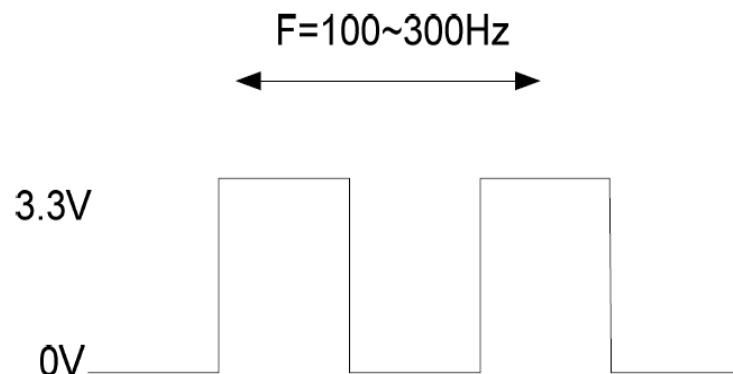

Note 3: DE Mode: Mode="H", HS floating and VS floating.
 HV Mode: Mode="L" and DE floating.

Note 4: Selection of scanning mode

Setting of scan control input		Scanning direction
U/D	L/R	
GND	VCC	Up to down, left to right
VCC	GND	Down to up, right to left
GND	GND	Up to down, right to left
VCC	VCC	Down to up, left to right

Note 5: Scanning direction refer to the figure below.

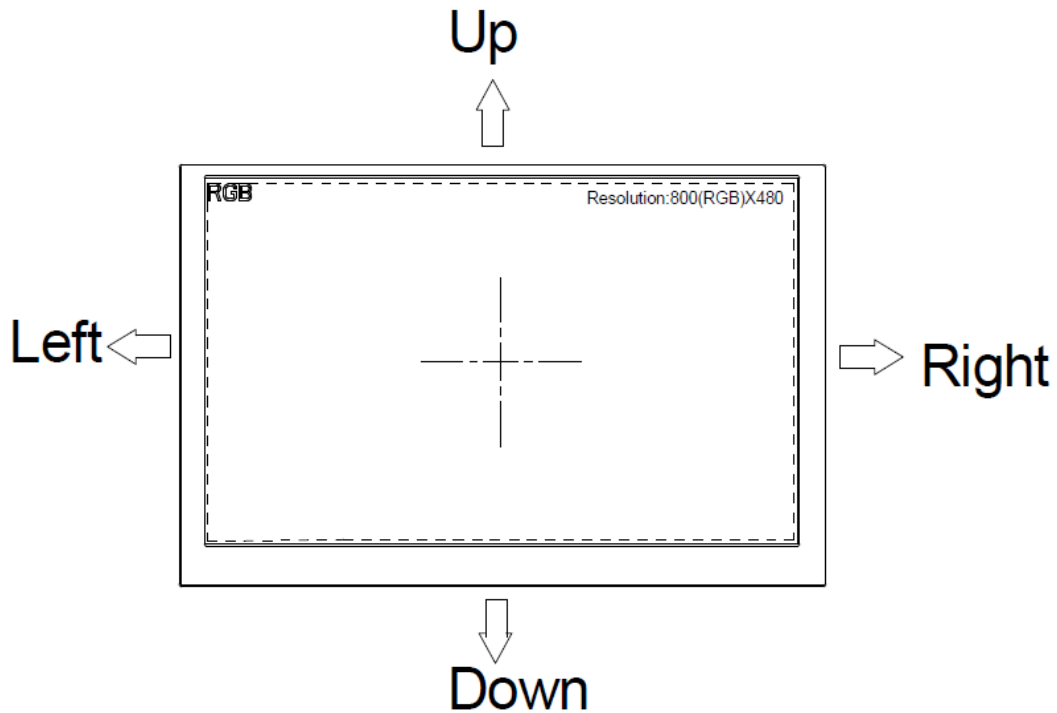

6. Absolute maximum Ratings

6.1. Electrical Absolute max. ratings

Parameter	Symbol	MIN	MAX	Unit	Remark
Power voltage	VCC	-0.3	6.0	V	
Input signal voltage	VI	-0.3	6.3	V	

6.2. Environment Conditions

Item	Symbol	MIN	MAX	Unit	Remark
Operating Temperature	TOPR	-20	70	°C	
Storage Temperature	TSTG	-30	80	°C	

6.3. LED Backlight Absolute max. ratings

Item	Symbol	MIN	MAX	Unit	Remark
LED Power voltage	VLED	--	5.5	V	

7. Electrical Specifications

7.1 Electrical characteristics

Ta=25°C

Item	Symbol	MIN	TYP	MAX	Unit	Remark
Power voltage	VCC	3.1	3.3	3.5	V	Note 1
Current consumption	ICC	--	250	300	mA	
Input Signal Voltage	VIL	0	--	0.3VCC	V	Note 2
	VIH	0.7VCC	--	VCC	V	

Note1: VCC setting should match the signals output voltage (refer to Note 4) of customer's system board.

Note 2: DCLK, DE, HS, VS, R0~ R5,,G0~ G5,B0~ B5.

7.2 LED Backlight

Ta=25°C

Item	Symbol	MIN	TYP	MAX	Unit	Remark
Forward Current	IF	--	500	550	mA	
Forward Voltage	VF	4.8	5.0	5.2	V	

8. Command/AC Timing

8.1 Timing Conditions

Input signal characteristics of SYNC mode.

Item	Symbol	Values			Unit	Remark
		Min.	Typ.	Max.		
Clock Period	tCLK	23.2	25.0	30.7	ns	
Clock Frequency	fCLK	32.4	40	43	MHz	
Clock Low Level Width	tWCL	8	-	-	ns	
Clock High Level Width	tWCH	8	-	-		
Clock Rise/Fall Time	tCLKr, tCLKf	-	-	3		
HSYNC Period	tHP	862	1056	1100	tCLK	
HSYNC Pulse Width	tHW	-	1	-	tCLK	
HSYNC Back Porch	tHBP	-	45	-	tCLK	
HSYNC Width + Back Porch	tHW + tHBP	46			tCLK	
Horizontal valid data width	tHV	800			tCLK	
HSYNC Front Porch	tHFP	tHP -tHW -tHBP -tHV			tCLK	
Horizontal Blank	tHBK	tHP -tHV			tCLK	
VSYNC Period	tVP	628	635	650	tHP	
VSYNC Pulse Width	tVW	-	1	-	tHP	
VSYNC Back Porch	tVBP	22			tHP	
Vertical valid data width	tw	480			tHP	
Vertical Front Porch	tVFP	tVP -tVW -tVBP -tw			tHP	
Vertical Blank	tVBK	tVP -tw			tHP	
Data Setup Time	tDS	5	-	-	ns	
Data Hold Time	tDH	10	-	-	ns	

Input signal characteristics of DE mode.

Item		Symbol	Values			Unit	Remark
			Min.	Typ.	Max.		
DCLK	Period	tCLK	23.2	25.0	30.7	ns	
	Frequency	fCLK	32.4	40	43	MHz	
	Low Level Width	tWCL	6	-	-	ns	
	High Level Width	tWCH	6	-	-		
	Rise/Fall Time	tCLKr, tCLKf	-	-	3		
	Duty	-	0.45	0.50	0.55	-	tCLKL/ tCLK
DE	Setup Time	tDES	5	-	-	ns	
	Hold Time	tDEH	10	-	-		
	Rise/Fall Time	tDEr, tDEf	-	-	16		
	Horizontal Period	tHP	862	1056	1100	tCLK	
	Horizontal Valid	tHV	800				
	Horizontal Blank	tHBK	tHP -tHV				
	Vertical Period	tVP	628	635	650	tHP	
	Vertical Valid	tw	480				
	Vertical Blank	tVBK	tVP -tw				
DATA	Setup Time	tDS	5	-	-	ns	
	Hold Time	tDH	10	-	-		
	Rise/Fall Time	tDr, tDf	-	-	3		

8.2 Timing Diagram

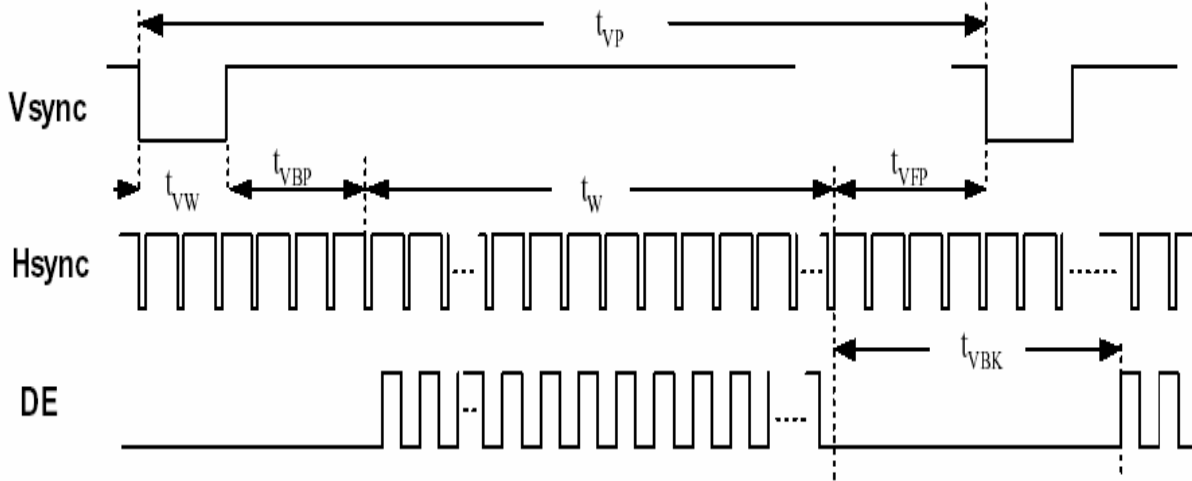

Input Vertical Timing

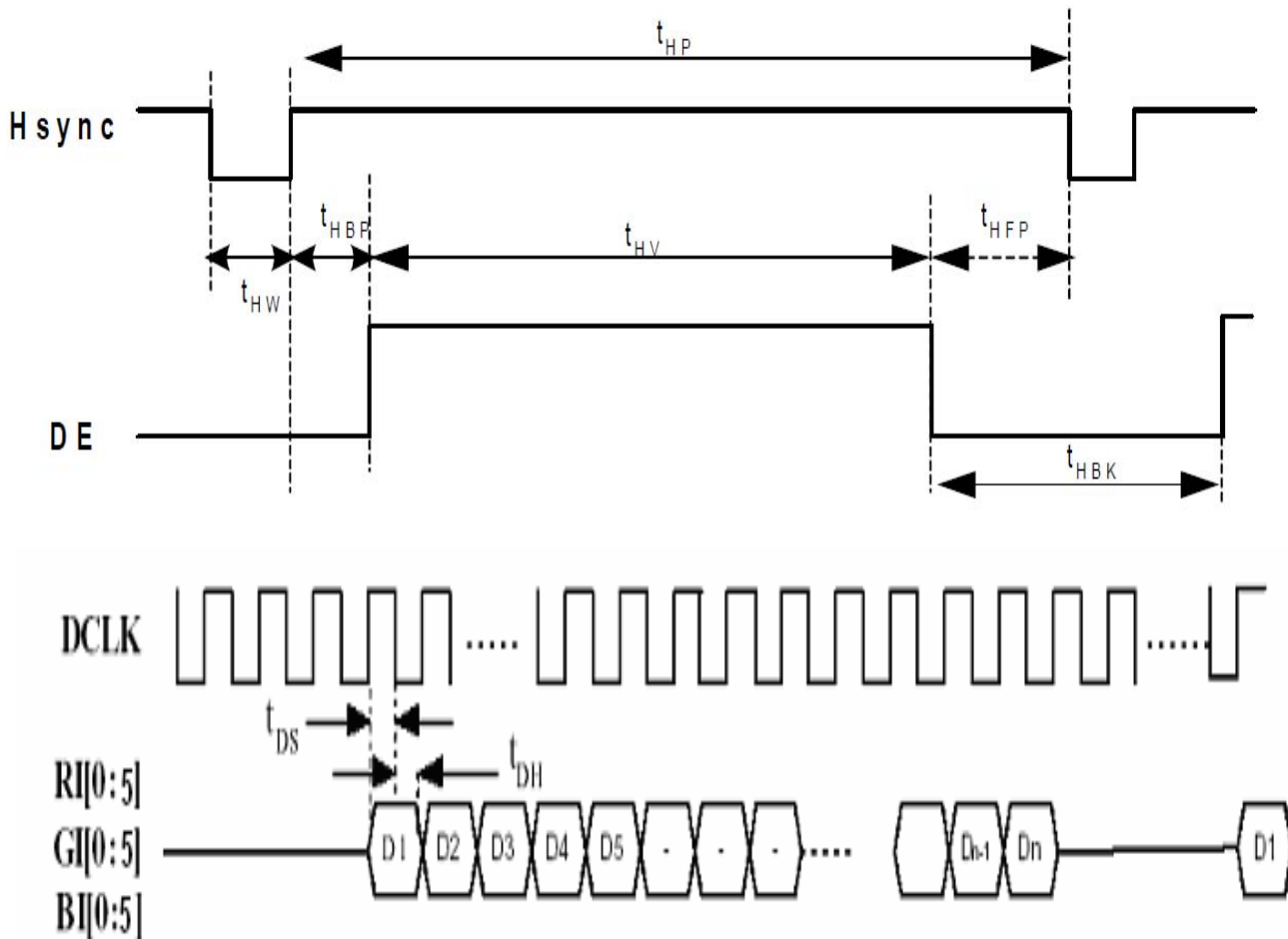

Input Horizontal Timing

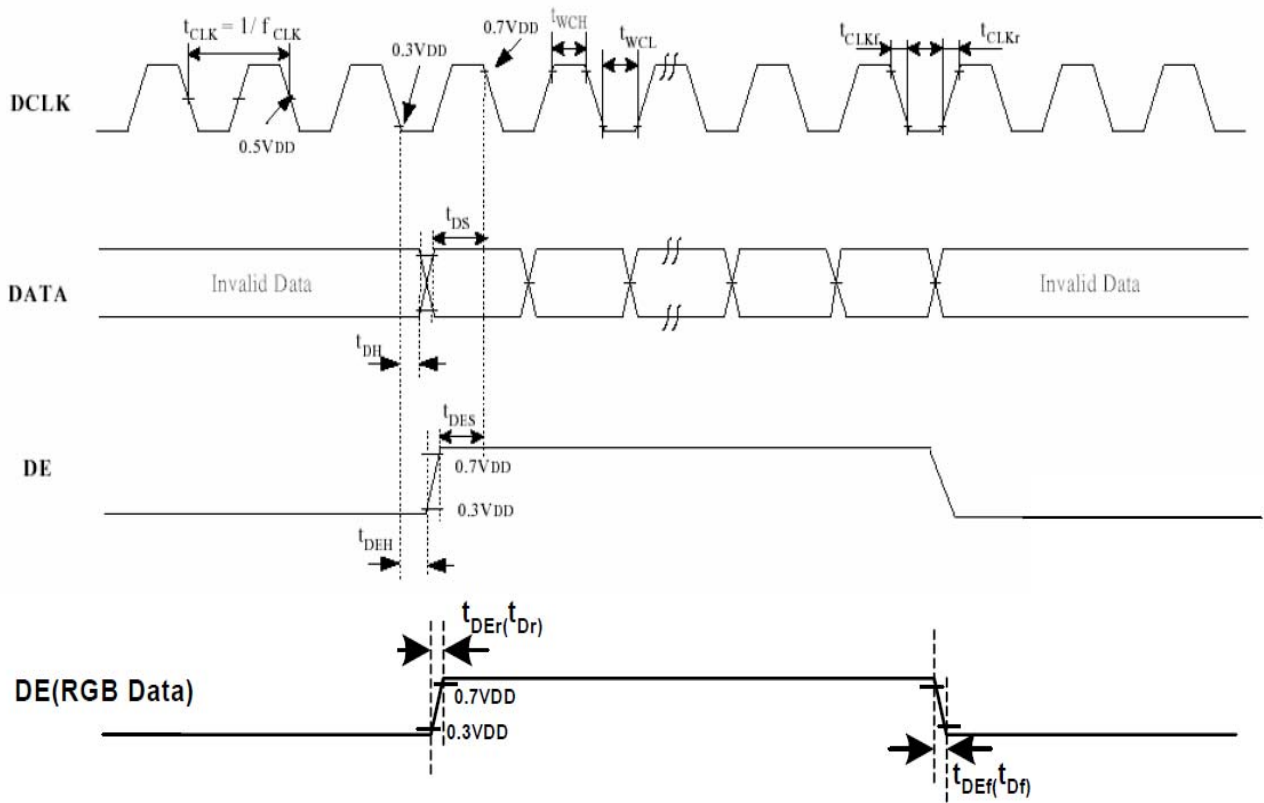

DE and RGB Input Timing

8.3 Power Sequence

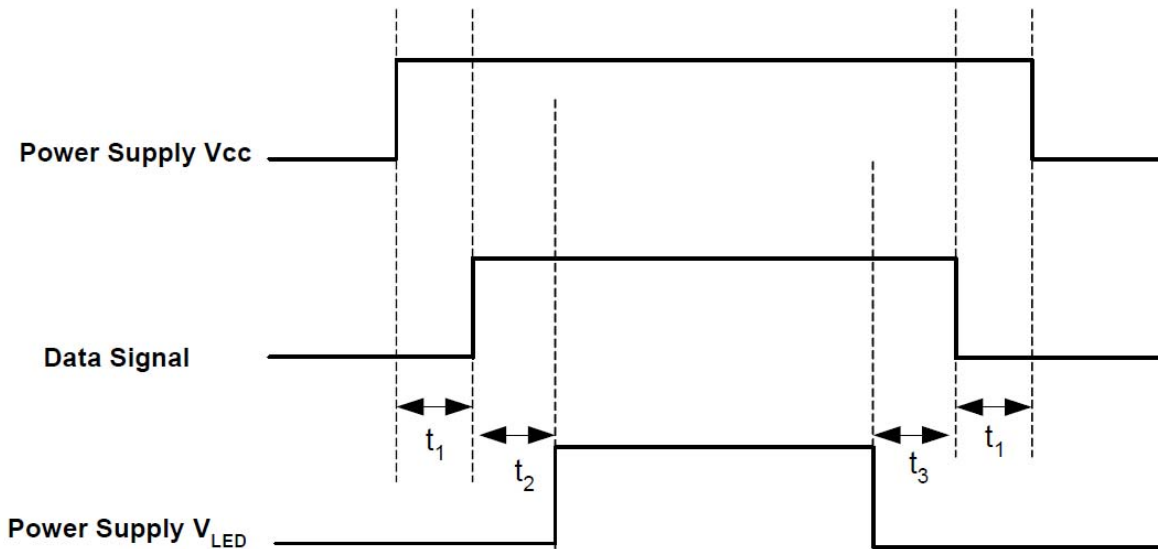

$t_1 > 50 \text{ mSec}$

$t_2 \cong 200 \text{ mSec}$

$t_3 \cong 200 \text{ mSec}$

Note: Data Signal includes DCLK, DE, HS, VS, R0~ R5, G0~ G5, B0~ B5.

9. Optical Specification

Ta=25°C

Item	Symbol	Condition	Min	Typ.	Max.	Unit	Remark
Contrast Ratio	CR	$\theta=\Phi=0^\circ$	400	500	-		Note1 Note2
Response Time	Ton/ Toff	25°C	-	10	20	ms	Note1 Note3
			-	15	30		
View Angles	θT	$CR \geq 10$	40	50	-	Degree	Note 4
	θB		60	70	-		
	θL		60	70	-		
	θR		60	70	-		
Chromaticity	White	Brightness is on	x	0.26	0.31	0.36	Note5, Note1
			y	0.28	0.33	0.38	
Luminance	L		250	300	-	cd/m ²	Note1 Note6
Uniformity	U		70	75	-	%	Note1 Note7

Test condition: VCC=3.3V, VLED=5.0V. The ambient temperature is 25°C.

Note 1: Definition of optical measurement system.

Temperature = 25°C (±3°C)

LED back-light: ON, Environment brightness < 150 lx

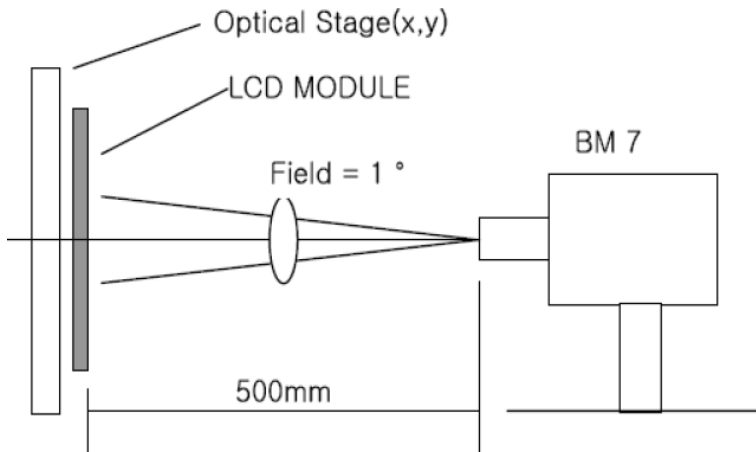

Note 2: Contrast ratio is defined as follow:

$$\text{Contrast Ratio} = \frac{\text{Surface Luminance with all white pixels}}{\text{Surface Luminance with all black pixels}}$$

Note 3: Response time is defined as follow:

Response time is the time required for the display to transition from black to white (Rise Time, Tr) and from white to black(Decay Time, Tf).

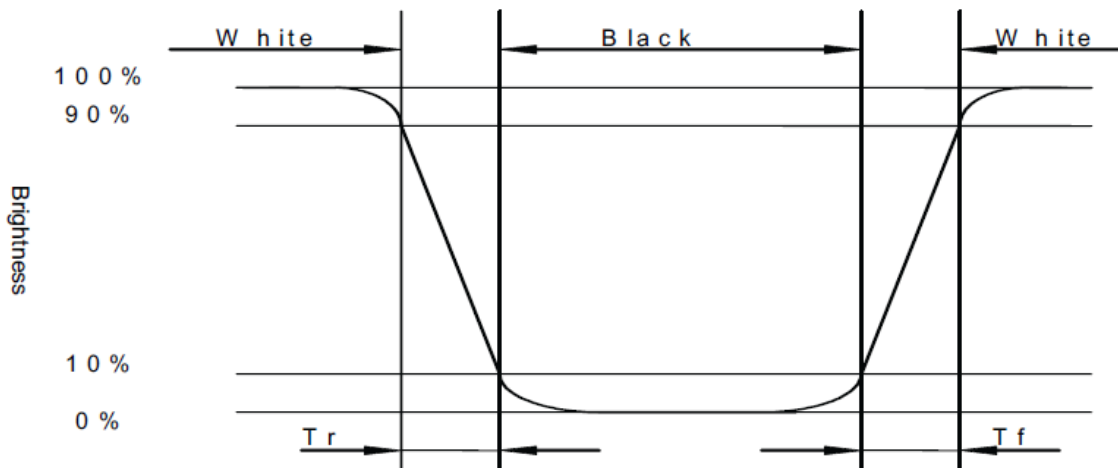

Note 4: Viewing angle range is defined as follow:

Viewing angle is measured at the center point of the LCD.

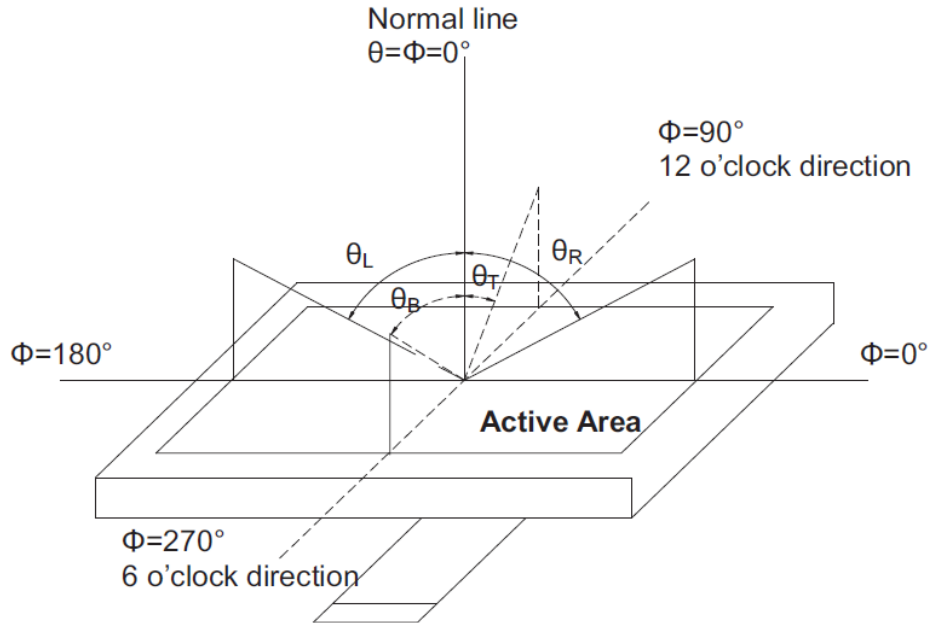

Note 5: Color chromaticity is defined as follow: (CIE1931)

Color coordinates measured at center point of LCD.

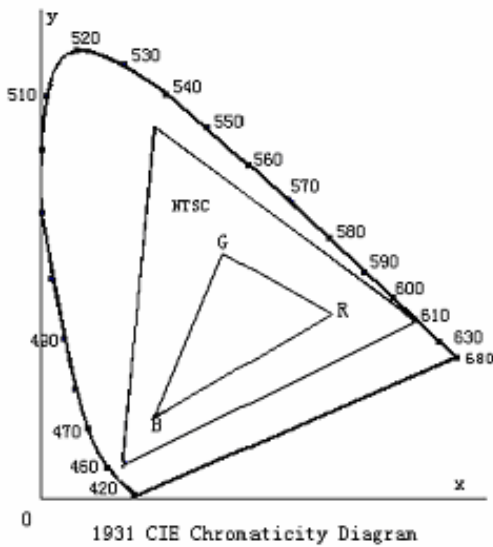

$$S = \frac{\text{area of RGB triangle}}{\text{area of NTSC triangle}} \times 100\%$$

Note 6: Luminance is defined as follow:

Luminance is defined as the brightness of all pixels “White” at the center of display area on optimum contrast.

Note 7: Luminance Uniformity is defined as follow:

Active area is divided into 9 measuring areas (Refer Fig. 2). Every measuring point is placed at the center of each measuring area.

$$\text{Uniformity (U)} = \frac{\text{Minimum Luminance(brightness) in 9 points}}{\text{Maximum Luminance(brightness) in 9 points}}$$

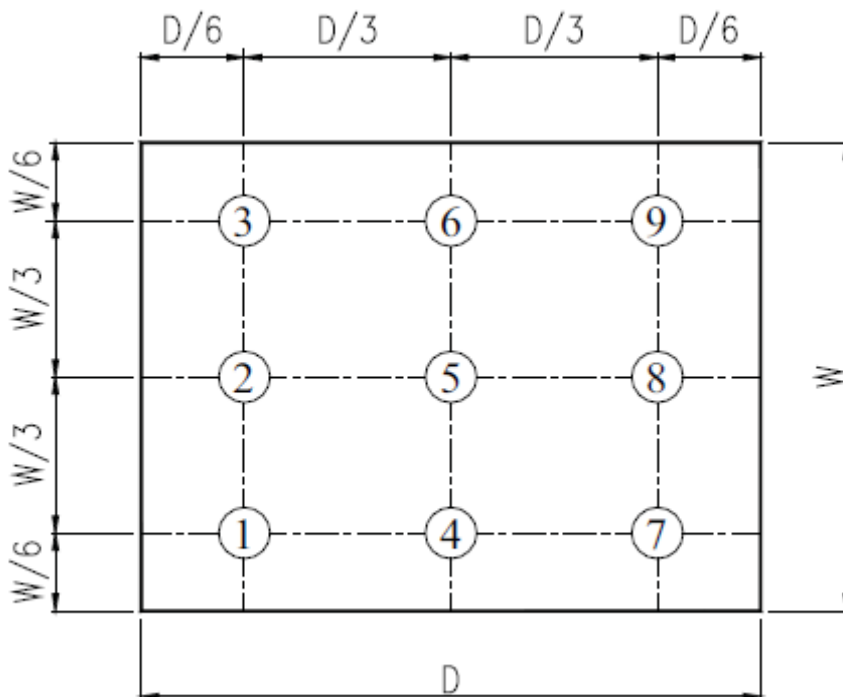

Fig. 2 Definition of uniformity

10. Environmental / Reliability Tests

No	Test Item	Condition	Judgment criteria
1	High Temp Operation	Ts=+70°C, 240hrs	Per table in below
2	Low Temp Operation	Ta=-20°C, 240hrs	Per table in below
3	High Temp Storage	Ta=+80°C, 240hrs	Per table in below
4	Low Temp Storage	Ta=-30°C, 240hrs	Per table in below
5	High Temp & High Humidity Storage	Ta=+40°C, 90% RH max 240 hours	Per table in below (polarizer discoloration is excluded)
6	Thermal Shock (Non-operation)	-30°C 30 min~+80°C 30 min, Change time:5min, 100 Cycles	Per table in below
7	ESD (Operation)	C=150pF, R=330Ω · 5points/panel Air:±8KV, 5times; Contact:±4KV, 5 times;	Per table in below
8	Vibration (Non-operation)	Frequency range:10~55Hz, Stroke:1.5mm Sweep:10Hz~55Hz~10Hz 2 hours for each direction of X.Y.Z.	Per table in below
9	Shock (Non-operation)	100G 6ms, ±X,±Y,±Z 3times, for each direction	Per table in below
10	Package Drop Test	Height:60 cm, 1 corner, 3 edges, 6 surfaces	Per table in below

INSPECTION	CRITERION(after test)
Appearance	No Crack on the FPC, on the LCD Panel
Alignment of LCD Panel	No Bubbles in the LCD Panel No other Defects of Alignment in Active area
Electrical current	Within device specifications
Function / Display	No Broken Circuit, No Short Circuit or No Black line No Other Defects of Display

11. Precautions for Use of LCD Modules

11.1 Safety

The liquid crystal in the LCD is poisonous. Do not put it in your mouth. If the liquid crystal touches your skin or clothes, wash it off immediately using soap and water.

11.2 Handling

- A. The LCD and touch panel is made of plate glass. Do not subject the panel to mechanical shock or to excessive force on its surface.
- B. Do not handle the product by holding the flexible pattern portion in order to assure the reliability
- C. Transparency is an important factor for the touch panel. Please wear clear finger sacks, gloves and mask to protect the touch panel from finger print or stain and also hold the portion outside the view area when handling the touch panel.
- D. Provide a space so that the panel does not come into contact with other components.
- E. To protect the product from external force, put a covering lens (acrylic board or similar board) and keep an appropriate gap between them.
- F. Transparent electrodes may be disconnected if the panel is used under environmental conditions where dew condensation occurs.
- G. Property of semiconductor devices may be affected when they are exposed to light, possibly resulting in IC malfunctions.
- H. To prevent such IC malfunctions, your design and mounting layout shall be done in the way that the IC is not exposed to light in actual use.

11.3 Static Electricity

- A. Ground soldering iron tips, tools and testers when they are in operation.
- B. Ground your body when handling the products.
- C. Power on the LCD module before applying the voltage to the input terminals.
- D. Do not apply voltage which exceeds the absolute maximum rating.
- E. Store the products in an anti-electrostatic bag or container.

11.4 Storage

- A. Store the products in a dark place at $+25^{\circ}\text{C} \pm 10^{\circ}\text{C}$ with low humidity (40% RH to 60% RH). Don't expose to sunlight or fluorescent light.
- B. Storage in a clean environment, free from dust, active gas, and solvent.

11.5 Cleaning

- A. Do not wipe the touch panel with dry cloth, as it may cause scratch.
- B. Wipe off the stain on the product by using soft cloth moistened with ethanol. Do not allow ethanol to get in between the upper film and the bottom glass. It may cause peeling issue or defective operation. Do not use any organic solvent or detergent other than ethanol.

11.6 Cautions for installing and assembling

Bezel edge must be positioned in the area between the Active area and View area. The bezel may press the touch screen and cause activation if the edge touches the active area. A gap of approximately 0.5mm is needed between the bezel and the top electrode. It may cause unexpected activation if the gap is too narrow. There is a tolerance of 0.2 to 0.3mm for the outside dimensions of the touch panel and tail. A gap must be made to absorb the tolerance in the case and connector.

