



ASI-T-570GA4A2/D

Item	Contents	Unit
Size	5.7	inch
Resolution	640(RGB) x 480	/
Technology type	a-Si TFT	/
Pixel pitch	0.18x0.18	mm
Pixel Configuration	R.G.B. Vertical Stripe	
Outline Dimension (W x H x D)	127x 98.43x8.75	mm
Active Area	115.2 x 86.4	mm
Display Mode	Transmissive, Normally white	/
Viewing Direction	12 O'clock	/
Backlight Type	LED	/



ASI-T-570GA4A2/D

Record of Revision

Date	Revision No.	Summary
2012-06-08	1.0	Rev 1.0 was issued



ASI-T-570GA4A2/D

1. Scope

This data sheet is to introduce the specification of ASI-T-570GA4A2/D active matrix TFT module. It is composed of a color TFT-LCD panel, driver ICs, FPC, Capacitive touch panel and a backlight unit. The 5.7" display area contains 640(RGB) x 480 pixels.

2. Application

Digital equipments which need color display, such as P.O.S, medical equipments and industrial equipments..

3. General Information

Item	Contents	Unit
Size	5.7	inch
Resolution	640(RGB) x 480	/
Technology type	a-Si TFT	/
Pixel pitch	0.18x0.18	mm
Pixel Configuration	R.G.B. Vertical Stripe	
Outline Dimension (W x H x D)	127x 98.43x8.75	mm
Active Area	115.2 x 86.4	mm
Display Mode	Transmissive, Normally white	/
Viewing Direction	12 O'clock	/
Backlight Type	LED	/

4. Outline Drawing

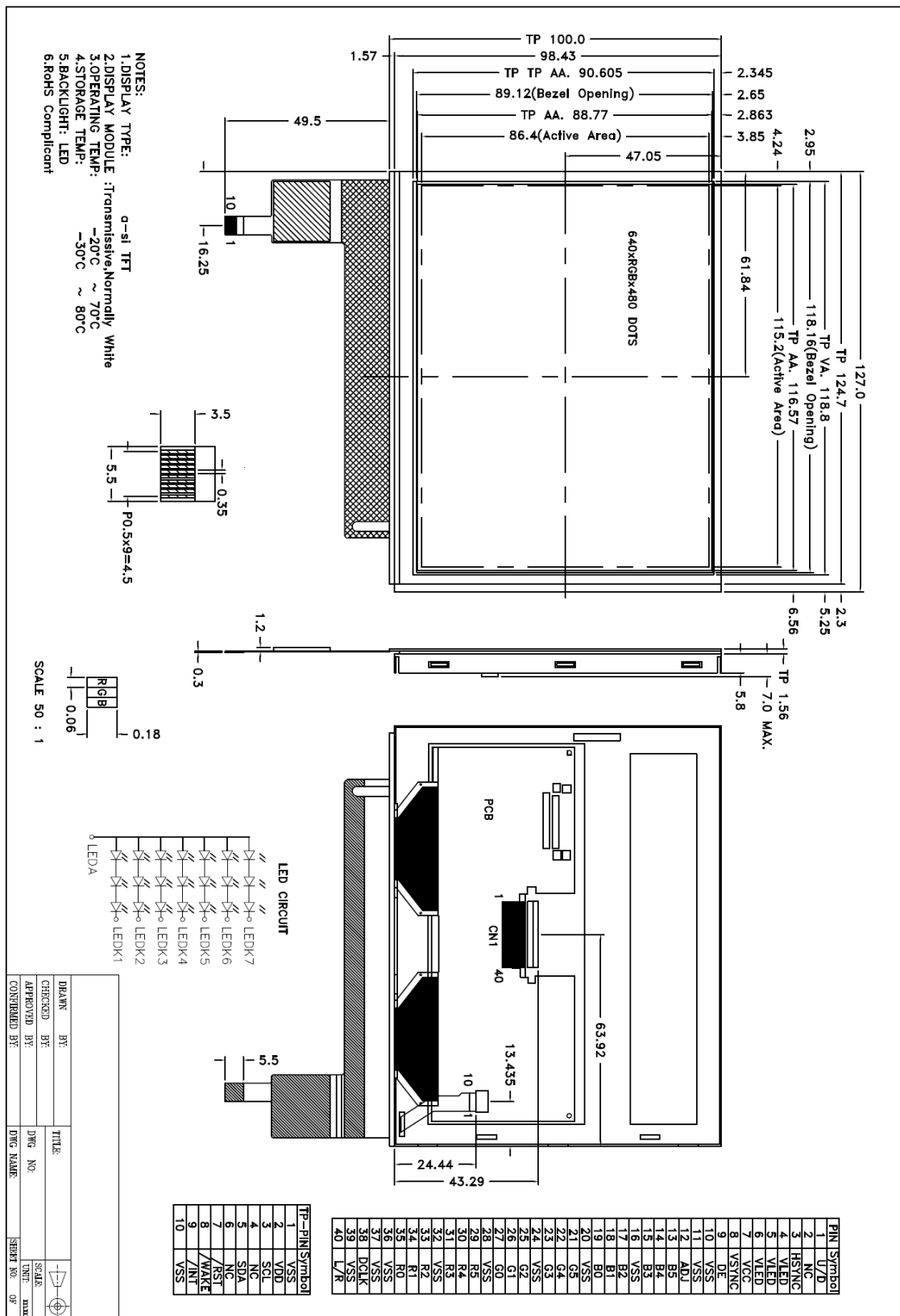



5. Interface signals

5.1 CN1 pin assignment

No	Symbol	Description	Remarks
1	U/D	Up or Down Display Control	
2	NC	No Connection	
3	Hsync	Horizontal SYNC.	
4	VLED	Power Supply for LED Driver circuit	
5	VLED	Power Supply for LED Driver circuit	
6	VLED	Power Supply for LED Driver circuit	
7	VCC	Power Supply for LCD	
8	Vsync	Vertical SYNC.	
9	DE	Data Enable	
10	VSS	Power Ground	
11	VSS	Power Ground	
12	ADJ	Brightness control for LED B/L	
13	B5	Blue Data 5 (MSB)	
14	B4	Blue Data 4	
15	B3	Blue Data 3	
16	VSS	Power Ground	
17	B2	Blue Data 2	
18	B1	Blue Data 1	
19	B0	Blue Data 0 (LSB)	
20	VSS	Power Ground	
21	G5	Green Data 5 (MSB)	
22	G4	Green Data 4	
23	G3	Green Data 3	
24	VSS	Power Ground	
25	G2	Green Data 2	
26	G1	Green Data 1	
27	G0	Green Data 0 (LSB)	
28	VSS	Power Ground	
29	R5	Red Data 5 (MSB)	
30	R4	Red Data 4	
31	R3	Red Data 3	
32	VSS	Power Ground	
33	R2	Red Data 2	
34	R1	Red Data 1	
35	R0	Red Data 0	
36	VSS	Power Ground	
37	VSS	Power Ground	
38	DCLK	Clock Signals ; Latch Data at the Falling Edge	
39	VSS	Power Ground	
40	L/R	Left or Right Display Control	

Note :

- 1) ADJ is brightness control Pin. The larger of the pulse duty is, the higher of the brightness.
- 2) ADJ signal is 0~3.3V.Operation frequency is 20KHz
- 3) VSS PIN must be grounding, can not be floating.



4) U/D and L/R control Function

L/R	U/D	Function
1	0	Normally display
0	0	Left and Right opposite
1	1	Up and Down opposite
0	1	Left and Right opposite, Up and Down opposite

5) If DE signal is fixed low, SYNC mode is used. Otherwise, DE mode is used.

5.2 CN2 CTP signal interface

No	Symbol	Description
1	VSS	GROUND
2	VDD	POWER SUPPLY VOLTAGE
3	SCL (SSEL)	I2C CLOCK INPUT (ACTIVE LOW SELECT SIGNAL)
4	NC (SCK)	NC (SERIAL DATA CLOCK)
5	SDA (MOSI)	I2C DATA INPUT AND OUTPUT (DATA LINE FROM MASTER TO SLAVE)
6	NC (MISO)	NC (DATA LINE FROM SLAVE TO MASTER)
7	/RST	EXTERNAL RESET, LOW IS ACTIVE
8	/WAKE	EXTERNAL INTERRUPT FROM THE HOST
9	/INT	EXTERNAL INTERRUPT TO THE HOST
10	VSS	GROUND

Matching Connector type: KYOCERA : 04 6240 010 SERIES

6. Absolute maximum Ratings

6.1. Electrical Absolute max. ratings

Parameter	Symbol	MIN	MAX	Unit	Remark
Power Supply Voltage	VCC	-0.3	5.0	V	
Logic supply Voltage	Vi	-0.3	Vcc+0.3	V	

6.2. Environment Conditions

Item	Symbol	MIN	MAX	Unit	Remark
Operating Temperature	TOPR	-20	70	°C	
Storage Temperature	TSTG	-30	80	°C	



ASI-T-570GA4A2/D

7. Electrical Specifications

7.1 Electrical characteristics

GND=0V, Ta=25°C

Item	Symbol	MIN	TYP	MAX	Unit	Remark
Power Supply voltage	VCC	+3.0	+3.3	+3.6	V	
Power Supply Current	ICC		111	140	mA	V _{CC} =3.3V
Ripple voltage	VRF		-	100	mV P-P	
Input Signal Voltage	VIL	0	--	0.3VCC	V	
	VIH	0.7VCC	--	VCC	V	
ADJ input voltage	VIH	3.0	-	3.3	V	
	VIL	0	-	0.3	V	
ADJ frequency		19K	20K	21K	Hz	

7.2 LED Backlight

Ta=25°C

Item	Symbol	MIN	TYP	MAX	Unit	Remark
Forward Current	IF	-	333	400	mA	V _{LED} =5.0V
Forward Voltage	V _{LED}	4.5	5	5.5	V	
Led life time	--		50000		Hr	Note

Note : The "LED dice life time" is defined as the brightness decrease to 50% original brightness that the ambient temperature is 22°C and LED dice current=20mA.

7.3 Schematic of LCD module system

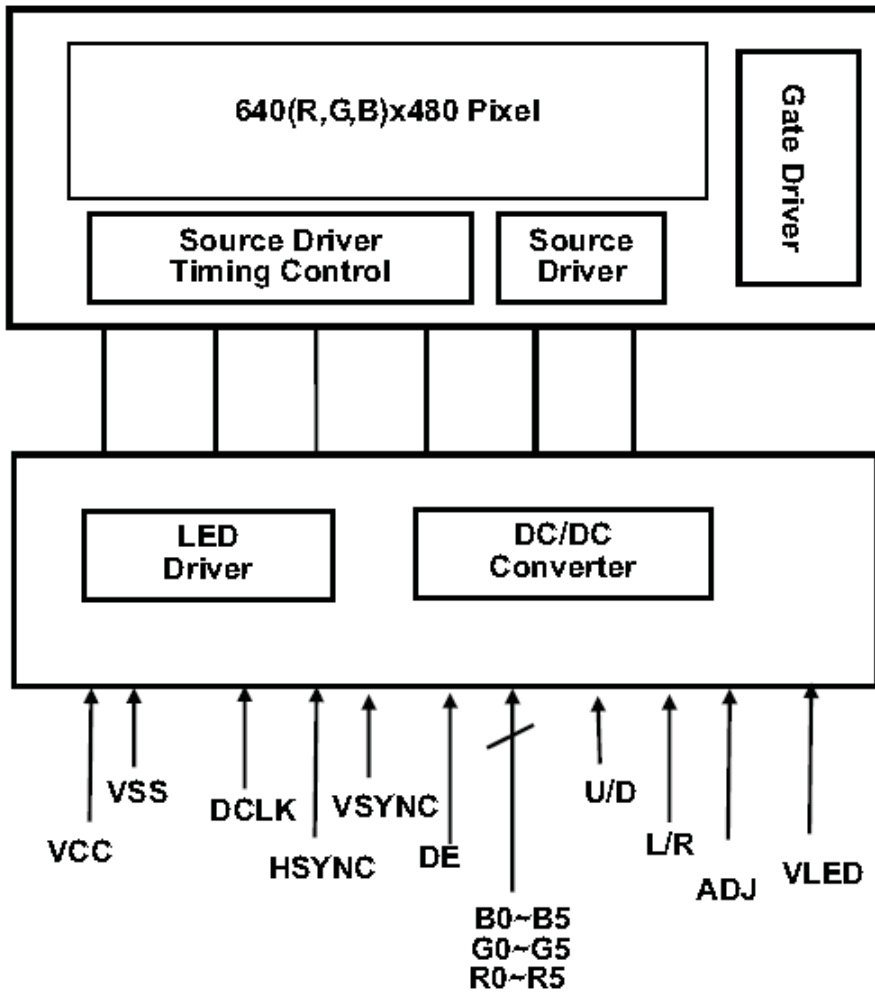

8. Command/AC Timing

8.1 DE mode Input signal characteristics

Signal	Parameter	Symbol	Min	TYP	Max	Unit
DCLK	Period	tCLK	33	40	43	ns
	Frequency	fCLK	23	25	30	MHz
	Low Level Width	tWCL	6	-	-	ns
	High Level Width	tWCH	6	-	-	ns
	Rise, Fall Time	tCLKr,tCLKf	-	-	3	ns
	Duty (1)	-	0.45	0.5	0.55	-
DE (Data Enable)	Setup Time	tDES	5	-	-	ns
	Hold Time	tDEH	10	-	-	ns
	Rise, Fall Time	tDEr,tDEf	-	-	16	ns
	Horizontal Period	tHP	750	800	900	tCLK
	Horizontal Valid	tHV	640	640	640	tCLK
	Horizontal Blank	tHBK	110	160	260	tCLK
	Vertical Period	tVP	515	525	560	tHP
	Vertical Valid	tW	480	480	480	tHP
	Vertical Blank	tVBK	35	45	80	tHP
Vertical Frequency	f v	55	60	65	Hz	
Data R,G,B	Setup Time	tDS	5	-	-	ns
	Hold Time	tDH	10	-	-	ns
	Rise, Fall Time	tDr,tDf	-	-	3	ns

Nc

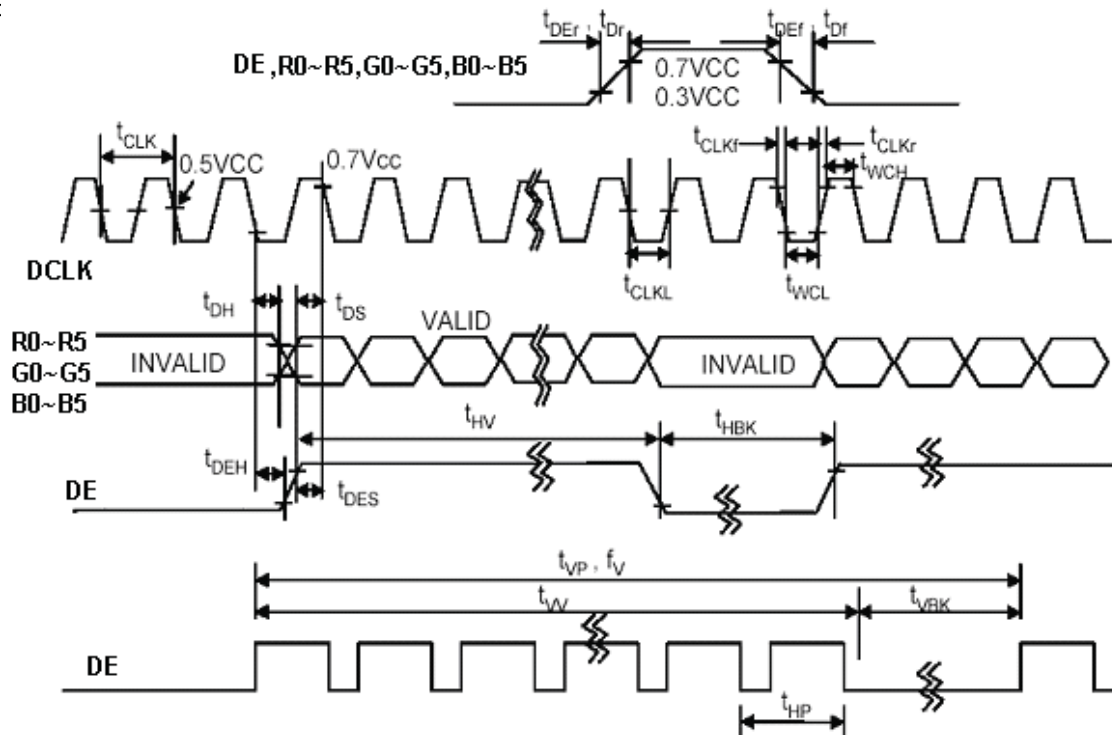

8.3 SYNC mode Input signal characteristics

Parameter	Symbol	MIN.	TYP.	MAX.	Unit
Clock Period	tCLK	33	40	43	ns
Clock Frequency	fCLK	23	25	30	MHz
Clock Low Level Width	tWCL	6	-	-	ns
Clock High Level Width	tWCH	6	-	-	ns
Clock Rise, Fall Time	tCLKr,tCLKf	-	-	3	ns
HSYNC Period	tHP	750	800	900	tCLK
HSYNC Pulse Width	tHW	5	30	-	tCLK
HSYNC Front Porch	tHFP	1	16	116	tCLK
HSYNC Back Porch	tHBP	1	114	139	tCLK
HSYNC Width + Back Porch	tHW+ tHBP	144	144	144	tCLK
Horizontal Blank	tHBK	1	160	260	tCLK
Horizontal Valid	tHV	640	640	640	tCLK
VSYNC Period	tVP	515	525	560	tHP
VSYNC Pulse Width	tVW	1	3	5	tHP
VSYNC Front Porch	tVFP	1	10	45	tHP
VSYNC Back Porch	tVBP	30	32	34	tHP
VSYNC Width + Back Porch	tVW+ tVBP	35	35	35	tCLK
Vertical Blank	tVBK	35	45	80	tHP
Valid data Width	tW	480	480	480	tHP
Data Setup Time	tDS	5	-	-	ns
Data Hold Time	tDH	10	-	-	ns

Note: tHBK = tHFP + tHW + Thbp

8.4 SYNC mode timing waveform

8.4.1 Input vertical timing

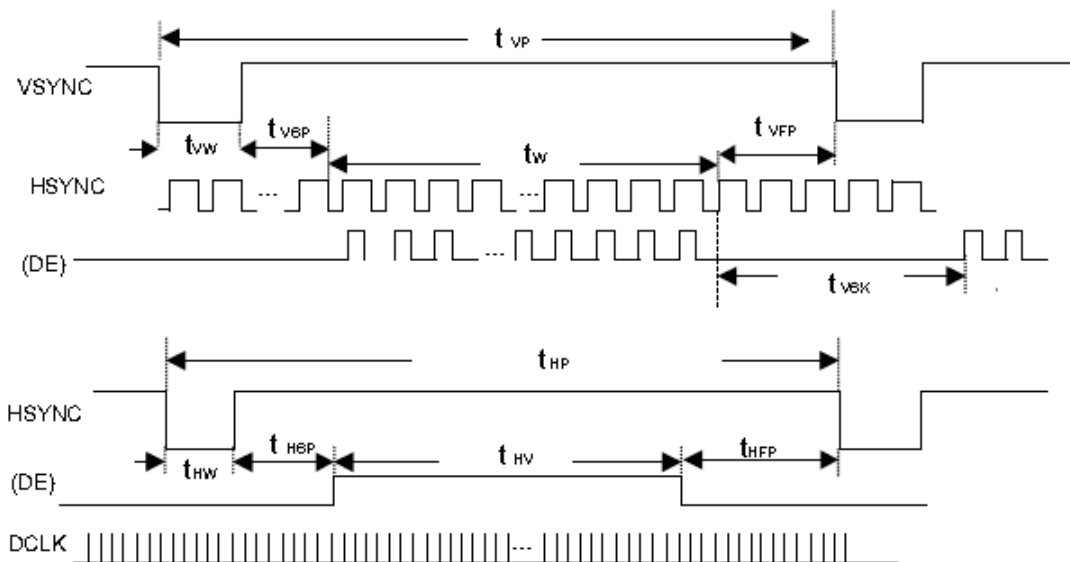

Note : If SYNC mode is used, please fix DE signal to low, DE timing waveform is for reference only.

8.4.2 Input horizontal timing

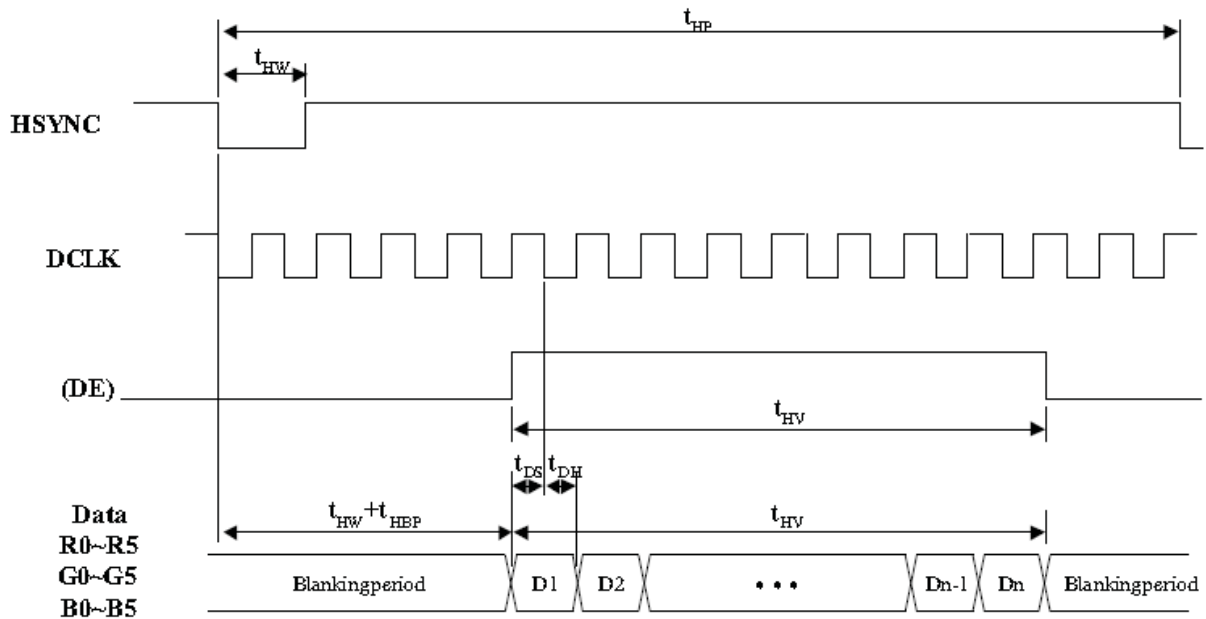

Note : If SYNC mode is used, please fix DE signal to low, DE timing waveform is for reference only.



ASI-T-570GA4A2/D

8.5 color data assignment

COLOR	INPUT	R DATA						G DATA						B DATA					
	DATA	R5	R4	R3	R2	R1	R0	G5	G4	G3	G2	G1	G0	B5	B4	B3	B2	B1	B0
		MSB					LSB	MSB					LSB	MSB					LSB
BASIC COLOR	BLACK	0	0	0	0	0	0	0	0	0	0	0	0	0	0	0	0	0	0
	RED(63)	1	1	1	1	1	1	0	0	0	0	0	0	0	0	0	0	0	0
	GREEN(63)	0	0	0	0	0	0	1	1	1	1	1	1	0	0	0	0	0	0
	BLUE(63)	0	0	0	0	0	0	0	0	0	0	0	0	1	1	1	1	1	1
	CYAN	0	0	0	0	0	0	1	1	1	1	1	1	1	1	1	1	1	1
	MAGENTA	1	1	1	1	1	1	0	0	0	0	0	0	1	1	1	1	1	1
	YELLOW	1	1	1	1	1	1	1	1	1	1	1	1	0	0	0	0	0	0
	WHITE	1	1	1	1	1	1	1	1	1	1	1	1	1	1	1	1	1	1
RED	RED(0)	0	0	0	0	0	0	0	0	0	0	0	0	0	0	0	0	0	0
	RED(1)	0	0	0	0	0	1	0	0	0	0	0	0	0	0	0	0	0	0
	RED(2)	0	0	0	0	1	0	0	0	0	0	0	0	0	0	0	0	0	0
	:	:	:	:	:	:	:	:	:	:	:	:	:	:	:	:	:	:	:
	:	:	:	:	:	:	:	:	:	:	:	:	:	:	:	:	:	:	:
	RED(62)	1	1	1	1	1	0	0	0	0	0	0	0	0	0	0	0	0	0
	RED(63)	1	1	1	1	1	1	0	0	0	0	0	0	0	0	0	0	0	0
GREEN	GREEN(0)	0	0	0	0	0	0	0	0	0	0	0	0	0	0	0	0	0	0
	GREEN(1)	0	0	0	0	0	0	0	0	0	0	1	0	0	0	0	0	0	0
	GREEN(2)	0	0	0	0	0	0	0	0	0	0	1	0	0	0	0	0	0	0
	:	:	:	:	:	:	:	:	:	:	:	:	:	:	:	:	:	:	:
	:	:	:	:	:	:	:	:	:	:	:	:	:	:	:	:	:	:	:
	GREEN(62)	0	0	0	0	0	0	1	1	1	1	1	0	0	0	0	0	0	0
	GREEN(63)	0	0	0	0	0	0	1	1	1	1	1	1	0	0	0	0	0	0
BLUE	BLUE(0)	0	0	0	0	0	0	0	0	0	0	0	0	0	0	0	0	0	0
	BLUE(1)	0	0	0	0	0	0	0	0	0	0	0	0	0	0	0	0	0	1
	BLUE(2)	0	0	0	0	0	0	0	0	0	0	0	0	0	0	0	0	1	0
	:	:	:	:	:	:	:	:	:	:	:	:	:	:	:	:	:	:	:
	:	:	:	:	:	:	:	:	:	:	:	:	:	:	:	:	:	:	:
	BLUE(62)	0	0	0	0	0	0	0	0	0	0	0	0	1	1	1	1	1	0
	BLUE(63)	0	0	0	0	0	0	0	0	0	0	0	0	1	1	1	1	1	1

Note : (1) Definition of Gray Scale
 color(n):n is series of Gray Scale
 The more n value is, the bright Gray Scale.

(2)Data:1-High,0-Low

Correspondence between Data and Display Position

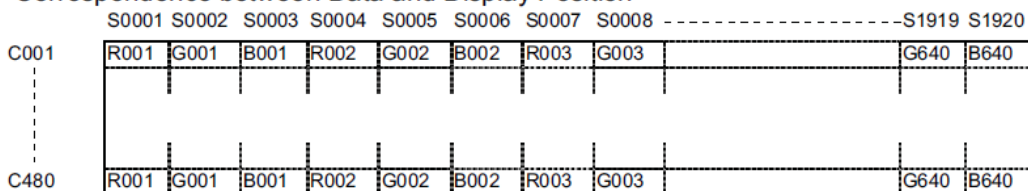

8.6 power signal sequence

Note:

*1) Power Signal sequence:

- t1_10ms : 1 sec_ t5
- 50ms_ t2 : 200ms_ t6
- 0_ t3_ 50ms: 200ms_ t7
- 0_ t4_ 10ms

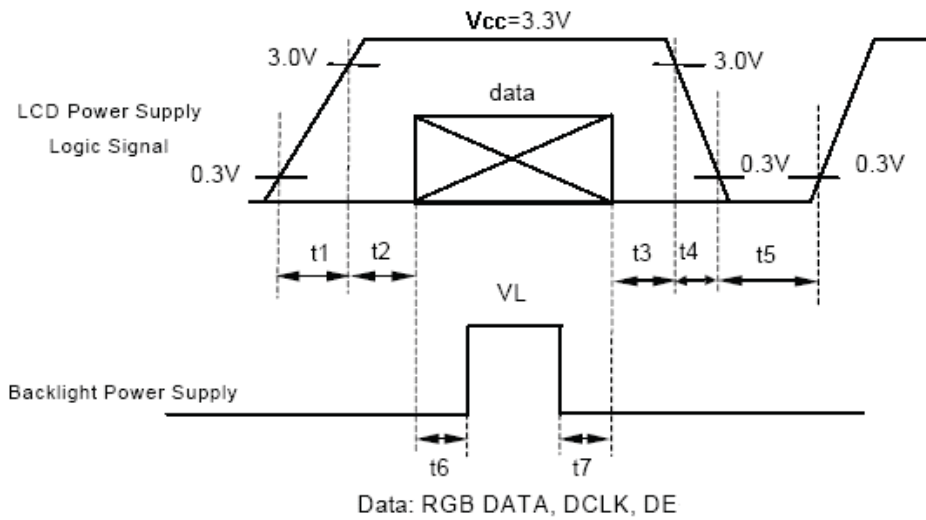

VCC-dip condition:

(1) $2.7\text{ V} \leq V_{CC} < 3.0\text{ V}$, $t_{d10} \leq 10\text{ ms}$.

(2) $V_{CC} > 3.0\text{ V}$, VCC-dip condition should be the same with VCC-turn-on condition.

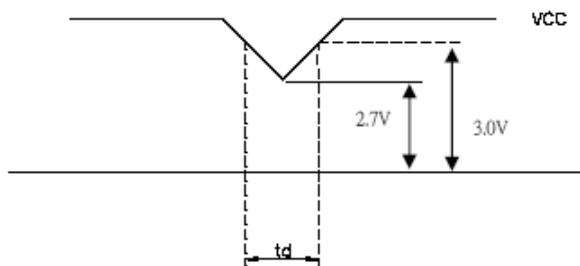



ASI-T-570GA4A2/D

9. Optical Specification

Ta=25°C

Item	Symbol	Condition	Min	Typ.	Max.	Unit	Remark
Contrast Ratio	CR	$\theta=0^\circ$	200	300	-		Note1 Note2
Response Time	Ton/ Toff	25°C	-	40	-	ms	Note1 Note3
View Angles	θT	$CR \geq 10$	50	60	-	Degree	Note 4
	θB		30	40	-		
	θL		60	70	-		
	θR		60	70	-		
Chromaticity	White	Brightness is on	Typ-0.05	0.309	Typ+0.05		Note5, Note1
				y			
	Red			x			
				y			
	Green			x			
				y			
	Blue			x			
				y			
Luminance	L		400	450	-	cd/m ²	Note1 Note6
Uniformity	U		70	80	-	%	Note1 Note7

Note 1: Definition of optical measurement system.

Temperature = 25°C (±3°C)

LED back-light: ON, Environment brightness < 150 lx

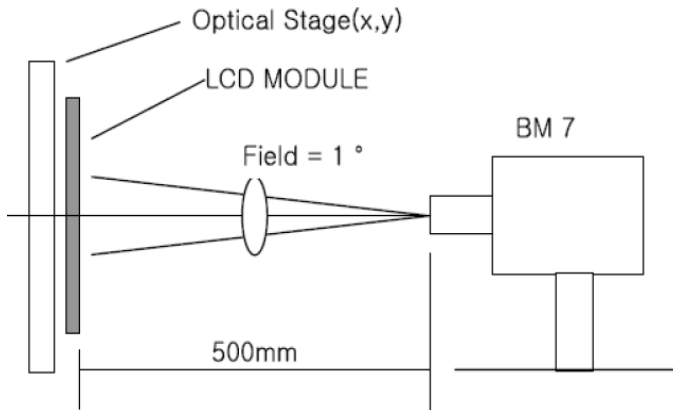

Note 2: Contrast ratio is defined as follow:

$$\text{Contrast Ratio} = \frac{\text{Surface Luminance with all white pixels}}{\text{Surface Luminance with all black pixels}}$$

Note 3: Response time is defined as follow:

Response time is the time required for the display to transition from black to white (Rise Time, Tr) and from white to black(Decay Time, Tf).

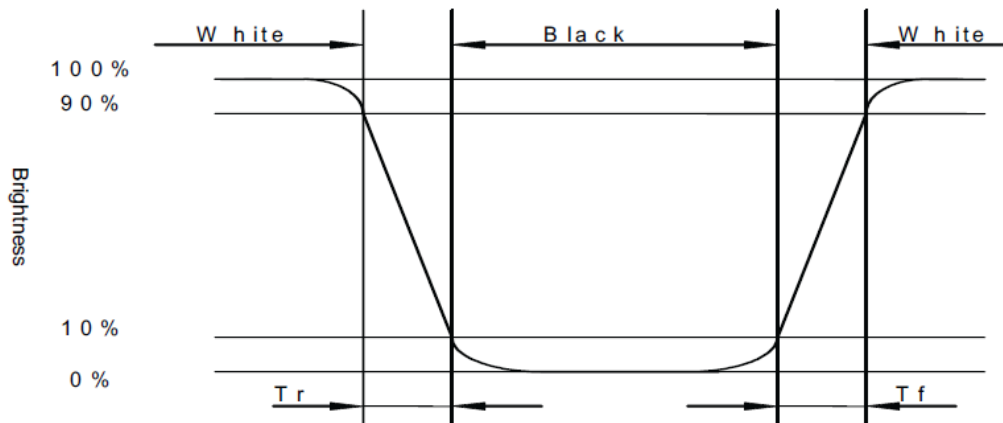

Note 4: Viewing angle range is defined as follow:

Viewing angle is measured at the center point of the LCD.

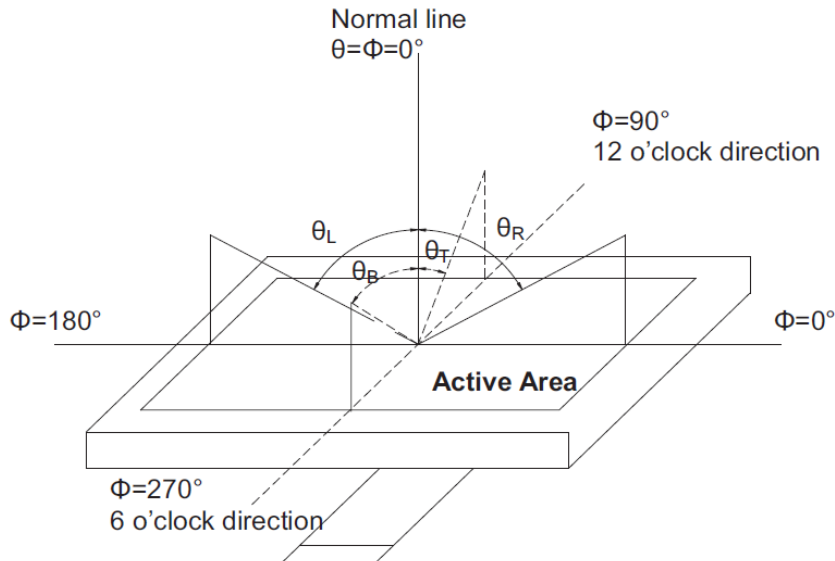

Note 5: Color chromaticity is defined as follow: (CIE1931)

Color coordinates measured at center point of LCD.

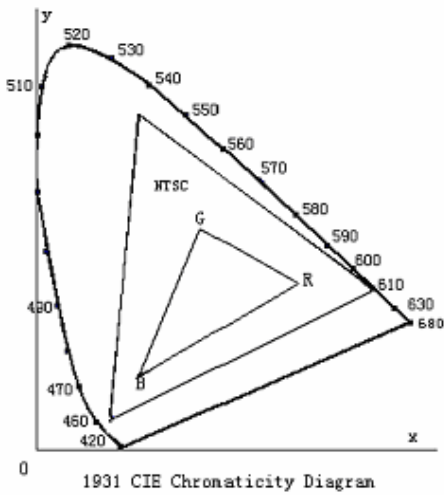

$$S = \frac{\text{area of RGB triangle}}{\text{area of NTSC triangle}} \times 100\%$$

Note 6: Luminance is defined as follow:

Luminance is defined as the brightness of all pixels “White” at the center of display area on optimum contrast.

Note 7: Luminance Uniformity is defined as follow:

Active area is divided into 9 measuring areas (Refer Fig. 2). Every measuring point is placed at the center of each measuring area.

$$\text{Uniformity}(U) = \frac{\text{Minimum Luminance(brightness) in 9 points}}{\text{Maximum Luminance(brightness) in 9 points}}$$

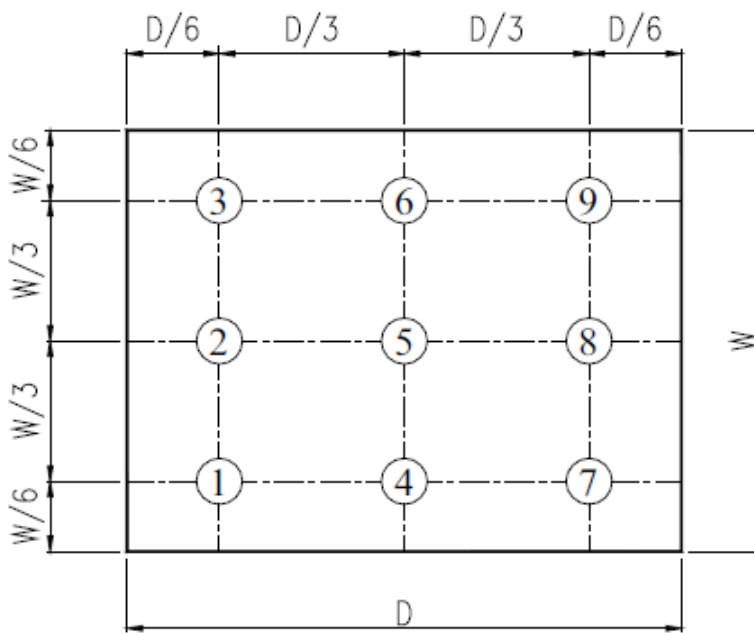

Fig. 2 Definition of uniformity



10. Environmental / Reliability Tests

No	Test Item	Condition	Judgment criteria
1	High Temp Operation	Ts=+70°C, 120hrs	Per table in below
2	Low Temp Operation	Ta=-20°C, 120hrs	Per table in below
3	High Temp Storage	Ta=+80°C, 120hrs	Per table in below
4	Low Temp Storage	Ta=-30°C, 120hrs	Per table in below
5	High Temp & High Humidity Storage	Ta=+60°C, 90% RH 120 hours	Per table in below (polarizer discoloration is excluded)
6	Thermal Shock (Non-operation)	-30°C 30 min~+80°C 30 min, Change time:5min, 10 Cycles	Per table in below
7	ESD (Operation)	C=150pF, R=330Ω , 5points/panel Air:±8KV, 5times; Contact:±4KV, 5 times;	Per table in below
8	Vibration (Non-operation)	Frequency range:10~55Hz, Stroke:1.5mm Sweep:10Hz~55Hz~10Hz 2 hours for each direction of X.Y.Z.	Per table in below
9	Shock (Non-operation)	60G 6ms, ±X,±Y,±Z 3times, for each direction	Per table in below
10	Package Drop Test	Height:80 cm, 1 corner, 3 edges, 6 surfaces	Per table in below

INSPECTION	CRITERION(after test)
Appearance	No Crack on the FPC, on the LCD Panel
Alignment of LCD Panel	No Bubbles in the LCD Panel No other Defects of Alignment in Active area
Electrical current	Within device specifications
Function / Display	No Broken Circuit, No Short Circuit or No Black line No Other Defects of Display

11. Precautions for Use of LCD Modules

11.1 Safety

The liquid crystal in the LCD is poisonous. Do not put it in your mouth. If the liquid crystal touches your skin or clothes, wash it off immediately using soap and water.

11.2 Handling

- A. The LCD and touch panel is made of plate glass. Do not subject the panel to mechanical shock or to excessive force on its surface.
- B. Do not handle the product by holding the flexible pattern portion in order to assure the reliability
- C. Transparency is an important factor for the touch panel. Please wear clear finger sacks, gloves and mask to protect the touch panel from finger print or stain and also hold the portion outside the view area when handling the touch panel.
- D. Provide a space so that the panel does not come into contact with other components.
- E. To protect the product from external force, put a covering lens (acrylic board or similar board) and keep an appropriate gap between them.
- F. Transparent electrodes may be disconnected if the panel is used under environmental conditions where dew condensation occurs.
- G. Property of semiconductor devices may be affected when they are exposed to light, possibly resulting in IC malfunctions.
- H. To prevent such IC malfunctions, your design and mounting layout shall be done in the way that the IC is not exposed to light in actual use.

11.3 Static Electricity

- A. Ground soldering iron tips, tools and testers when they are in operation.
- B. Ground your body when handling the products.
- C. Power on the LCD module before applying the voltage to the input terminals.
- D. Do not apply voltage which exceeds the absolute maximum rating.
- E. Store the products in an anti-electrostatic bag or container.

11.4 Storage

- A. Store the products in a dark place at $+25^{\circ}\text{C} \pm 10^{\circ}\text{C}$ with low humidity (40% RH to 60% RH). Don't expose to sunlight or fluorescent light.
- B. Storage in a clean environment, free from dust, active gas, and solvent.

11.5 Cleaning

- A. Do not wipe the touch panel with dry cloth, as it may cause scratch.
- B. Wipe off the stain on the product by using soft cloth moistened with ethanol. Do not allow ethanol to get in between the upper film and the bottom glass. It may cause peeling issue or defective operation. Do not use any organic solvent or detergent other than ethanol.

11.6 Cautions for installing and assembling

Bezel edge must be positioned in the area between the Active area and View area. The bezel may press the touch screen and cause activation if the edge touches the active area. A gap of approximately 0.5mm is needed between the bezel and the top electrode. It may cause unexpected activation if the gap is too narrow. There is a tolerance of 0.2 to 0.3mm for the outside dimensions of the touch panel and tail. A gap must be made to absorb the tolerance in the case and connector.

