



ASI-T-560GA3RN/D

Item	Contents	Unit
Size	5.6	inch
Resolution	640 (RGB) × 480	/
Interface	Digital	/
Technology type	a-si TFT	/
Pixel pitch	0.0588(W)×0.1764(H)	mm
Pixel Configuration	RGB-stripe	
Outline Dimension	126.5(W)×100(H)×5.7(D)	mm
Active Area	112.896 (W)×84.672(H)	mm
Display Mode	Normally White, Transmissive	/
Viewing Direction	12 O'clock	/
Backlight Type	LED	/



Record of Revision

Date	Revision No.	Summary
2010-05-23	1.0	Rev 1.0 was issued



ASI-T-560GA3RN/D

1. Scope

This data sheet is to introduce the specification of ASI-T-560GA3RN/D active matrix TFT module. It is composed of a color TFT-LCD panel, driver ICs, FPC and a backlight unit. The 5.6" display area contains 640 (RGB) × 480 pixels.

2. Application

Digital equipments which need color display, mobile phone, mobile navigator/video systems.

3. General Information

Item	Contents	Unit
Size	5.6	inch
Resolution	640 (RGB) × 480	/
Interface	Digital	/
Technology type	a-si TFT	/
Pixel pitch	0.0588(W)×0.1764(H)	mm
Pixel Configuration	RGB-stripe	
Outline Dimension	126.5(W)×100(H)×5.7(D)	mm
Active Area	112.896 (W)×84.672(H)	mm
Display Mode	Normally White, Transmissive	/
Viewing Direction	12 O'clock	/
Backlight Type	LED	/

4. Outline Drawing

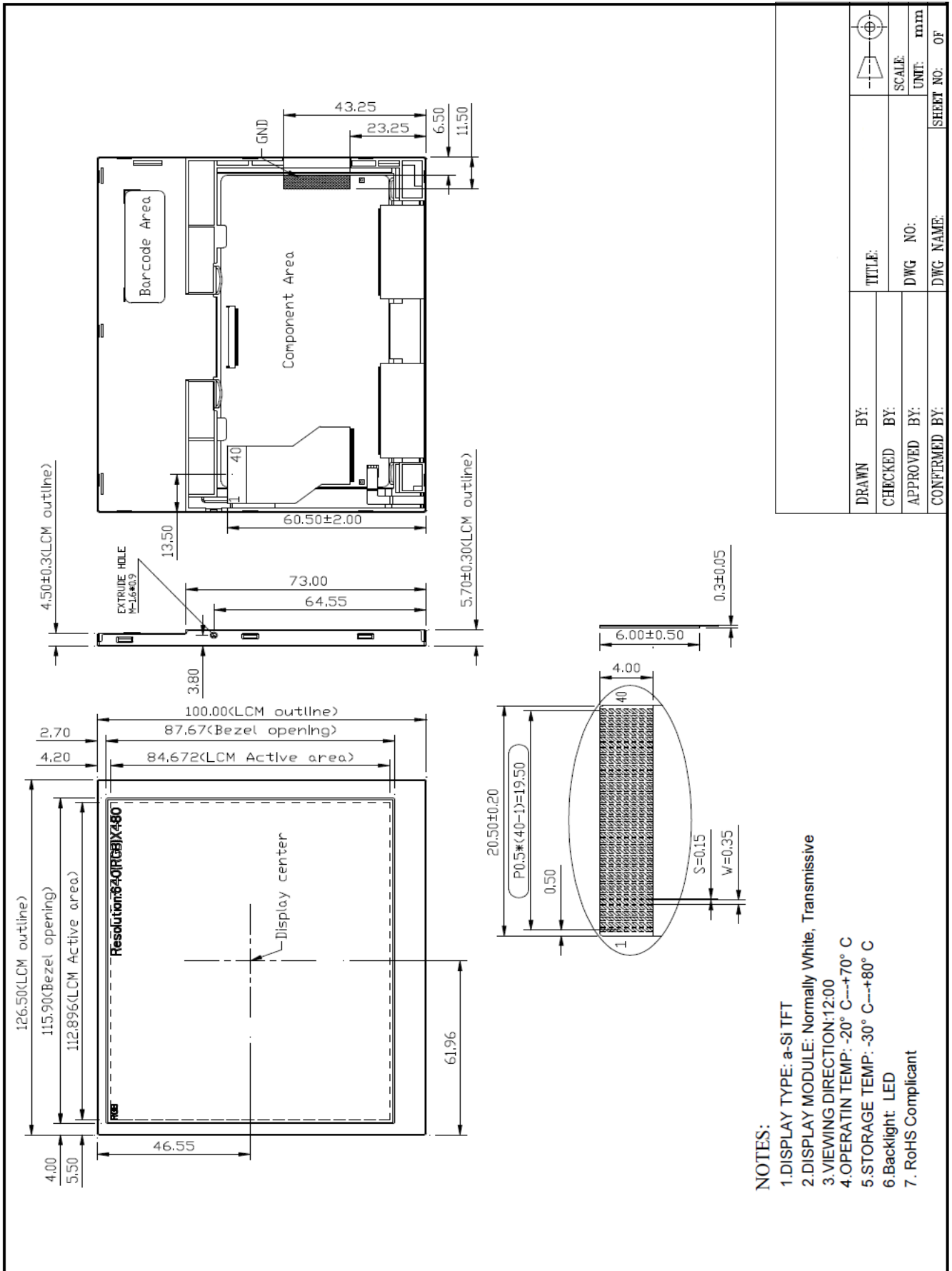

5. Interface signals

Pin No.	Symbol	Function	Remark
1	VLED	Power Voltage for LED circuit	
2	VLED	Power Voltage for LED circuit	
3	ADJ	Adjust the LED brightness with PWM Pulse	Note1,2
4	GLED	Ground for LED circuit	
5	GLED	Ground for LED circuit	
6	VCC	Power Voltage for digital circuit	
7	VCC	Power Voltage for digital circuit	
8	MODE	DE or HV mode control	Note 3
9	DE	Data enable	
10	VS	Vsync signal input	
11	HS	Hsync signal input	
12	GND	Power ground	
13	B5	Blue data input (MSB)	
14	B4	Blue data input	
15	B3	Blue data input	
16	GND	Power ground	
17	B2	Blue data input	
18	B1	Blue data input	
19	B0	Blue data input(LSB)	
20	GND	Power ground	
21	G5	Green data input(MSB)	
22	G4	Green data input	
23	G3	Green data input	
24	GND	Power ground	
25	G2	Green data input	
26	G1	Green data input	
27	G0	Green data input(LSB)	
28	GND	Power ground	
29	R5	Red data input(MSB)	
30	R4	Red data input	
31	R3	Red data input	
32	GND	Power ground	
33	R2	Red data input	
34	R1	Red data input	
35	R0	Red data input(LSB)	
36	GND	Power ground	
37	DCLK	Sample clock	
38	GND	Power ground	
39	L/R	Select left to right scanning direction	Note4,5
40	U/D	Select up or down scanning direction	Note4,5

The recommended connector is FH19-40S -0.5SH manufactured by Hirose.

Note1: Pin.3 is used to adjust brightness

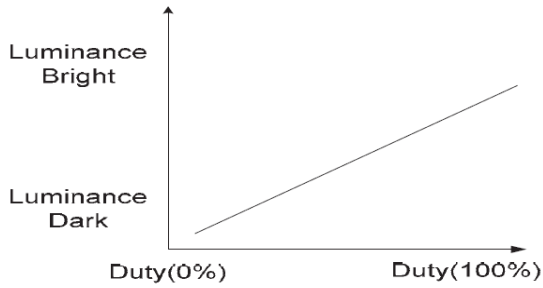

Note 2: ADJ signal=0~3.3V, operation frequency:100~300Hz
F=100~300Hz



Note 3: DE Mode, Mode="H", HS floating and VS floating
HV Mode, Mode="L" and DE floating

Note 4: Selection of scanning mode

Setting of scan control input		Scanning direction
U/D	L/R	
GND	VCC	Up to down, left to right
VCC	GND	Down to up, right to left
GND	GND	Up to down, right to left
VCC	VCC	Down to up, left to right

Note 5: Definition of scanning direction.
Refer to the figure as below:

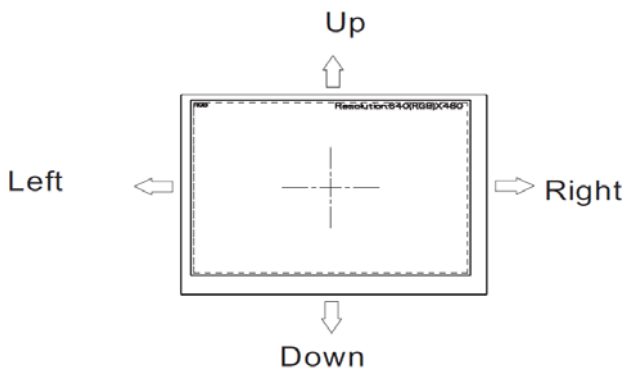



6. Absolute maximum Ratings

6.1. Electrical Absolute max. ratings

Parameter	Symbol	MIN	MAX	Unit	Remark
Supply Voltage	VCC	-0.3	6.5	V	

6.2. Environment Conditions

Item	Symbol	MIN	MAX	Unit	Remark
Operating Temperature	TOPR	-20	70	°C	
Storage Temperature	TSTG	-30	80	°C	

6.3. LED Backlight Absolute max. ratings

Item	Symbol	MIN	MAX	Unit	Remark
Forward Current	I _{LED}	--	25	mA	For each LED
Power voltage	V _{LED}	-0.3	6.5	V	



7. Electrical Specifications

7.1 Electrical characteristics

GND=0V, Ta=25°C

Item	Symbol	MIN	TYP	MAX	Unit	Remark
Supply Voltage	VCC	3.1	3.3	3.5	V	
Input Signal Voltage	VIL	0	--	0.3VCC	V	Note
	VIH	0.7VCC	--	VCC	V	
Current Consumption	ICC	-	200	250	mA	

7.2 LED Backlight

Ta=25°C

Item	Symbol	MIN	TYP	MAX	Unit	Remark
Forward Current	I _{LED}	-	380	450	mA	
Forward Voltage	V _{LED}	4.8	5.0	5.2	V	
Power Consumption	--	-	1.90	-	W	



8. Command/AC Timing

8.1 Timing Conditions
Input/Output Timing

Item	Symbol	Values			Unit.	Remark
		Min.	Typ.	Max.		
PXLCLK clock time	Tclk	33.3	39.7	-	ns	
PXLCLK pulse duty	Tcwh	40	50	60	%	Tclk
DATA set-up time	Tdsu	12	-	-	ns	DATA to PXLCLK
DATA hold time	Tdhd	12	-	-	ns	DATA to PXLCLK
DE setup time	Tesu	12	-	-	ns	DE to PXLCLK
VSYNC setup time	Tvst	12	-	-	ns	
VSYNC hold time	Tvhd	12	-	-	ns	
HSYNC setup time	Thst	12	-	-	ns	
HSYNC hold time	Thhd	12	-	-	ns	
HSYNC period time	Th	22.91	31.76	-	us	
HSYNC width	Thwh	1	-	-	Tclk	
VSYNC width	Twwh	1	-	-	Th	
HSYNC to CLKIN	Thc	-	-	1	Tclk	



DE Mode input Timing Limitation

DE Mode	Values			Unit	Remark
	Min.	Typ.	Max.		
THC	48	160	765	tclk	
THD	640	640	640	tclk	
TH	688	800	1405	tclk	1TH=1line
TVC	6	45	255	line	
TVD	480	480	480	line	
TV	486	525	735	line	1TV=1field

HV Mode input Timing Limitation

HV Mode	Values			Unit	Remark
	Min.	Typ.	Max.		
Thwh	-	10	-	tclk	
Thbp	-	134	-	tclk	
Thfp	-	16	-	tclk	
THD	-	640	-	tclk	
TH	-	800	-	tclk	1TH=1 line
Twh	-	2	-	line	
Tvbp	-	11	-	line	
Tvfp	-	32	-	line	
TVD	-	480	-	line	
TV	-	525	-	line	1TV=1 field

8.2 Timing Diagram

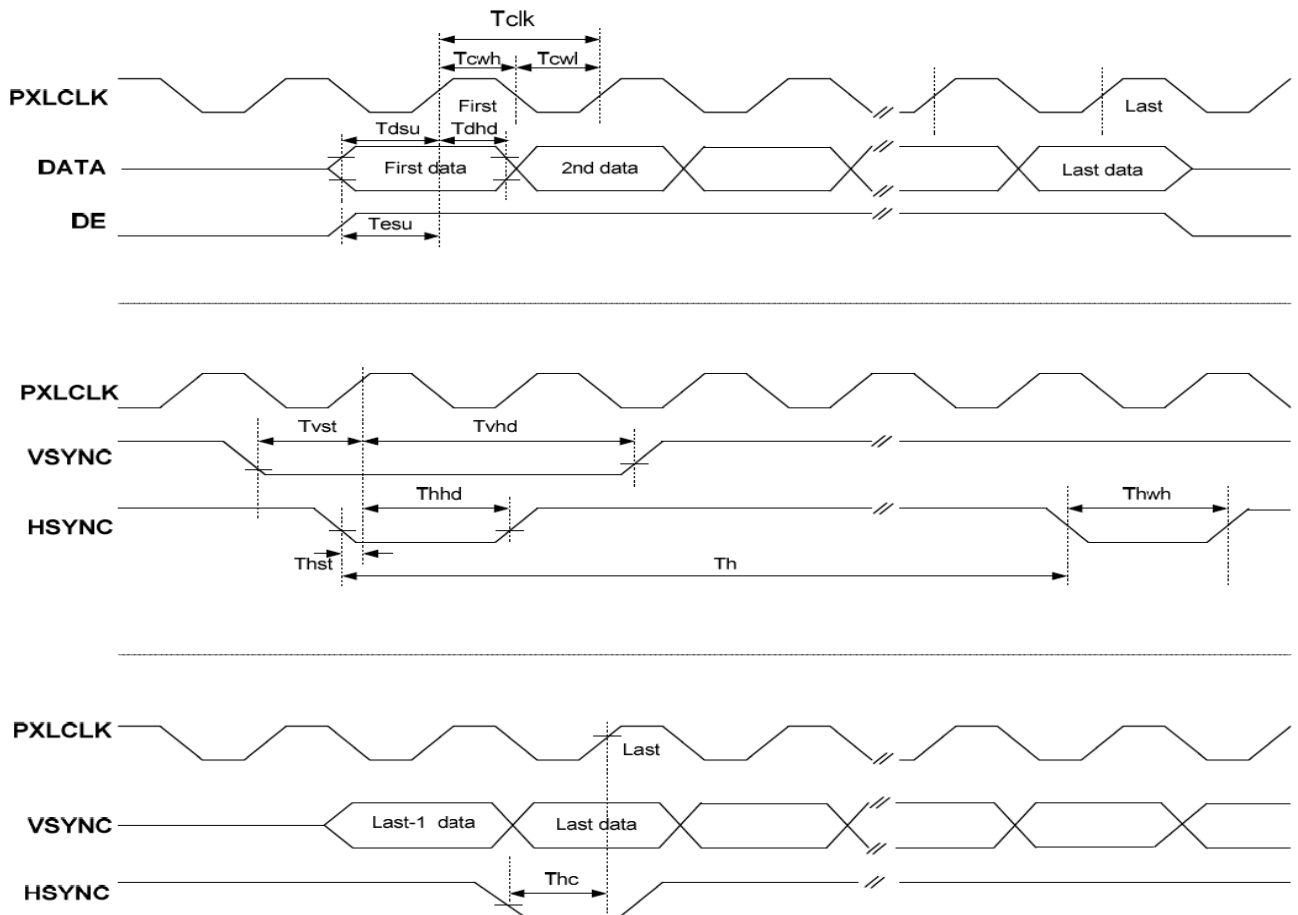

Clock and Data Input Timing Diagram

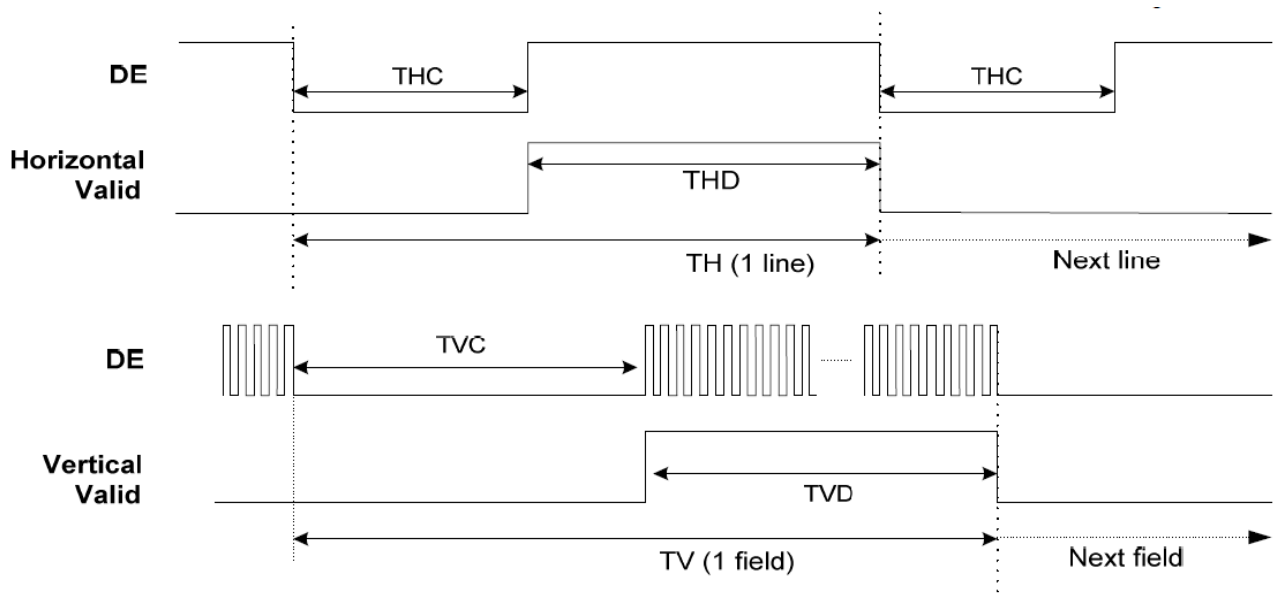

DE Mode Input Timing

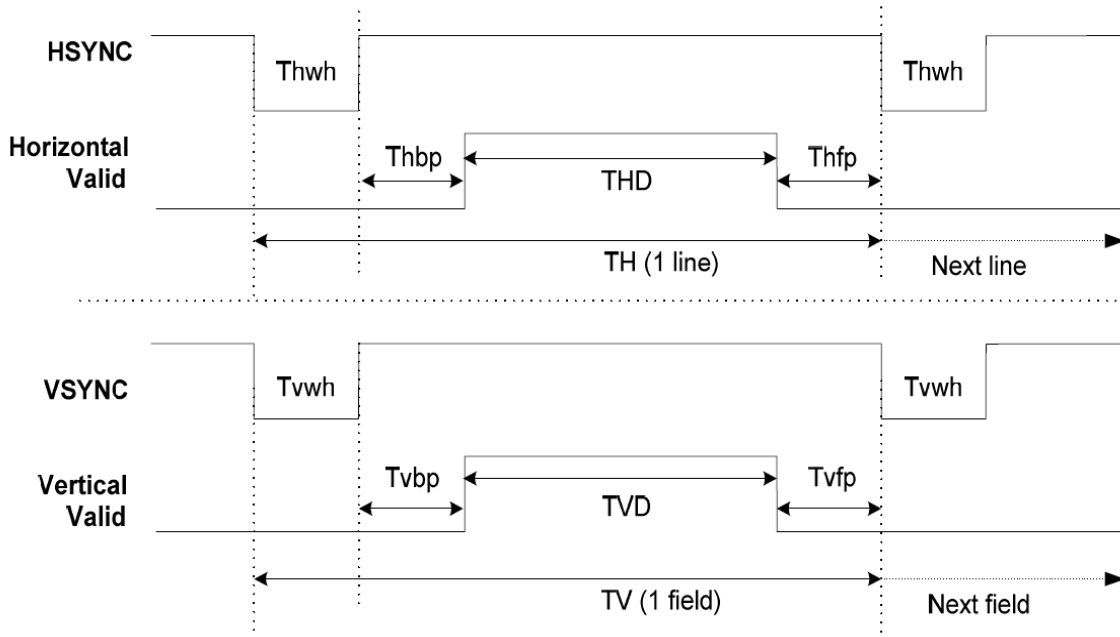

HV Mode Input Timing

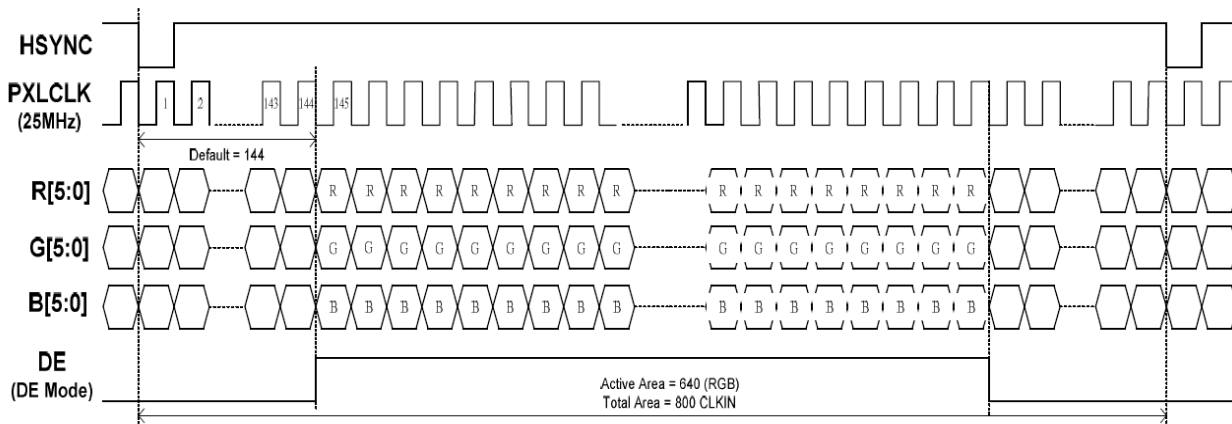
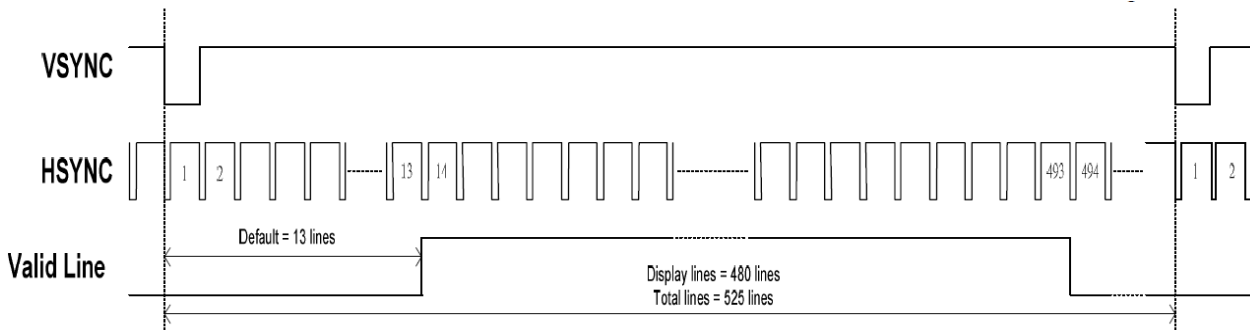

18 bit RGB mode for 640 x (RGB) x 480

8.3 Power Sequence

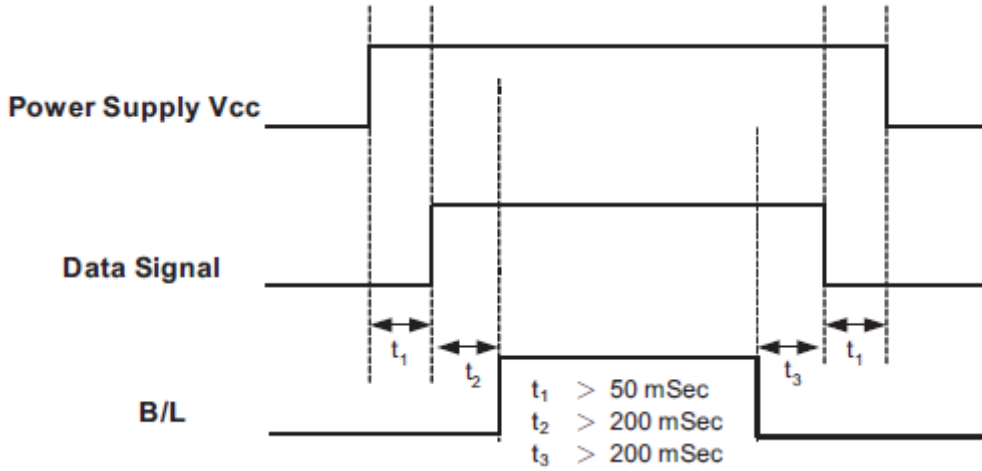

Note: Data includes DE, VS ,HS,B0~B5,G0~G5,R0~R5,DCLK.

9. Optical Specification

Item	Symbol	Condition	Min	Typ.	Max.	Unit	Remark
Contrast Ratio	CR	$\theta=0^\circ$	400	500	-		Note1 Note2
Response Time	Ton	25°C	-	10	20	ms	Note1 Note3
	Toff		-	15	30		
View Angles	θT	$CR \geq 10$	40	50	-	Degree	Note 4
	θB		60	70	-		
	θL		60	70	-		
	θR		60	70	-		
Chromaticity	x	Brightness is on	0.26	0.31	0.36		Note5, Note1
	y		0.28	0.33	0.38		
Luminance	L		280	350	-	cd/m ²	Note1 Note6
Uniformity	U		70	75	-	%	Note1 Note7

Test Conditions:

1. VCC=3.3V, VLED=5.0V , the ambient temperature is 25°C.

Note 1: Definition of optical measurement system.

Temperature = 25°C(±3°C)

LED back-light: ON, Environment brightness < 150 lx

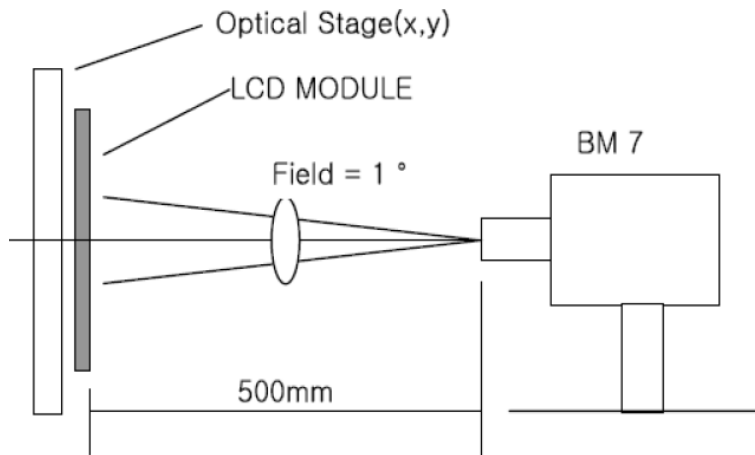

Note 2: Contrast ratio is defined as follow:

$$\text{Contrast Ratio} = \frac{\text{Surface Luminance with all white pixels}}{\text{Surface Luminance with all black pixels}}$$

Note 3: Response time is defined as follow:

Response time is the time required for the display to transition from black to white (Rise Time, Tr) and from white to black(Decay Time, Tf).

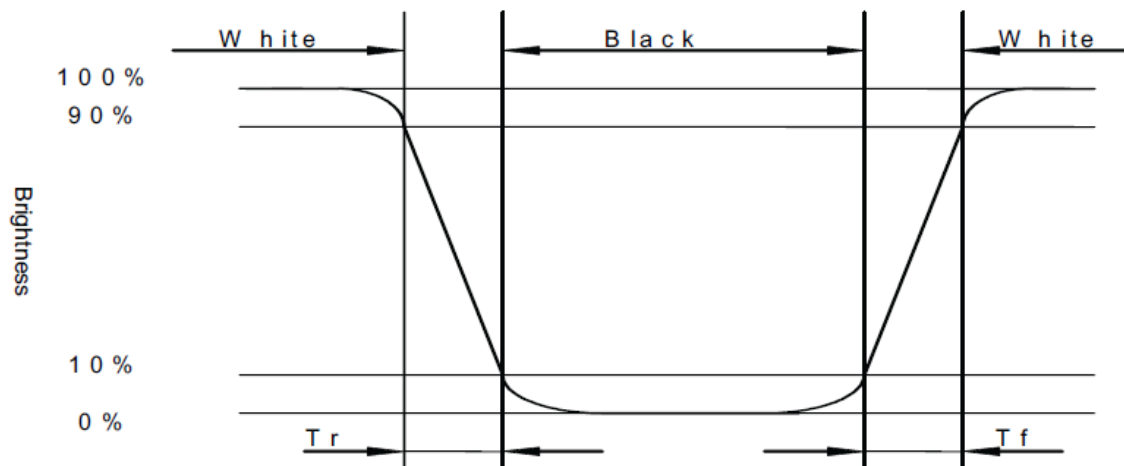

Note 4: Viewing angle range is defined as follow:

Viewing angle is measured at the center point of the LCD.

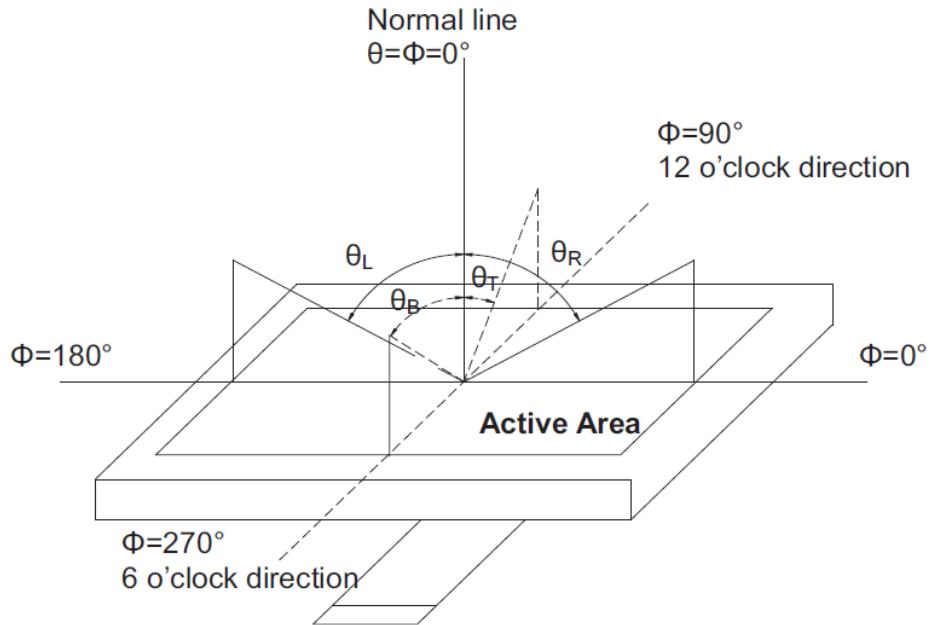

Note 5: Color chromaticity is defined as follow: (CIE1931)

Color coordinates measured at center point of LCD.

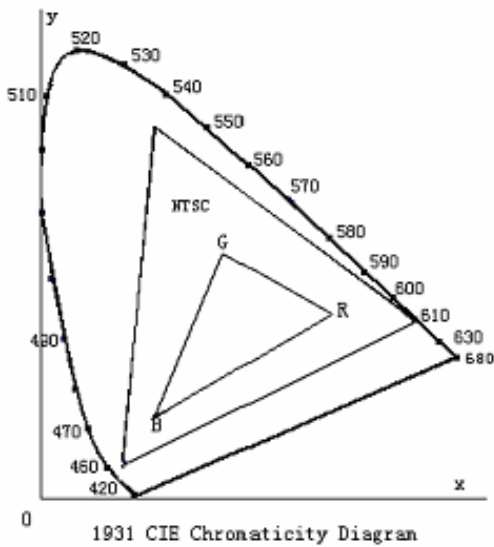

$$S = \frac{\text{area of RGB triangle}}{\text{area of NTSC triangle}} \times 100\%$$

Note 6: Luminance is defined as follow:

Luminance is defined as the brightness of all pixels “White” at the center of display area on optimum contrast.

Note 7: Luminance Uniformity is defined as follow:

Active area is divided into 9 measuring areas (Refer Fig. 2). Every measuring point is placed at the center of each measuring area.

$$\text{Uniformity (U)} = \frac{\text{Minimum Luminance(brightness) in 9 points}}{\text{Maximum Luminance(brightness) in 9 points}}$$

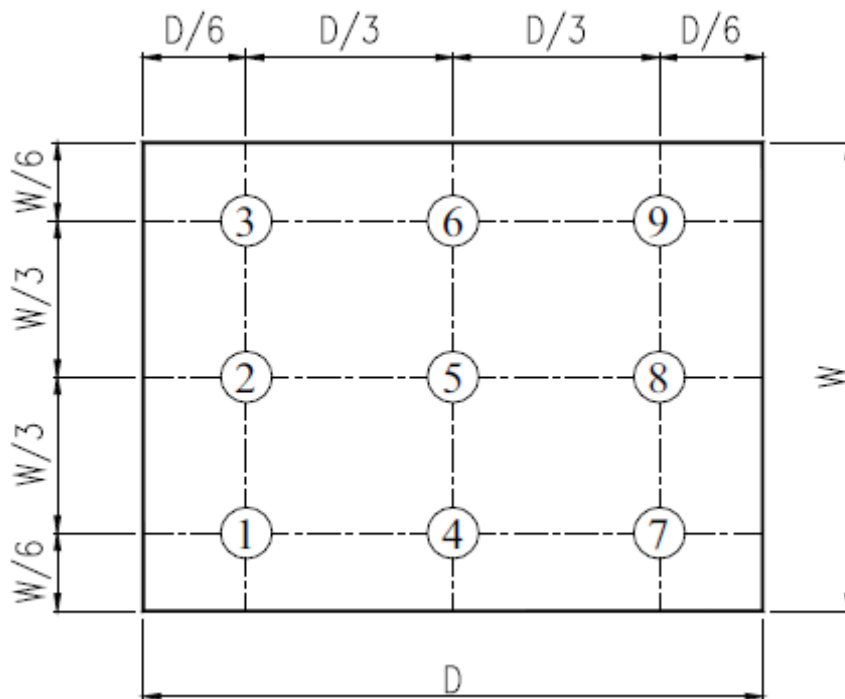

Fig. 2 Definition of uniformity

10. Environmental / Reliability Tests

No	Test Item	Condition	Judgment criteria
1	High Temp Operation	Ts=+70°C, 240hrs	Per table in below
2	Low Temp Operation	Ta=-20°C, 240hrs	Per table in below
3	High Temp Storage	Ta=+80°C, 240hrs	Per table in below
4	Low Temp Storage	Ta=-30°C, 240hrs	Per table in below
5	Operate at High Temperature and Humidity	Ta=+40°C, 90% RH 240 hours	Per table in below (polarizer discoloration is excluded)
6	Thermal Shock (Non-operation)	-30°C/30 min ~ +80°C/30 min for a total 100 cycles, Start with cold temperature and end with high temperature	Per table in below
7	ESD (Operation)	± 2KV, Human Body Mode, 100pF/1500 Ω	Per table in below
8	Vibration (Non-operation)	Random Vibration : 0.015G*G/Hz from 5-200HZ, -6dB/Octave from 200-500HZ 2 hours for each direction of X. Y. Z.(6 hours for total)	Per table in below
9	Shock (Non-operation)	100G 6ms,±X, ±Y, ±Z 3 times for each direction	Per table in below
10	Package Drop Test	Height:60 cm, 1 corner, 3 edges, 6 surfaces	Per table in below

INSPECTION	CRITERION(after test)
Appearance	No Crack on the FPC, on the LCD Panel
Alignment of LCD Panel	No Bubbles in the LCD Panel No other Defects of Alignment in Active area
Electrical current	Within device specifications
Function / Display	No Broken Circuit, No Short Circuit or No Black line No Other Defects of Display

11. Precautions for Use of LCD Modules

11.1 Safety

The liquid crystal in the LCD is poisonous. Do not put it in your mouth. If the liquid crystal touches your skin or clothes, wash it off immediately using soap and water.

11.2 Handling

A. The LCD and touch panel is made of plate glass. Do not subject the panel to mechanical shock or to excessive force on its surface.

B. Do not handle the product by holding the flexible pattern portion in order to assure the reliability

C. Transparency is an important factor for the touch panel. Please wear clear finger sacks, gloves and mask to protect the touch panel from finger print or stain and also hold the portion outside the view area when handling the touch panel.

D. Provide a space so that the panel does not come into contact with other components.

E. To protect the product from external force, put a covering lens (acrylic board or similar board) and keep an appropriate gap between them.

F. Transparent electrodes may be disconnected if the panel is used under environmental conditions where dew condensation occurs.

G. Property of semiconductor devices may be affected when they are exposed to light, possibly resulting in IC malfunctions.

H. To prevent such IC malfunctions, your design and mounting layout shall be done in the way that the IC is not exposed to light in actual use.

11.3 Static Electricity

A. Ground soldering iron tips, tools and testers when they are in operation.

B. Ground your body when handling the products.

C. Power on the LCD module before applying the voltage to the input terminals.

D. Do not apply voltage which exceeds the absolute maximum rating.

E. Store the products in an anti-electrostatic bag or container.

11.4 Storage

A. Store the products in a dark place at $+25^{\circ}\text{C} \pm 10^{\circ}\text{C}$ with low humidity (40% RH to 60% RH). Don't expose to sunlight or fluorescent light.

B. Storage in a clean environment, free from dust, active gas, and solvent.

11.5 Cleaning

A. Do not wipe the touch panel with dry cloth, as it may cause scratch.

B. Wipe off the stain on the product by using soft cloth moistened with ethanol. Do not allow ethanol to get in between the upper film and the bottom glass. It may cause peeling issue or defective operation. Do not use any organic solvent or detergent other than ethanol.

11.6 Cautions for installing and assembling

Bezel edge must be positioned in the area between the Active area and View area. The bezel may press the touch screen and cause activation if the edge touches the active area.

A gap of approximately 0.5mm is needed between the bezel and the top electrode. It may cause unexpected activation if the gap is too narrow. There is a tolerance of 0.2 to 0.3mm for the outside dimensions of the touch panel and tail. A gap must be made to absorb the tolerance in the case and connector.

