



## ASI-T-350EA2AT/D

Item	Contents	Unit
Size	3.5	inch
Resolution	320(RGB) x 240	/
Interface	RGB/CCIR656/601	/
Technology type	a-Si TFT	/
Pixel pitch	0.219x0.219	mm
Pixel Configuration	R.G.B. Vertical Stripe	
Outline Dimension (W x H x D)	76.90 x 64.00 x 4.25	mm
Active Area	70.08 x 52.56	mm
Display Mode	Transmissive Normally White	/
Backlight Type	LED	/



ASI-T-350EA2AT/D

### Record of Revision

Date	Revision No.	Summary
2011-10-12	1.0	Rev 1.0 was issued
2012-07-08	1.1	Modify the total thickness of the module
2013-06-25	1.2	Change the controller



## ASI-T-350EA2AT/D

### 1. Scope

This data sheet is to introduce ASI-T-350EA2AT/D active matrix TFT module. It is composed of a color TFT-LCD panel, driver ICs, FPC, Touch panel and a backlight unit. The 3.5'' display area contains 320(RGB) x 240 pixels.

### 2. Application

Digital equipments which need color display, mobile navigator/video systems.

### 3. General Information

Item	Contents	Unit
Size	3.5	inch
Resolution	320(RGB) x 240	/
Interface	RGB/CCIR656/601	/
Technology type	a-Si TFT	/
Pixel pitch	0.219x0.219	mm
Pixel Configuration	R.G.B. Vertical Stripe	
Outline Dimension (W x H x D)	76.90 x 64.00 x 4.25	mm
Active Area	70.08 x 52.56	mm
Display Mode	Transmissive Normally White	/
Backlight Type	LED	/

4. Outline Drawing

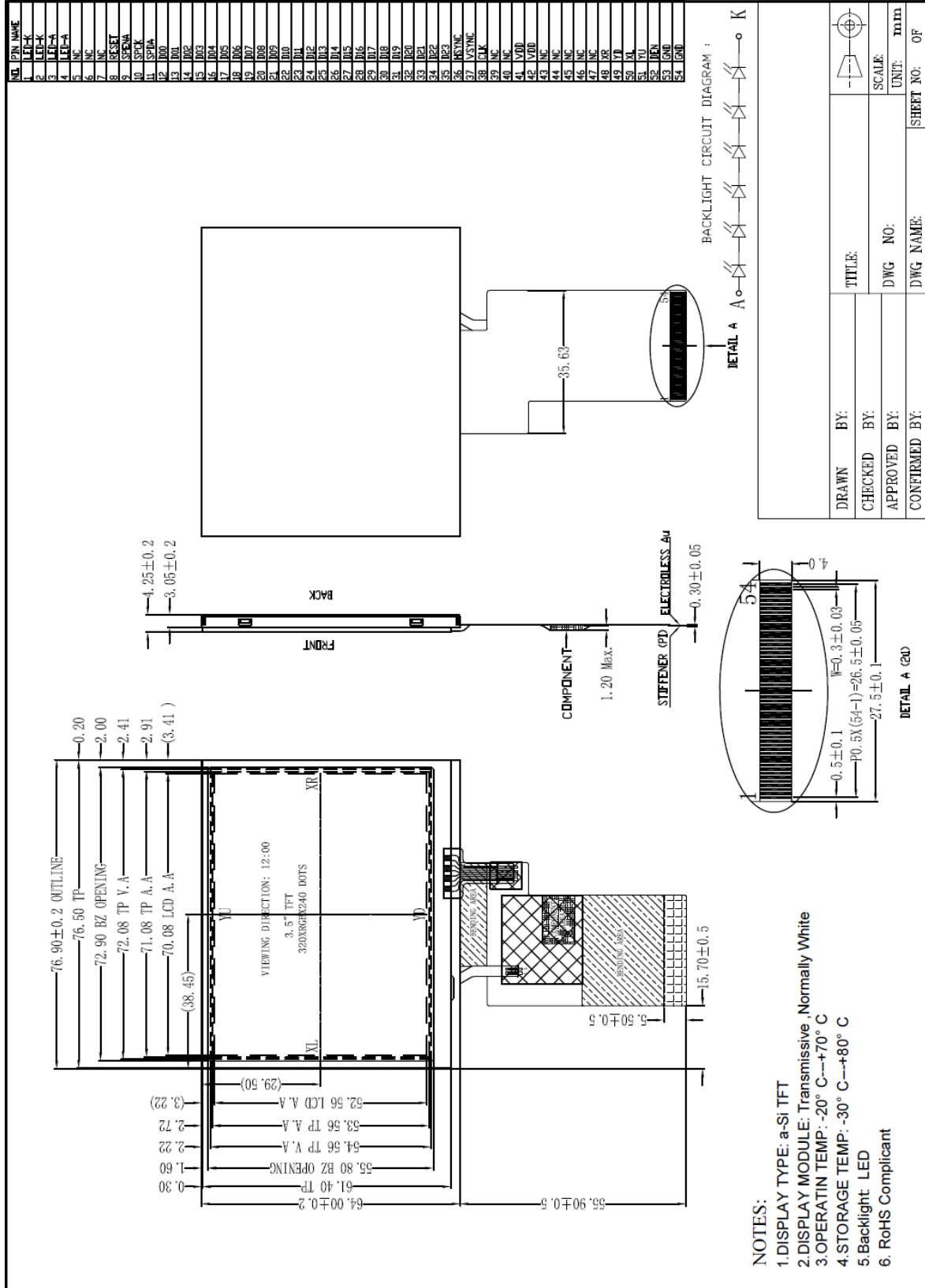



## ASI-T-350EA2AT/D

### 5. Interface signals

No	Symbol	I/O	Description	Remark
1,2	LED_Cathode	I	LED_Cathode	
3,4	LED_Anode	I	LED_Anode	
5	NC	-	No Connect	
6	NC	-	No Connect	
7	NC	-	No Connect	
8	RESET	I	Reset	
9	SPENA	I	Serial port data enable signal	
10	SPCK	I	SPI Serial Clock	
11	SPDA	I/O	SPI Serial Data Input/output	
12	D00	I	Data B0	
13	D01	I	Data B1	
14	D02	I	Data B2	
15	D03	I	Data B3	
16	D04	I	Data B4	
17	D05	I	Data B5	
18	D06	I	Data B6	
19	D07	I	Data B7	
20	D08	I	Data G0	
21	D09	I	Data G1	
22	D10	I	Data G2	
23	D11	I	Data G3	
24	D12	I	Data G4	
25	D13	I	Data G5	
26	D14	I	Data G6	
27	D15	I	Data G7	
28	D16	I	Data R0	
29	D17	I	Data R1	
30	D18	I	Data R2	
31	D19	I	Data R3	
32	D20	I	Data R4	
33	D21	I	Data R5	
34	D22	I	Data R6	
35	D23	I	Data R7	
36	HSYNC	I	Horizontal Synchronous Signal	



## ASI-T-350EA2AT/D

37	VSYNC	I	Vertical Synchronous Signal	
38	CLK	I	Data Clock	
39	NC	-	No Connect	
40	NC	-	No Connect	
41	VDD	P	power supply (3.3V)	
42	VDD	P	power supply (3.3V)	
43	NC	-	No Connect	
44	NC	-	No Connect	
45	NC	-	No Connect	
46	NC	-	No Connect	
47	NC	-	No Connect	
48	XR	-	TOUCH PANEL CONTROL PIN	
49	YD	-	TOUCH PANEL CONTROL PIN	
50	XL		TOUCH PANEL CONTROL PIN	-
51	YU	-	TOUCH PANEL CONTROL PIN	
52	DEN	I	Data enabling signal	
53	GND	P	Ground	
54	GND	P	Ground	

### Note 1:

Mode	D(23:16)	D(15:8)	D(7:0)	HSYNC	VSYNC	DEN
CCIR 656	D(23:16)	GND	GND	NC	NC	NC
CCIR 601	D(23:16)	GND	GND	HSYNC	VSYNC	NC
8 Bit RGB	D(23:16)	GND	GND	HSYNC	VSYNC	NC for HV mode
						DEN for DEN mode
24 Bit RGB	R(7:0)	G(7:0)	B(7:0)	HSYNC	VSYNC	NC for HV mode
						DEN for DEN mode



## ASI-T-350EA2AT/D

### 6. Absolute maximum Ratings

#### 6.1. Electrical Absolute max. ratings

Parameter	Symbol	MIN	MAX	Unit	Remark
Power Supply Voltage	VDD	-0.3	5.0	V	

#### 6.2. Environment Conditions

Item	Symbol	MIN	MAX	Unit	Remark
Operating Temperature	TOPR	-20	70	°C	
Storage Temperature	TSTG	-30	80	°C	

#### 6.3. LED Backlight Absolute max. ratings

Item	Symbol	MIN	MAX	Unit	Remark
LED Forward Current	I <sub>LED</sub>	--	25	mA	For each LED

## 7. Electrical Specifications

### 7.1 Electrical characteristics

GND=0V, Ta=25°C

Item	Symbol	MIN	TYP	MAX	Unit	Remark
Power Supply Voltage	VDD	3.0	3.3	3.6	V	
Input Signal Voltage	VIL	0	--	0.3VCC	V	
	VIH	0.7VCC	--	VCC	V	
(Panel+LSI) Power Consumption	Black Mode(60HZ)		35		mW	
	Sleeping Mode		TBD		mW	

### 7.2 LED Backlight

Ta=25°C

Item	Symbol	MIN	TYP	MAX	Unit	Remark
Forward Current	IF		20		mA	For One LED
Forward Voltage	VF	18	19.2	20.4	V	
Power Consumption	--		384		mW	6 LEDs serial

### 7.3 Schematic of LCD module system

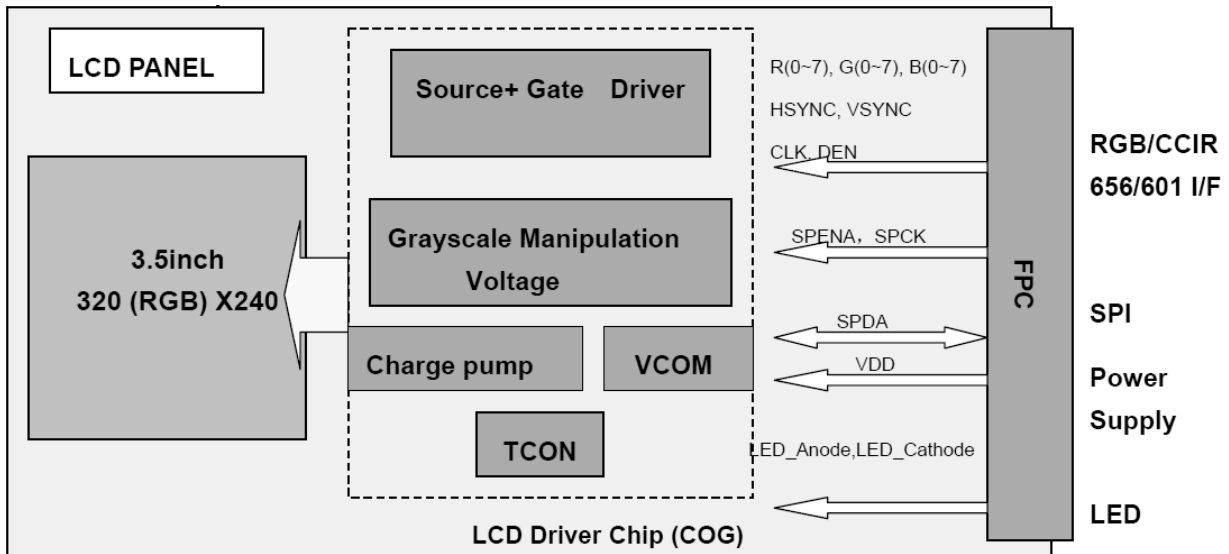



## 8 Command/AC Timing

### 8.1 AC Electrical Characteristics(VDD=3.3V,GND=0V,Ta=25°C

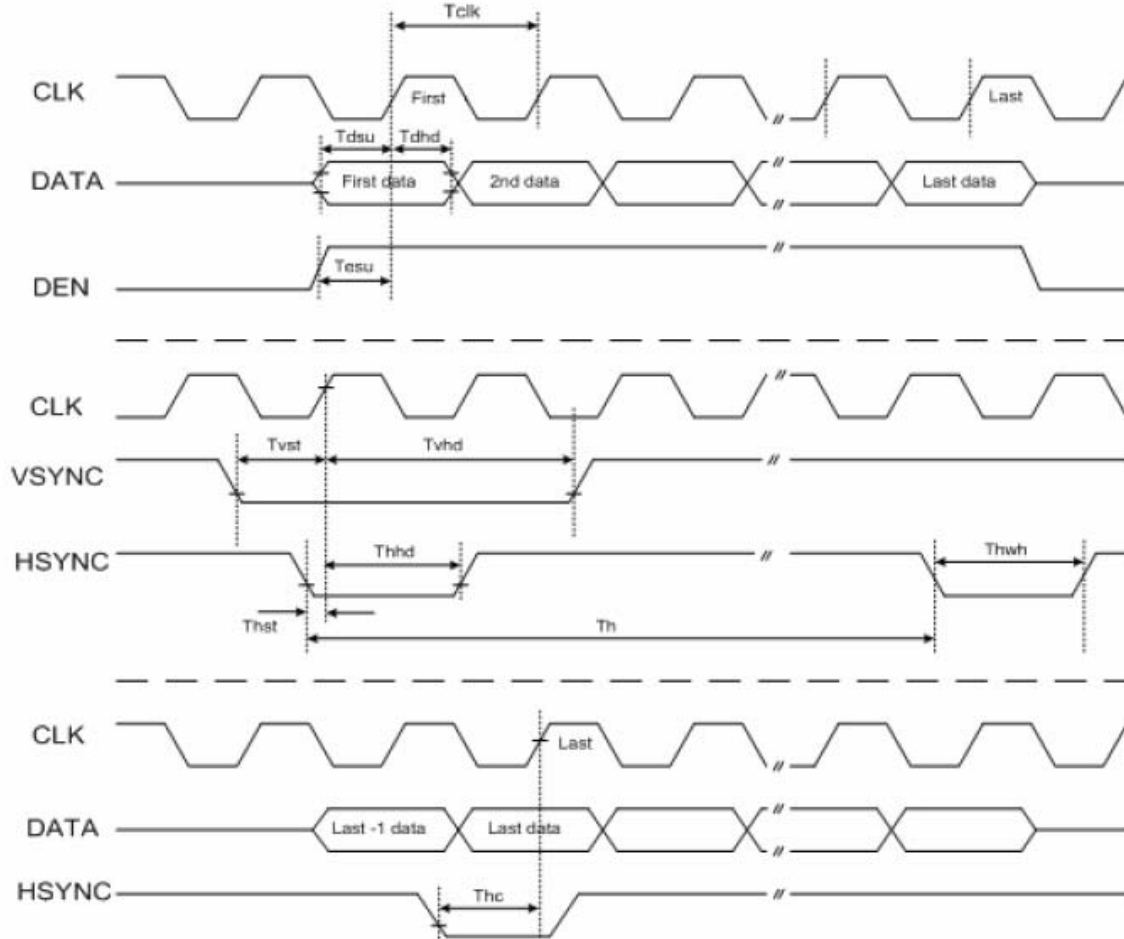

Parameter	Symbol	Min.	Typ.	Max.	Unit	Conditions
CLK clock time	Tclk	-	-	35.7	ns	CLK=28MHz
CLK pulse duty	Tchw	40	50	60	%	Tclk
HSYNC to CLK	Thc	-	-	1	CLK	
HSYNC width	Thwh	1	-	-	CLK	
VSYNC width	Tvwh	1	-	-	Th	
HSYNC period time	Th	60	63.56	67	us	
VSYNC setup time	Tvst	12	-	-	ns	
VSYNC hold time	Tvhd	12	-	-	ns	
HSYNC setup time	Thst	12	-	-	ns	
HSYNC hold time	Thhd	12	-	-	ns	
Data set-up time	Tdsu	12	-	-	ns	D[23:00] to CLK
Data hold time	Tdhd	12	-	-	ns	D[23:00] to CLK
DEN setup time	Tesu	12	-	-	ns	DEN to CLK

8.2 24 bit RGB mode for 320RGB x 240

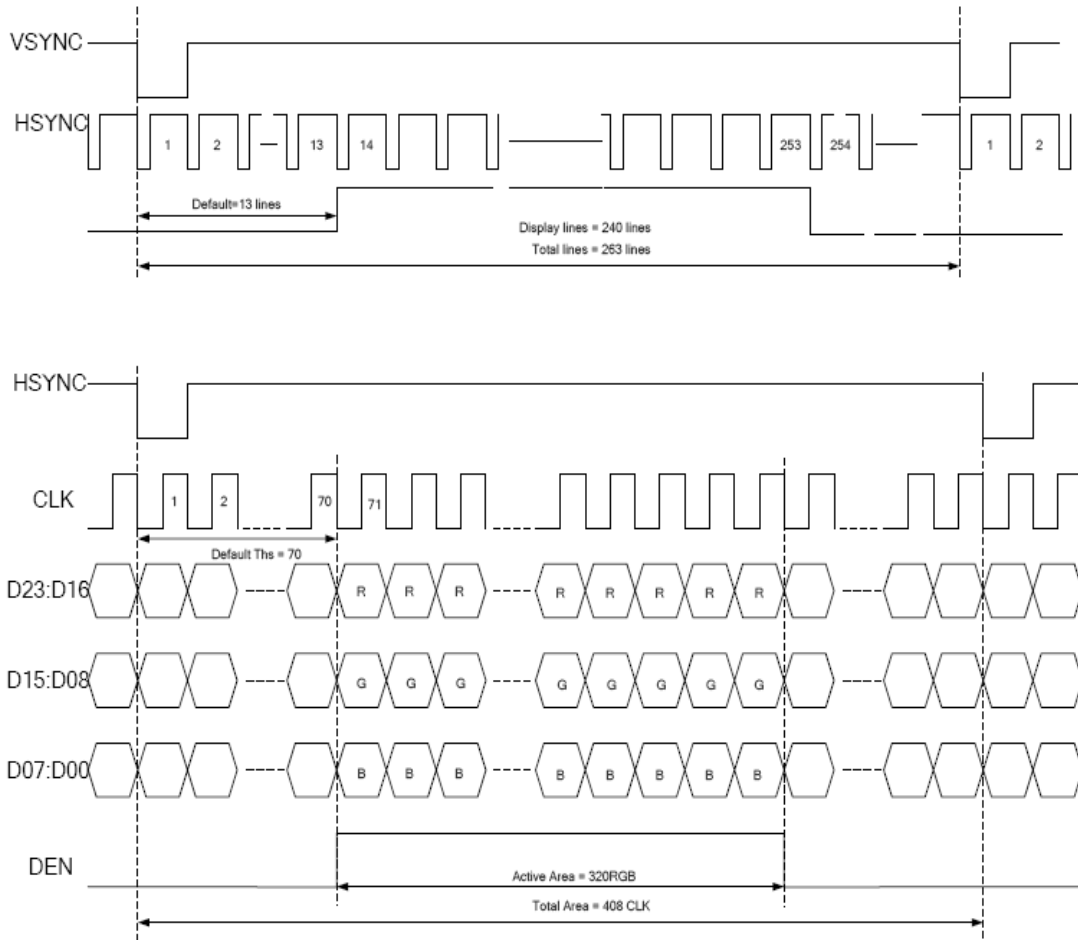

Parameter	Symbol	Min.	Typ.	Max.	Unit	Conditions
CLK frequency	Fclk	-	6.4	-	MHz	VDD=3.0~3.6V
CLK cycle time	Tclk	-	156	-	ns	
Time that HSYNC to 1'st data input(NTSC)	Ths	40	70	255	CLK	

8.38 bit RGB mode for 320RGB x 240

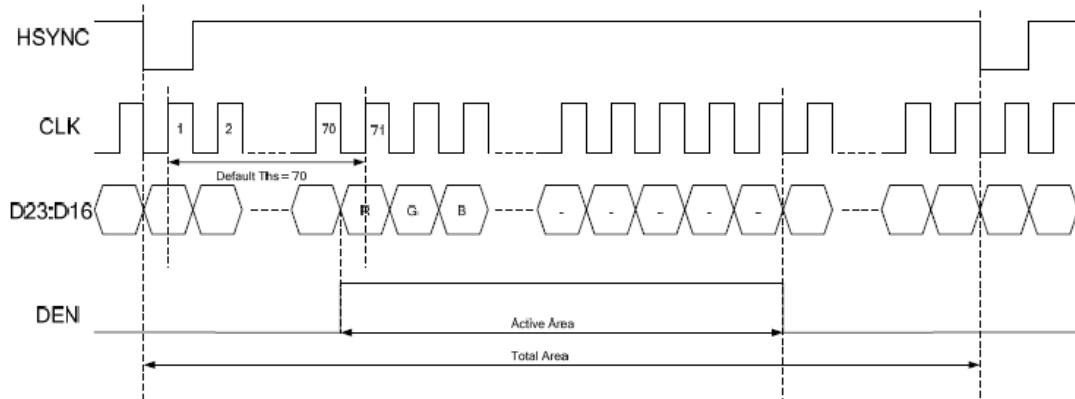

Parameter	Symbol	Min.	Typ.	Max.	Unit	Conditions
CLK frequency	Fclk	-	27	-	MHz	VDD=3.0~3.6V
CLK cycle time	Tclk	-	37	-	ns	
Time that HSYNC to 1'st data input(NTSC)	Ths	35	70	255	CLK	

8.4 ITU-R BT 601

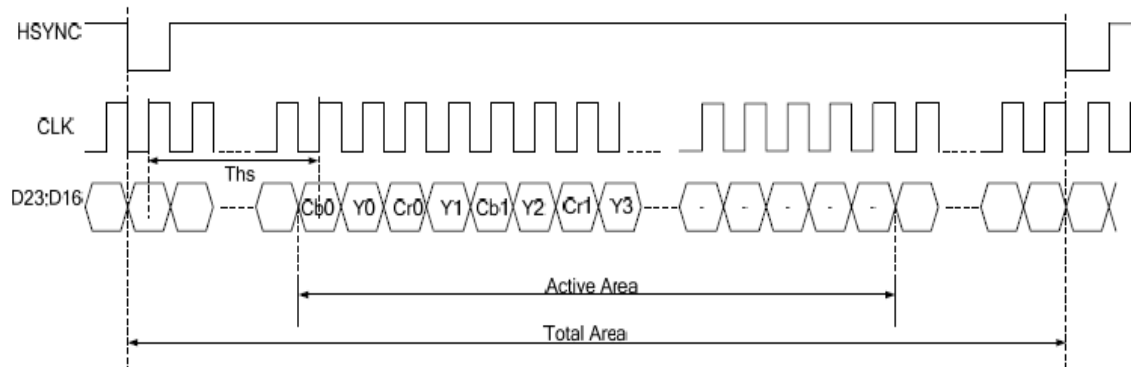

Parameter	Symbol	Min.	Typ.	Max.	Unit	Conditions
CLK frequency	Fclk	-	24.54/27	-	MHz	VDD=3.0~3.6V
CLK cycle time	Tclk	-	40/37	-	ns	
Time from HSYNC to 1'st data input(PAL)	Ths	128	264	-	CLK	
Time from HSYNC to 1'st data input(NTSC)	Ths	128	244	-	CLK	

8.5 ITU-R BT 656

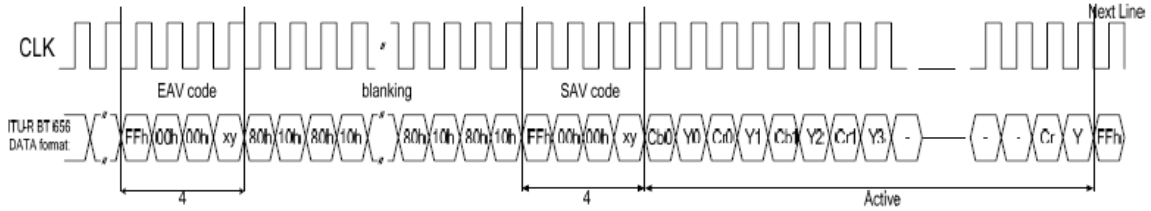

Parameter	Symbol	Min.	Typ.	Max.	Unit	Conditions
CLK frequency	Fclk	-	27	-	MHz	VDD=3.0~3.6V
CLK cycle time	Tclk	-	37	-	ns	
Time from EAV to 1'st data input(PAL)	Ths	128	288	-	CLK	
Time from EAV to 1'st data input (NTSC)	Ths	128	276	-	CLK	

8.6 3-Wire Serial Communication AC Timing

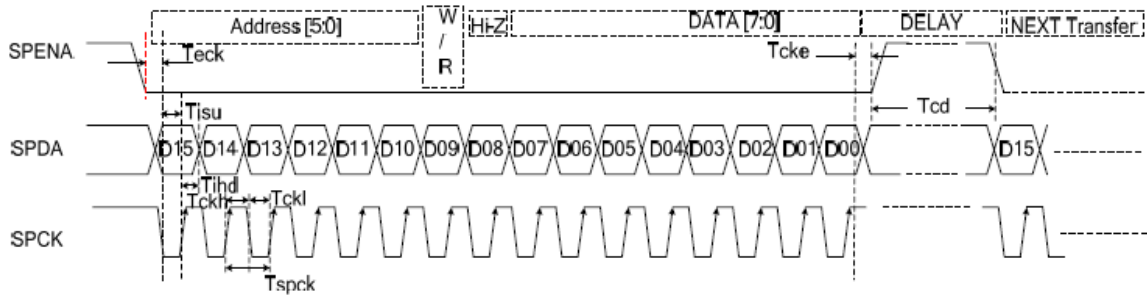

Parameter	Symbol	Min.	Typ.	Max.	Unit	Conditions
SPCK cycle time	Tspck	320	-	-	ns	
SPCK pulse duty	Tscdut	40	50	60	%	
Serial data setup time	Tisu	120	-	-	ns	
Serial data hold time	Tihd	120	-	-	ns	
Serial clock high/low	Tssw	120	-	-	ns	
Chip select distinguish	Tcd	1	-	-	us	



8.7 3-Wire Control Registers List

3-Wire Register		Register Description		
D[15:10]	Name	Init	R/W	Function Description
000000b	R00	07h	R/W	System control register
000001b	R01	00h	R/W	Timing Controller function register
000010b	R02	03h	R/W	Operation control register
000011b	R03	CCh	R/W	Input data Format control register
000100b	R04	46h	R/W	Source Timing delay control register
000101b	R05	0Dh	R/W	Gate Timing delay control register
000110b	R06	00h	R/W	Reserved
000111b	R07	00h	R/W	Internal function control register
001000b	R08	08h	R/W	RGB Contrast control register
001001b	R09	40h	R/W	RGB Brightness control register
001010b	R0A	88h	R/W	Hue / Saturation control register
001011b	R0B	88h	R/W	R / B Sub-Contrast control register
001100b	R0C	20h	R/W	R Sub-Brightness control register
001101b	R0D	20h	R/W	B Sub-Brightness control register
001110b	R0E	10h	R/W	VCOMDC Level control register
001111b	R0F	A4h	R/W	VCOMAC Level control register
010000b	R10	04h	R/W	VGAM2 Level control register
010001b	R11	24h	R/W	VGAM3/4 Level control register
010010b	R12	24h	R/W	VGAM5/6 Level control register
011110b	R1E	00h	R/W	Reserved
100000b	R20	00h	R/W	Wide and narrow display mode control register

Note 5-1:

- R03: c4h:ITU-R BT 656 Mode
- c2h:ITU-R BT 601 Mode
- c8h:8 bit RGB Mode(HV Mode)
- c9h:8 bit RGB Mode(DE Mode)
- cch(default):24 bit RGB Mode (HV mode)
- cdh:24 bit RGB Mode (DE mode)



# ASI-T-350EA2AT/D

## 8.8 Power on/off sequence

Power on sequence

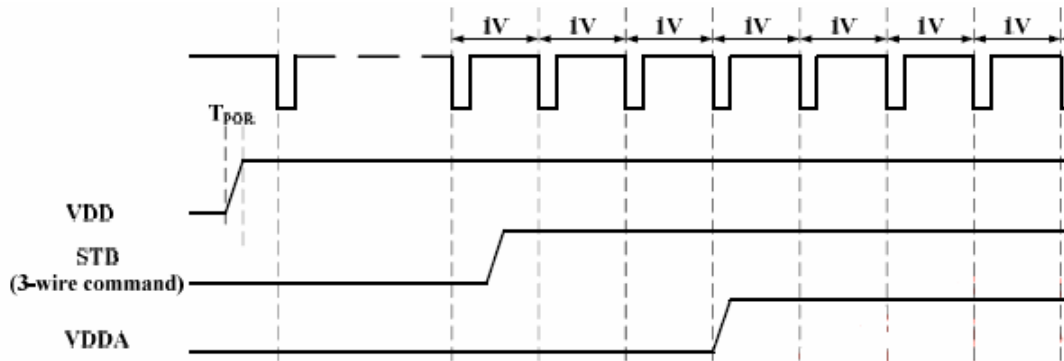

Power off sequence

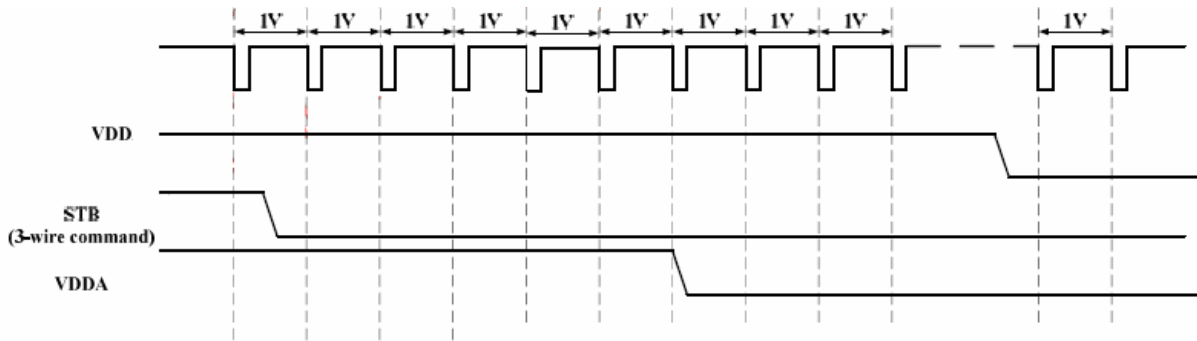



# ASI-T-350EA2AT/D

## 9 Optical Specification

Ta=25°C

Item	Symbol	Condition	Min	Typ.	Max.	Unit	Remark
Contrast Ratio	CR	$\theta=0^\circ$		350	-		Note1 Note2
Response Time	Ton/ Toff	25°C	-	25	40	ms	Note1 Note3
View Angles	$\theta T$	$CR \geq 10$	30	40	-	Degree	Note 4
	$\theta B$		50	60	-		
	$\theta L$		50	60	-		
	$\theta R$		50	60	-		
Chromaticity	White	Brightness is on	x	0.260	0.310	0.360	Note5, Note1
			y	0.283	0.333	0.383	
	Red		x	0.574	0.624	0.674	
			y	0.318	0.368	0.418	
	Green		x	0.300	0.350	0.400	
			y	0.500	0.550	0.600	
	Blue		x	0.093	0.143	0.193	
			y	0.069	0.119	0.169	
NTSC	S		50		%	Note5	
Luminance	L		150	200	-	cd/m <sup>2</sup>	Note1 Note6
Uniformity	U		75	80	-	%	Note1 Note7

Test condition: Vdd=3.3V, If=20mA (Backlight/one LED current), the ambient temperature is 25°C.

Note 1: Definition of optical measurement system.

Temperature = 25°C (±3°C)

LED back-light: ON, Environment brightness < 150 lx

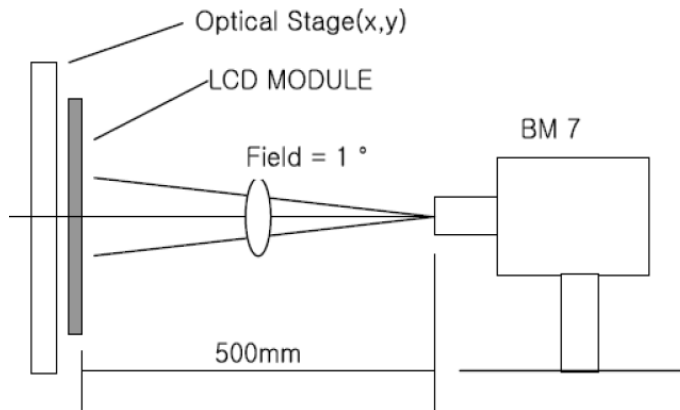

Note 2: Contrast ratio is defined as follow:

$$\text{Contrast Ratio} = \frac{\text{Surface Luminance with all white pixels}}{\text{Surface Luminance with all black pixels}}$$

Note 3: Response time is defined as follow:

Response time is the time required for the display to transition from black to white (Rise Time,  $T_r$ ) and from white to black (Decay Time,  $T_f$ ).

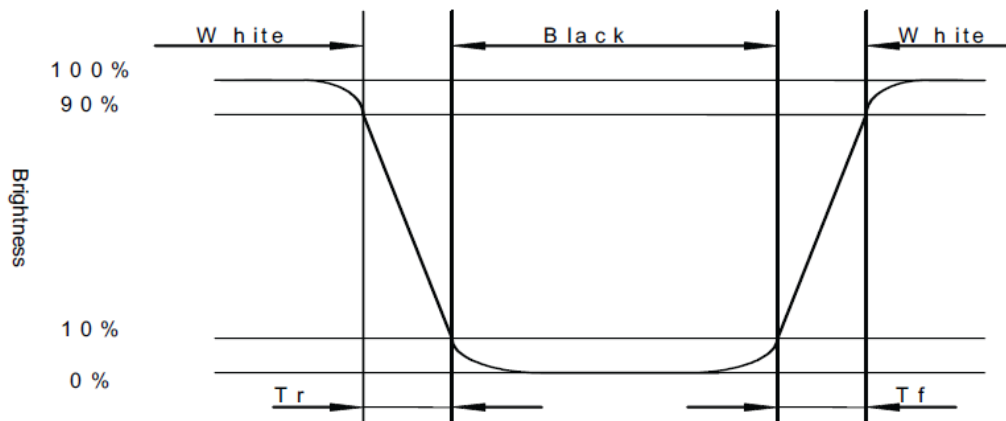



Note 4: Viewing angle range is defined as follow:

Viewing angle is measured at the center point of the LCD.

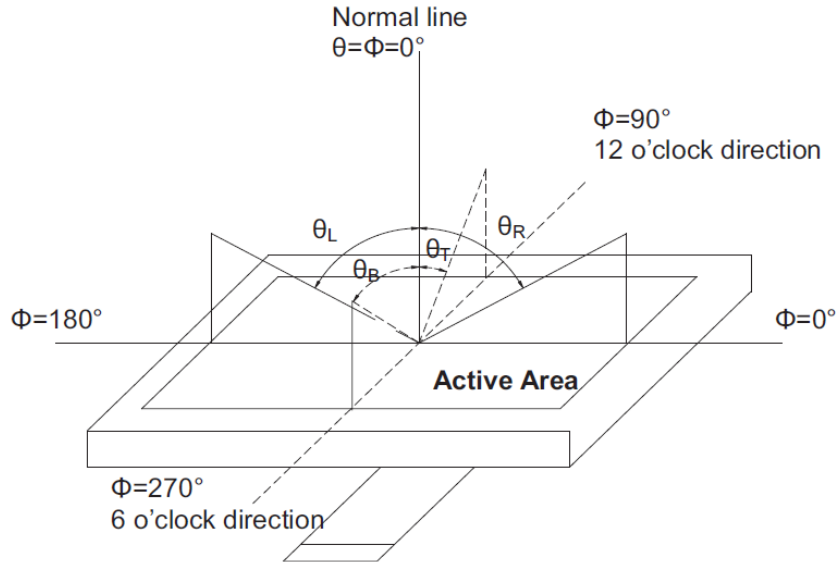

Note 5: Color chromaticity is defined as follow: (CIE1931)

Color coordinates measured at center point of LCD.

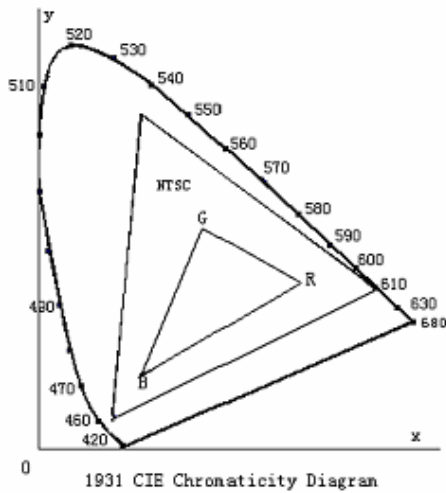

$$S = \frac{\text{area of RGB triangle}}{\text{area of NTSC triangle}} \times 100\%$$

Note 6: Luminance is defined as follow:

Luminance is defined as the brightness of all pixels “White” at the center of display area on optimum contrast.

Note 7: Luminance Uniformity is defined as follow:

Active area is divided into 9 measuring areas (Refer Fig. 2). Every measuring point is placed at the center of each measuring area.

$$\text{Uniformity (U)} = \frac{\text{Minimum Luminance( brightness ) in 9 points}}{\text{Maximum Luminance( brightness ) in 9 points}}$$

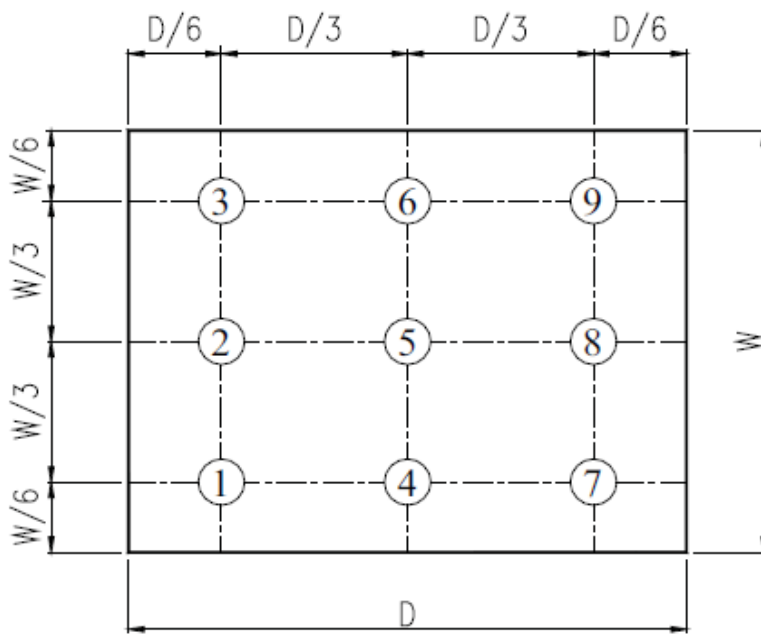

Fig. 2 Definition of uniformity



10 Environmental / Reliability Tests

No	Test Item	Condition	Judgment criteria
1	High Temp Operation	Ts=+70°C, 120hrs	Per table in below
2	Low Temp Operation	Ta=-20°C, 120hrs	Per table in below
3	High Temp Storage	Ta=+80°C, 120hrs	Per table in below
4	Low Temp Storage	Ta=-30°C, 120hrs	Per table in below
5	High Temp & High Humidity Storage	Ta=+60°C, 90% RH 120 hours	Per table in below (polarizer discoloration is excluded)
6	Thermal Shock (Non-operation)	-30°C 30 min~+70°C 30 min, Change time:5min, 10 Cycles	Per table in below
7	ESD (Operation)	C=150pF, R=330Ω , 5points/panel Air:±8KV, 5times; Contact:±4KV, 5 times;	Per table in below
8	Vibration (Non-operation)	Frequency range:10~55Hz, Stroke:1.5mm Sweep:10Hz~55Hz~10Hz 2 hours for each direction of X.Y.Z.	Per table in below
9	Shock (Non-operation)	60G 6ms, ±X,±Y,±Z 3times, for each direction	Per table in below
10	Package Drop Test	Height:80 cm, 1 corner, 3 edges, 6 surfaces	Per table in below

INSPECTION	CRITERION(after test)
Appearance	No Crack on the FPC, on the LCD Panel
Alignment of LCD Panel	No Bubbles in the LCD Panel No other Defects of Alignment in Active area
Electrical current	Within device specifications
Function / Display	No Broken Circuit, No Short Circuit or No Black line No Other Defects of Display

## 11 Precautions for Use of LCD Modules

### 11.1 Safety

The liquid crystal in the LCD is poisonous. Do not put it in your mouth. If the liquid crystal touches your skin or clothes, wash it off immediately using soap and water.

### 11.2 Handling

- A. The LCD and touch panel is made of plate glass. Do not subject the panel to mechanical shock or to excessive force on its surface.
- B. Do not handle the product by holding the flexible pattern portion in order to assure the reliability
- C. Transparency is an important factor for the touch panel. Please wear clear finger sacks, gloves and mask to protect the touch panel from finger print or stain and also hold the portion outside the view area when handling the touch panel.
- D. Provide a space so that the panel does not come into contact with other components.
- E. To protect the product from external force, put a covering lens (acrylic board or similar board) and keep an appropriate gap between them.
- F. Transparent electrodes may be disconnected if the panel is used under environmental conditions where dew condensation occurs.
- G. Property of semiconductor devices may be affected when they are exposed to light, possibly resulting in IC malfunctions.
- H. To prevent such IC malfunctions, your design and mounting layout shall be done in the way that the IC is not exposed to light in actual use.

### 11.3 Static Electricity

- A. Ground soldering iron tips, tools and testers when they are in operation.
- B. Ground your body when handling the products.
- C. Power on the LCD module before applying the voltage to the input terminals.
- D. Do not apply voltage which exceeds the absolute maximum rating.
- E. Store the products in an anti-electrostatic bag or container.

### 11.4 Storage

- A. Store the products in a dark place at  $+25^{\circ}\text{C} \pm 10^{\circ}\text{C}$  with low humidity (40% RH to 60% RH). Don't expose to sunlight or fluorescent light.
- B. Storage in a clean environment, free from dust, active gas, and solvent.

### 11.5 Cleaning

- A. Do not wipe the touch panel with dry cloth, as it may cause scratch.
- B. Wipe off the stain on the product by using soft cloth moistened with ethanol. Do not allow ethanol to get in between the upper film and the bottom glass. It may cause peeling issue or defective operation. Do not use any organic solvent or detergent other than ethanol.

### 11.6 Cautions for installing and assembling

Bezel edge must be positioned in the area between the Active area and View area. The bezel may press the touch screen and cause activation if the edge touches the active area. A gap of approximately 0.5mm is needed between the bezel and the top electrode. It may cause unexpected activation if the gap is too narrow. There is a tolerance of 0.2 to 0.3mm for the outside dimensions of the touch panel and tail. A gap must be made to absorb the tolerance in the case and connector.

