



ASI-T-1040HB4LN/D

Item	Contents	Unit
Size	10.4	inch
Resolution	800(RGB) x 600	/
Interface	LVDS 8-bit / 6-bit	/
Technology type	a-Si TFT	/
Pixel pitch	0.264x0.264	mm
Pixel Configuration	R.G.B. Vertical Stripe	
Outline Dimension (W x H x D)	243.00 x 179.40 x 8.5(max.)	mm
Active Area	211.20 x 158.40	mm
Display Mode	TM with Normally White	/
Surface Treatment (Up polarizer)	Anti-Glare (3H)	/
Backlight Type	LED	/



Record of Revision

Date	Revision No.	Summary
2010-08-10	1.0	Rev 1.0 was issued



ASI-T-1040HB4LN/D

1. Scope

This data sheet is to introduce the specification of ASI-T-1040HB4LN/D active matrix 262k color TFT module. It is composed of a color TFT-LCD panel, driver ICs, FPC and a backlight unit. The 10.4" display area contains 800(RGB) x 600 pixels.

2. Application

Digital equipments which need color display outdoor, mobile navigator/video systems.

3. General Information

Item	Contents	Unit
Size	10.4	inch
Resolution	800(RGB) x 600	/
Interface	LVDS 8-bit / 6-bit	/
Technology type	a-Si TFT	/
Pixel pitch	0.264x0.264	mm
Pixel Configuration	R.G.B. Vertical Stripe	
Outline Dimension (W x H x D)	243.00 x 179.40 x 8.5(max.)	mm
Active Area	211.20 x 158.40	mm
Display Mode	TM with Normally White	/
Surface Treatment (Up polarizer)	Anti-Glare (3H)	/
Backlight Type	LED	/

4. Outline Drawing

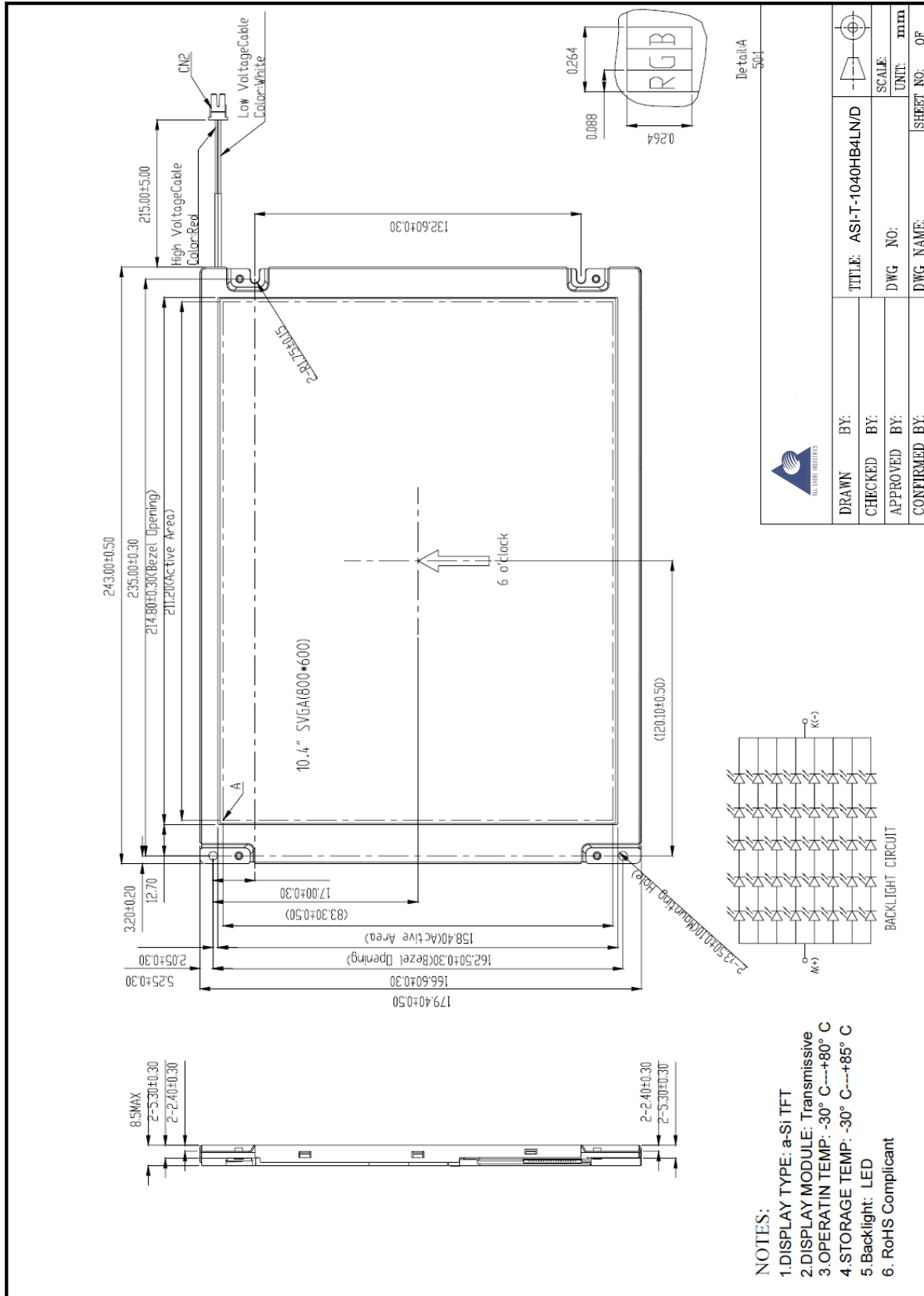

5. Interface signals

5.1 TFT LCD Panel

No	Symbol	I/O	Description	Comment
1	VDD	P	Power Supply	
2	VDD	P	Power Supply	
3	GND	P	Ground	
4	DPS	I	Reverse Scan Function [H: Enable; L/NC: Disable]	Note3
5	RxIN0-	I	LVDS receiver signal channel 0. LVDS Differential Data Input (R0, R1, R2, R3, R4, R5, G0)	Note2
6	RxIN0+	I		
7	GND	P	Ground	
8	RxIN1-	I	LVDS receiver signal channel 1. LVDS Differential Data Input (G1, G2, G3, G4, G5, B0, B1)	Note2
9	RxIN1+	I		
10	GND	P	Ground	
11	RxIN2-	I	LVDS receiver signal channel 2 LVDS Differential Data Input (B2, B3, B4, B5, DE)	Note2
12	RxIN2+	I		
13	GND	P	Ground	
14	RxCLKIN-	I	LVDS receiver signal clock	Note2
15	RxCLKIN+	I		
16	GND	P	Ground	
17	RxIN3-	I	LVDS receiver signal channel 3, NC for 6 bit LVDS Input. LVDS Differential Data Input (R6, R7, G6, G7, B6, B7, RSV) for 8 bit LVDS input.	Note2
18	RxIN3+	I		
19	AG Mode	I	Aging Mode setting [H: Aging Mode; L/NC: Normal]	
20	SEL68	P	6/8bits LVDS data input selection [H: 8bits L/NC: 6bit]	Note2

P: Power/GND; I: input pin;

Note1: CN1 Match Connector type : DF19G-20S-1C or compatible
 Note2: LVDS 6-bit data mapping when SEL68=L/NC as follows:

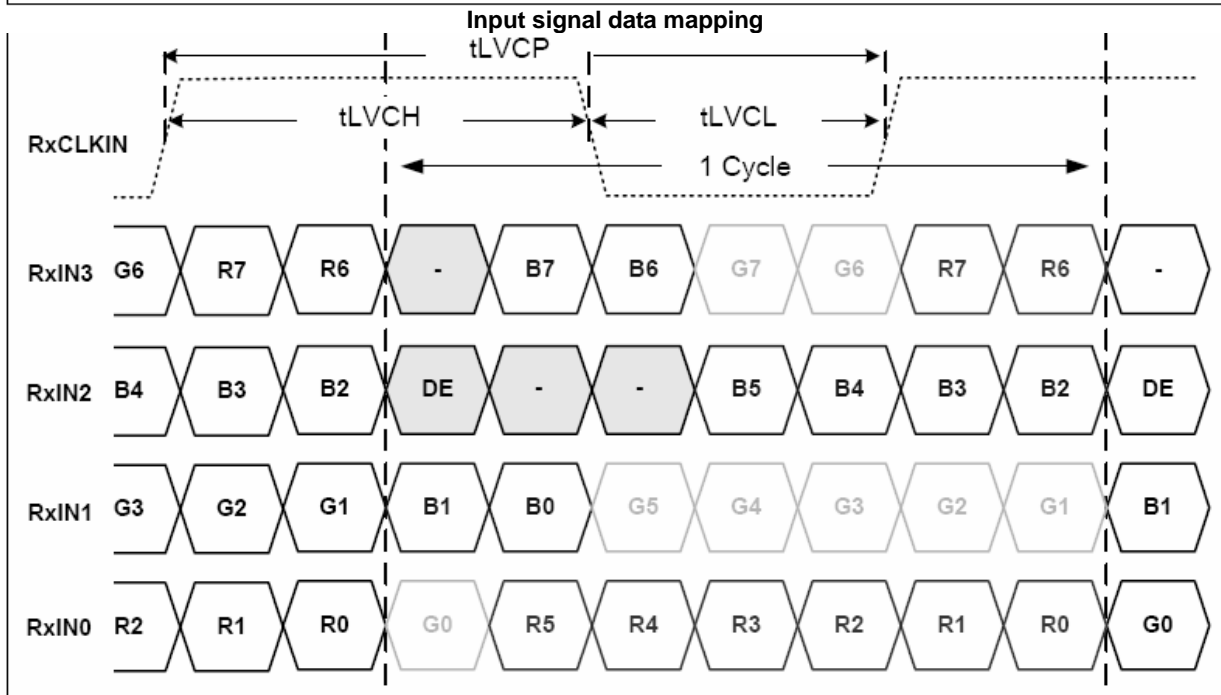
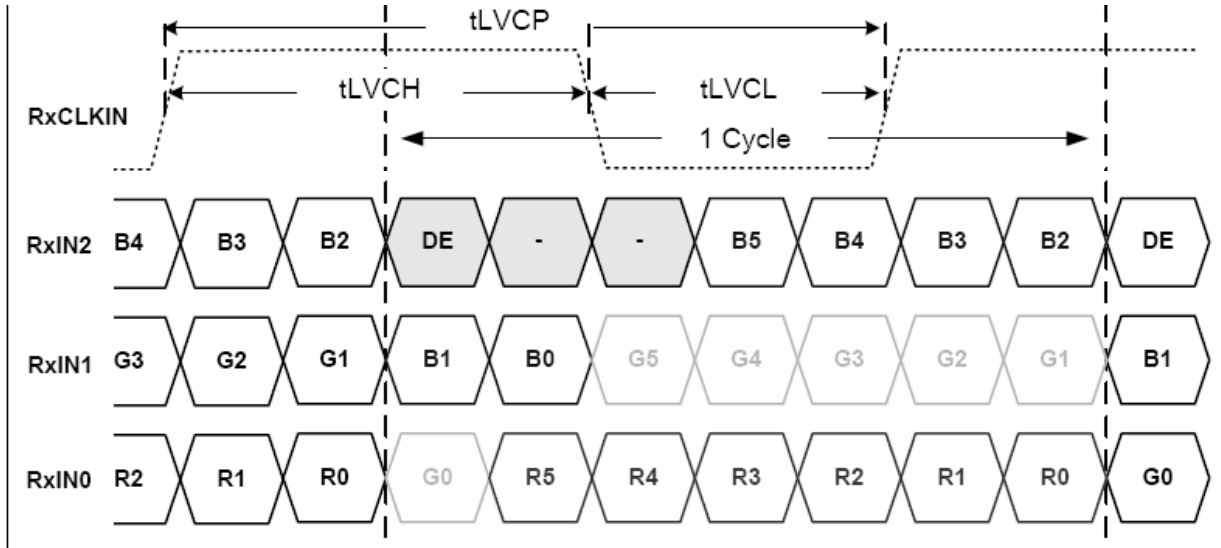

Input signal data mapping

Note3: DPS: Scan direction setting

DPS	Horizontal Scan direction	Vertical Scan direction
High	Right to Left	Down to Up
Low/NC	Left to Right	Up to Down

5.2 CN2 (Backlight Connector) (Match connector: JST SM02B-BHSS-1-TB)

No.	Symbol	I / O	Description	Wire Color
1	LEDA	P	LED driving anode (high voltage)	Red cable
2	LEDK	P	LED driving cathode (low voltage)	White cable



6. Absolute maximum Ratings

6.1. Electrical Absolute max. ratings

Parameter	Symbol	MIN	MAX	Unit	Remark
Power Voltage	VDD	-0.3	5.0	V	
input voltage	VIN	-0.3	5.0	V	

6.2. Environment Conditions

Item	Symbol	MIN	MAX	Unit	Remark
Operating Temperature	TOPR	-30	80	°C	
Storage Temperature	TSTG	-30	85	°C	

7. Electrical Specifications

7.1 Electrical characteristics

GND=0V, Ta=25°C

Item	Symbol	MIN	TYP	MAX	Unit	Remark
LVDS Differential input high threshold	VTH	-	-	+100	mV	VCMLVDS=1.2V
LVDS Differential input low threshold	VTL	-100	-	-	mV	VCMLVDS=1.2V
Differential input voltage	VID	0.1	-	0.6	V	
LVDS input common mode voltage	VCMLVDS	VID /2	-	1.4-(VID /2)	V	
Input current	IIN	-10	-	10	μA	
Supply Voltage	VDD	3.0	3.3	3.6	V	
Common Electrode Driving Signal	VCOM	-	4.30	-	V	Note1
SYNC Frequency	FVD	-	60	70	Hz	
VDD Power Consumption	IDD	-	TBD	380	mA	Note2

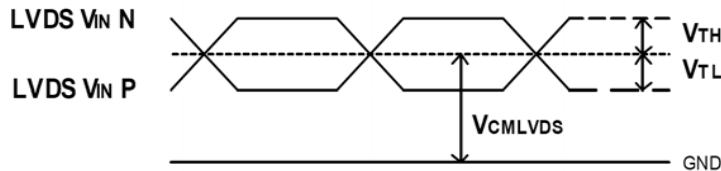

LVDS DC TIMING DIAGRAM

Note1: For different LCM, the value may have a bit of difference.

Note2: To test the current dissipation, use "all Black Pattern" testing pattern.

7.2 LED Backlight driving conditions

Ta=25°C

Item	Symbol	MIN	TYP	MAX	Unit	Remark
Forward Current	IF	--	200	--	mA	Note 1
Forward Voltage	VF	15	--	19	V	Note 2
Power Consumption	WBL	--	3.4	--	W	Note 1
LED Life Time		30000	50000	--	hrs	Note 3

Note 1: The LED driving condition is defined for total backlight consumption.

Note 2: Forward Voltage adjusting should depend on Forward Current setting.

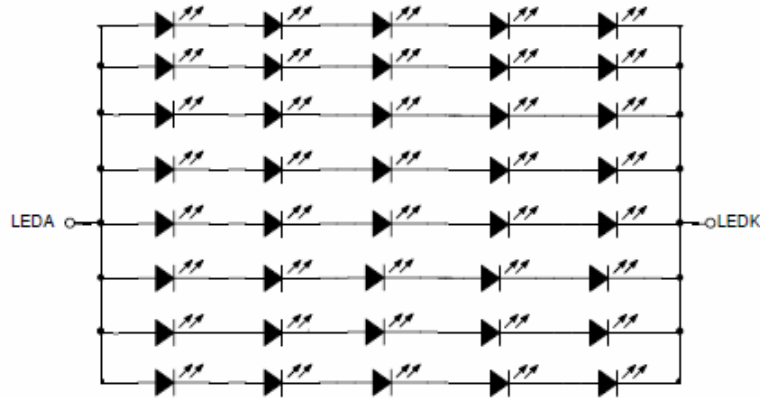

LED connection of Backlight

Note 3: IF is defined for one channel LED.

Optical performance should be evaluated at Ta=25°C only. If LED is driven by high current, high ambient temperature and humidity conditions, the lifetime of LED will be reduced.

Operating life time means brightness goes down to 50% initial brightness. Typical operating life time is estimated data.

7.3 Schematic of LCD module system

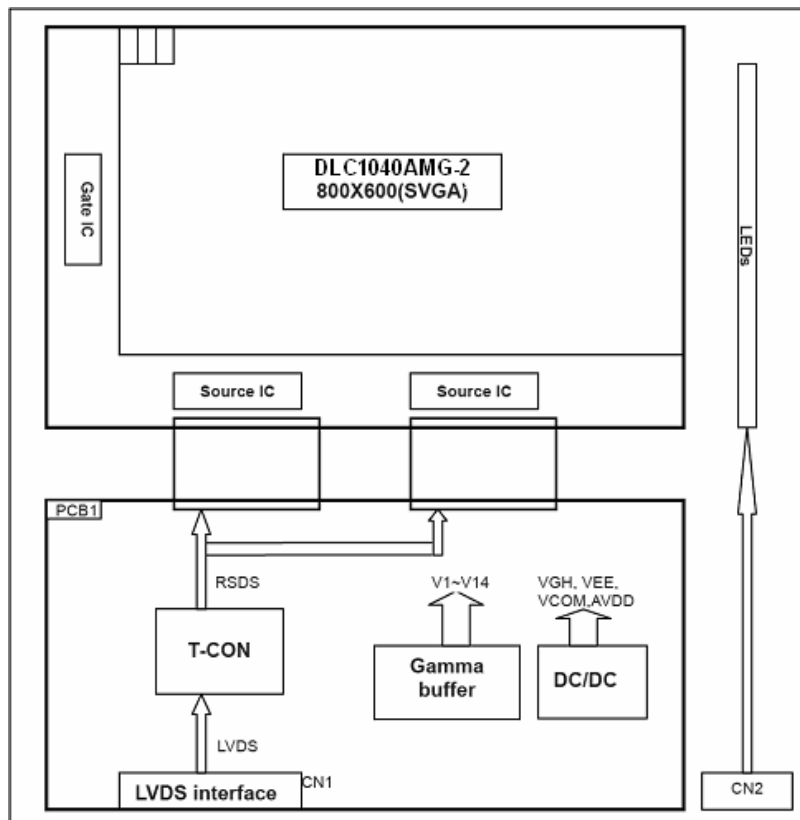

8. Command/AC Timing

8.1 Timing Characteristics

Item	Symbol	MIN	TYP	MAX	Unit	Condition
Clock period	tLVCP	20.0	25.0	31.25	ns	
Clock high time	tLVCH	-	14.29	-	ns	
Clock low time	tLVCL	-	10.71	-	ns	
PLL wake-up time	tLVPLL	-	-	1.0	ms	
Input skew margin	tLVSKM	400	-	-	ps	f=85MHz

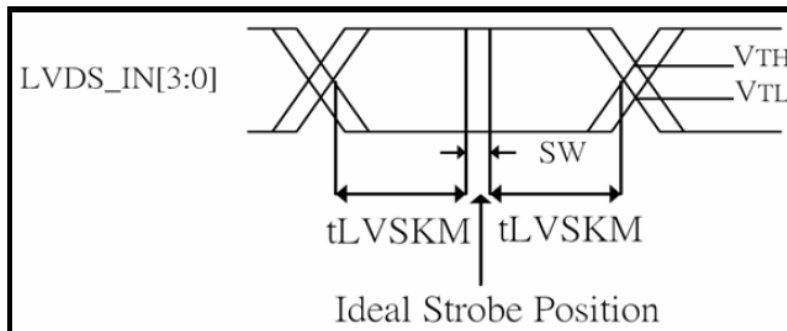
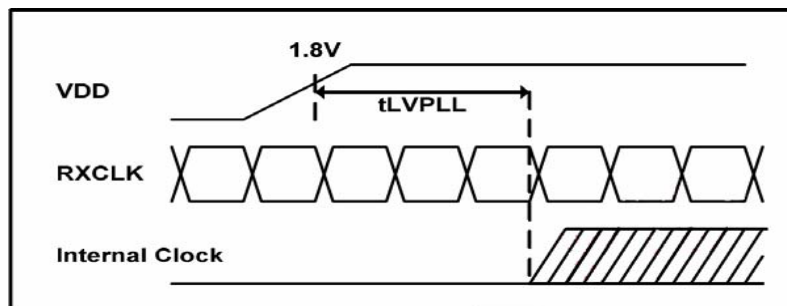

SW: Setup and Hold time

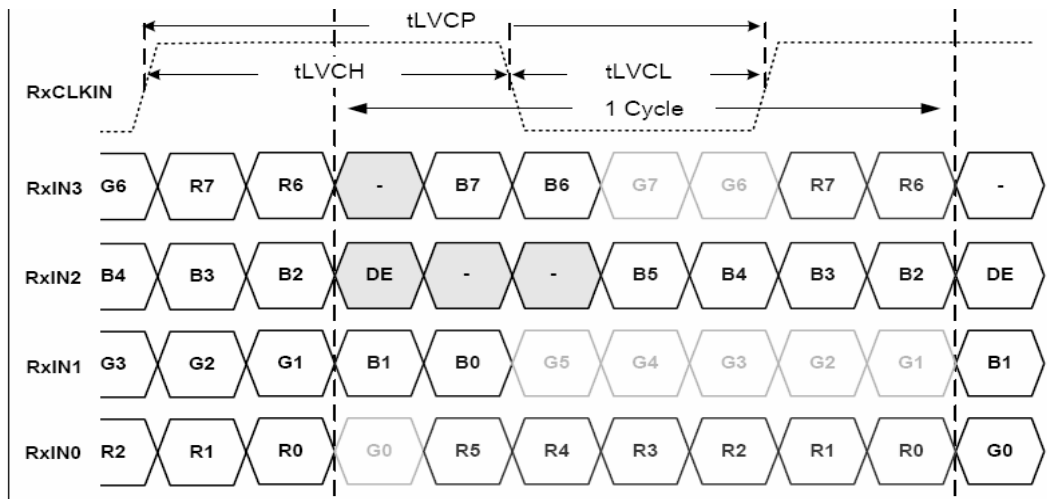

Input signal data timing

8.2 Power ON/Off Sequence

Item	Symbol	MIN	TYP	MAX	Unit	Remark
VDD 3.0V to signal starting	Tp1	5	-	50	ms	
Signal starting to backlight on	Tp2	150	-	-	ms	
Signal off to VDD 3.0V	Tp3	5	-	50	ms	
Backlight off to signal off	Tp4	150	-	-	ms	

Interface power on/off sequence

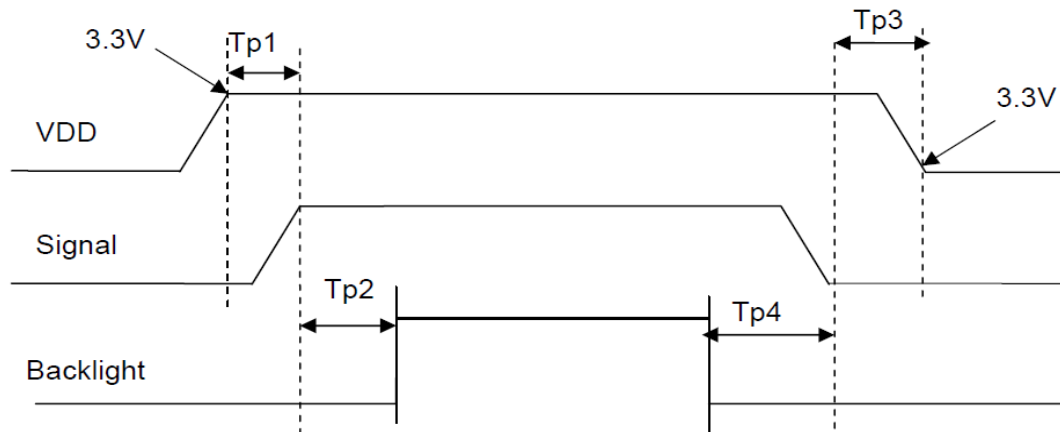

8.3 APPLICATION NOTES

8.3.1 Recommended Input Timing of LVDS transmitter

Parameter	Symbol	MIN	TYP	MAX	Unit	Remark
Dclk frequency	1/Tclk	32	40	50	MHz	
Horizontal section	Horizontal total	Th	866	1056	1064	Tclk
	Horizontal blanking	Thb	66	256	264	Tclk
	Valid Data Width	Thd	800	800	800	Tclk
Vertical section	Frame rate	-	-	60	70	Hz
	Vertical total	Tv	604	628	800	Th
	Vertical blanking	Tvb	4	28	200	Th
	Valid Data Width	Tvd	600	600	600	Th

Note: DE signal is necessary.

Input Timing Control Conditions

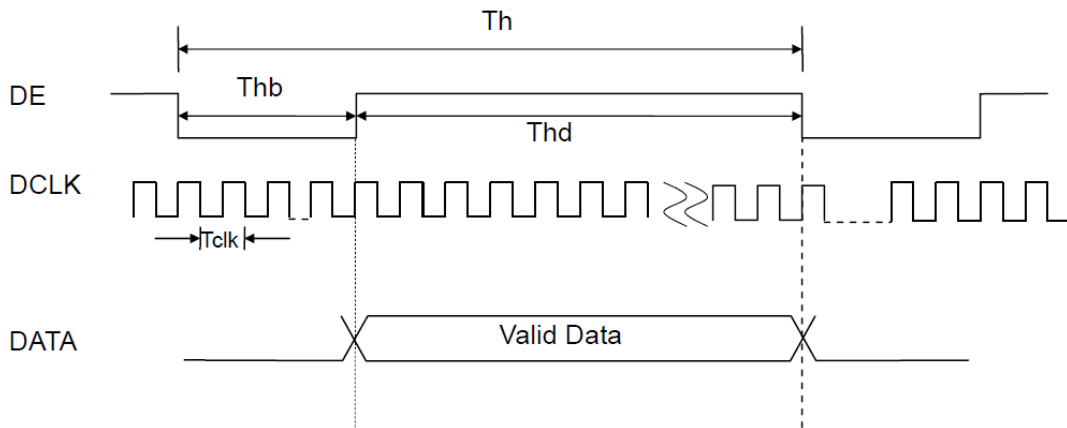
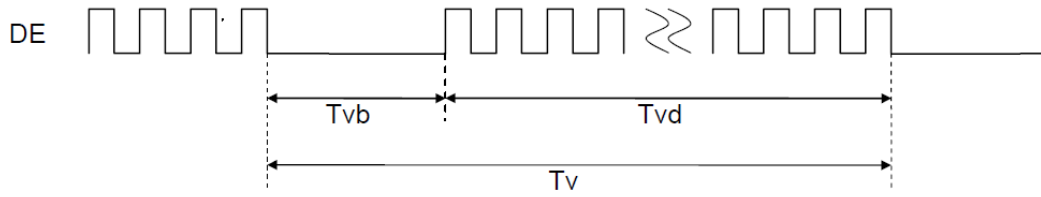

9. Optical Specification

Ta=25°C

Item	Symbol	Condition	Min	Typ.	Max.	Unit	Remark	
Contrast Ratio	CR	$\theta=0^\circ$	400	500	--		Note1 Note3	
Response Time	Ton	25°C	--	10	15	ms	Note1 Note4	
	Toff		--	15	25			
View Angles	θT	$CR \geq 10$	50	60	--	Degree	Note 2	
	θB		60	70	--			
	θL		60	70	--			
	θR		60	70	--			
Chromaticity	White	Brightness is on	x	0.2545	0.3045	0.3545	--	Note5, Note1
			y	0.2946	0.3446	0.3946		
	Red		x	0.5592	0.6092	0.6592		
			y	0.3052	0.3552	0.4052		
	Green		x	0.2649	0.3149	0.3649		
			y	0.5053	0.5553	0.6053		
	Blue		x	0.0897	0.1367	0.1897		
			y	0.0896	0.1396	0.1896		
Uniformity	U		--	80	-	%	Note1 Note6	
NTSC	S		-	50	-	%	Note 5	
Luminance	L		300	400	-	cd/m ²	Note1 Note7	

Note 1: Definition of optical measurement system.

Temperature = 25°C (±3°C)

LED back-light: ON, Environment brightness < 150 lx

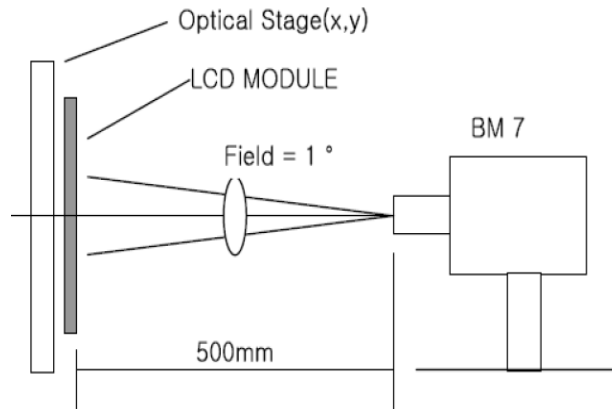

Note 2: Viewing angle range is defined as follow:

Viewing angle is measured at the center point of the LCD.

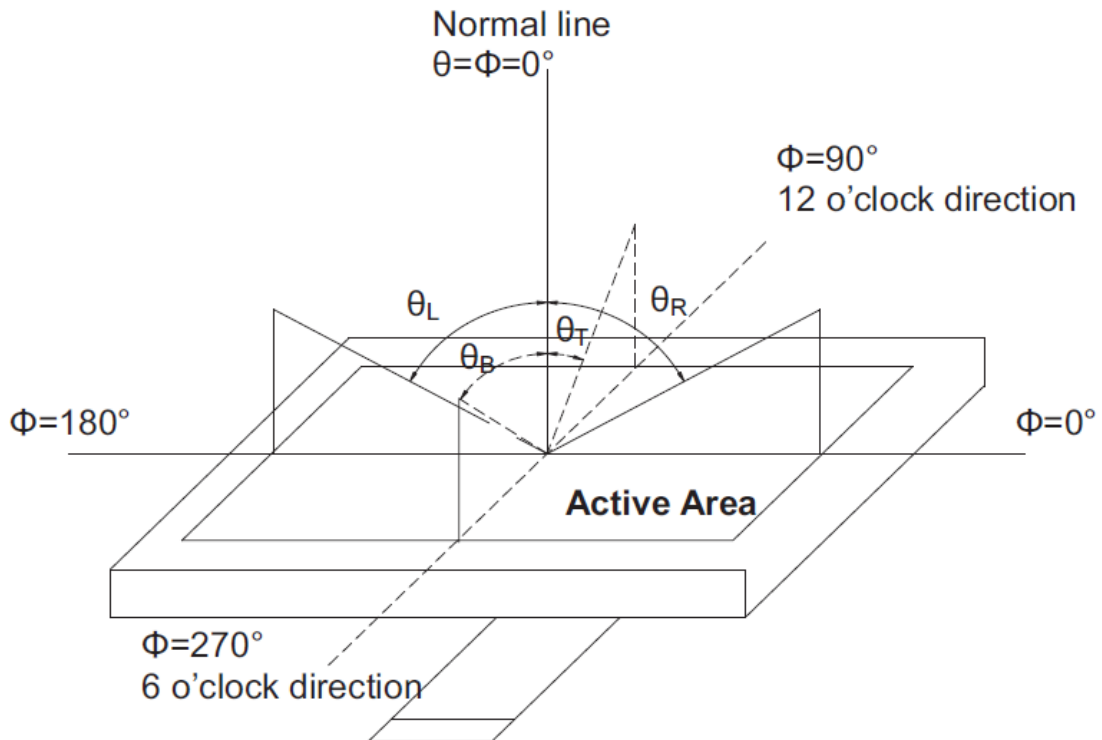

Note 3: Contrast ratio is defined as follow:

$$\text{Contrast Ratio} = \frac{\text{Surface Luminance with all white pixels}}{\text{Surface Luminance with all black pixels}}$$

Note 4: Response time is defined as follow:

Response time is the time required for the display to transition from black to white (Rise Time, Tr) and from white

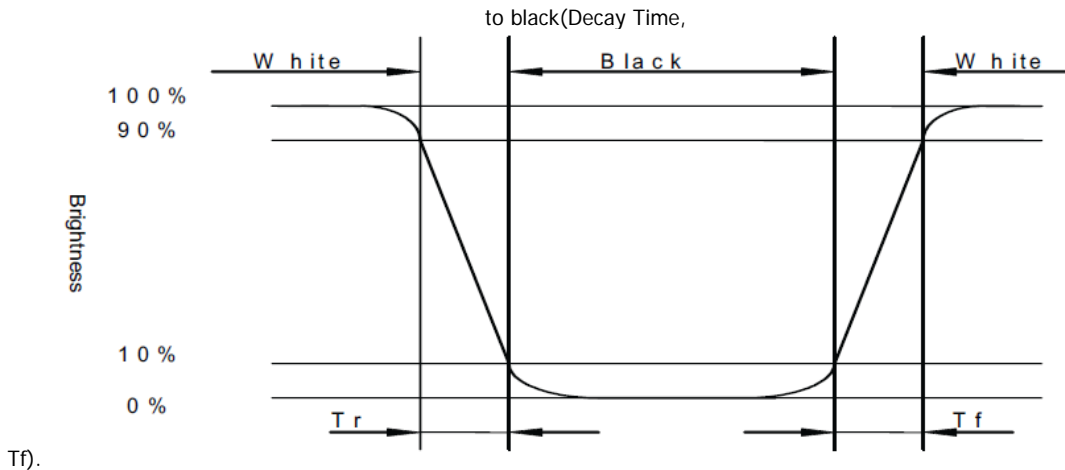

Note 5: Color chromaticity is defined as follow: (CIE1931)

Color coordinates measured at center point of LCD.

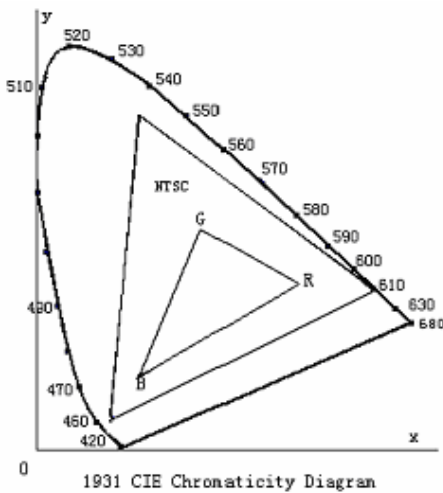

$$S = \frac{\text{area of RGB triangle}}{\text{area of NTSC triangle}} \times 100\%$$

Note 6: Luminance Uniformity is defined as follow:

Active area is divided into 9 measuring areas (Refer Fig. 2). Every measuring point is placed at the center of each measuring area.

$$\text{Uniformity (U)} = \frac{\text{Minimum Luminance(brightness) in 9 points}}{\text{Maximum Luminance(brightness) in 9 points}}$$

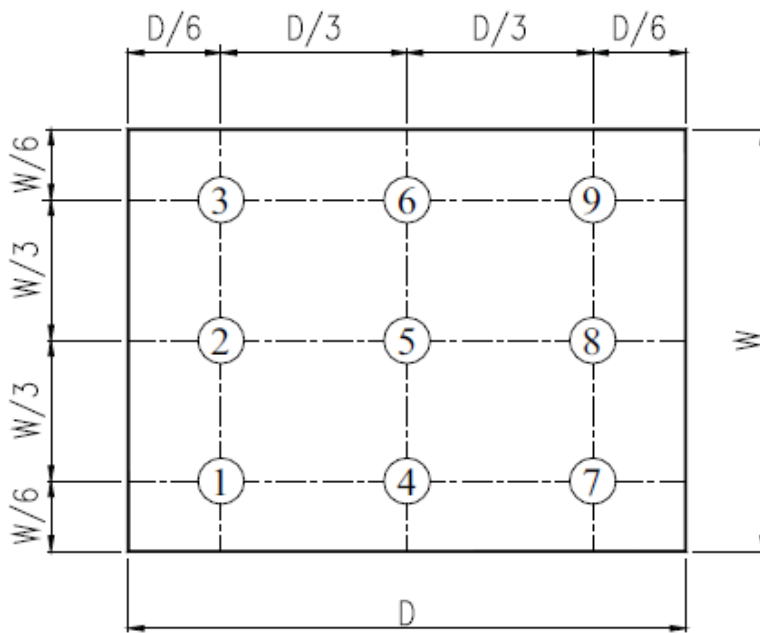

Fig. 2 Definition of uniformity

Note 7: Luminance is defined as follow:

Luminance is defined as the brightness of all pixels “White” at the center of display area on optimum contrast.

10. Environmental / Reliability Tests

No	Test Item	Condition	Judgment criteria
1	High Temp Operation	Ts=+80°C, 240hrs	Per table in below
2	Low Temp Operation	Ta=-30°C, 240hrs	Per table in below
3	High Temp Storage	Ta=+85°C, 240hrs	Per table in below
4	Low Temp Storage	Ta=-30°C, 240hrs	Per table in below
5	High Temp & High Humidity Storage	Ta=+60°C, 90% RH 240 hours	Per table in below (polarizer discoloration is excluded)
6	Thermal Shock (Non-operation)	-30°C 30 min~+85°C 30 min, Change time:5min, 100 Cycles	Per table in below
7	ESD (Operation)	C=150pF, R=330Ω · 5points/panel Air:±8KV, 5times; Contact:±4KV, 5 times;	Per table in below
8	Vibration (Non-operation)	Frequency range:10~55Hz, Stroke:1.5mm Sweep:10Hz~55Hz~10Hz 2 hours for each direction of X.Y.Z.	Per table in below
9	Shock (Non-operation)	80G 6ms, ±X,±Y,±Z 3times for each direction	Per table in below
10	Package Drop Test	Height:80 cm, 1 corner, 3 edges, 6 surfaces	Per table in below

INSPECTION	CRITERION(after test)
Appearance	No Crack on the FPC, on the LCD Panel
Alignment of LCD Panel	No Bubbles in the LCD Panel No other Defects of Alignment in Active area
Electrical current	Within device specifications
Function / Display	No Broken Circuit, No Short Circuit or No Black line No Other Defects of Display

11. Precautions for Use of LCD Modules

11.1 Safety

The liquid crystal in the LCD is poisonous. Do not put it in your mouth. If the liquid crystal touches your skin or clothes, wash it off immediately using soap and water.

11.2 Handling

- A. The LCD and touch panel is made of plate glass. Do not subject the panel to mechanical shock or to excessive force on its surface.
- B. Do not handle the product by holding the flexible pattern portion in order to assure the reliability
- C. Transparency is an important factor for the touch panel. Please wear clear finger sacks, gloves and mask to protect the touch panel from finger print or stain and also hold the portion outside the view area when handling the touch panel.
- D. Provide a space so that the panel does not come into contact with other components.
- E. To protect the product from external force, put a covering lens (acrylic board or similar board) and keep an appropriate gap between them.
- F. Transparent electrodes may be disconnected if the panel is used under environmental conditions where dew condensation occurs.
- G. Property of semiconductor devices may be affected when they are exposed to light, possibly resulting in IC malfunctions.
- H. To prevent such IC malfunctions, your design and mounting layout shall be done in the way that the IC is not exposed to light in actual use.

11.3 Static Electricity

- A. Ground soldering iron tips, tools and testers when they are in operation.
- B. Ground your body when handling the products.
- C. Power on the LCD module before applying the voltage to the input terminals.
- D. Do not apply voltage which exceeds the absolute maximum rating.
- E. Store the products in an anti-electrostatic bag or container.

11.4 Storage

- A. Store the products in a dark place at $+25^{\circ}\text{C} \pm 10^{\circ}\text{C}$ with low humidity (40% RH to 60% RH). Don't expose to sunlight or fluorescent light.
- B. Storage in a clean environment, free from dust, active gas, and solvent.

11.5 Cleaning

- A. Do not wipe the touch panel with dry cloth, as it may cause scratch.
- B. Wipe off the stain on the product by using soft cloth moistened with ethanol. Do not allow ethanol to get in between the upper film and the bottom glass. It may cause peeling issue or defective operation. Do not use any organic solvent or detergent other than ethanol.

11.6 Cautions for installing and assembling

Bezel edge must be positioned in the area between the Active area and View area. The bezel may press the touch screen and cause activation if the edge touches the active area. A gap of approximately 0.5mm is needed between the bezel and the top electrode. It may cause unexpected activation if the gap is too narrow. There is a tolerance of 0.2 to 0.3mm for the outside dimensions of the touch panel and tail. A gap must be made to absorb the tolerance in the case and connector.

