



ASI-O-242FAYYH10/M

OLED MODULE SPECIFICATION

No.	Items	Specification	Unit
1	Display Mode	Passive Matrix OLED	-
2	Display Color	Monochrome (Yellow)	-
3	Duty	1/64	-
4	Resolution	128(H) x 64(V)	Pixel
5	Active Area	55.01 (W) x 27.49 (H)	mm
6	Outline Dimension	60.50 (W) x 37.00 (H) x 2.00 (D)	mm
7	Pixel Pitch	0.43 (W) x 0.43 (H)	mm
8	Pixel Size	0.40 (W) x 0.40 (H)	mm
9	Driver IC	SSD1309	-
10	Interface	8-bit parallel,4-wire SPI,I2C	-
11	Weight	8.81	g



CONTENT

- PHYSICAL DATA
- EXTERNAL DIMENSIONS
- ABSOLUTE MAXIMUM RATINGS
- ELECTRICAL CHARACTERISTICS
- TIMING OF POWER SUPPLY
- ELECTRO-OPTICAL CHARACTERISTICS
- INTERFACE PIN CONNECTIONS
- RELIABILITY TESTS
- OUTGOING QUALITY CONTROL SPECIFICATION
- CAUTIONS IN USING OLED MODULE



ASI-O-242FAYYH10/M

■ PHYSICAL DATA

No.	Items	Specification	Unit
1	Display Mode	Passive Matrix OLED	-
2	Display Color	Monochrome (Yellow)	-
3	Duty	1/64	-
4	Resolution	128(H) x 64(V)	Pixel
5	Active Area	55.01 (W) x 27.49 (H)	mm
6	Outline Dimension	60.50 (W) x 37.00 (H) x 2.00 (D)	mm
7	Pixel Pitch	0.43 (W) x 0.43 (H)	mm
8	Pixel Size	0.40 (W) x 0.40 (H)	mm
9	Driver IC	SSD1309	-
10	Interface	8-bit parallel,4-wire SPI,I2C	-
11	Weight	8.81	g



■ ABSOLUTE MAXIMUM RATINGS

Items	Symbol	Min	Typ.	Max	Unit	Notes
Supply voltage for logic	V _{DD}	-0.3	-	4	V	1,2
Supply voltage for display	V _{CC}	0	-	15.0	V	1,2
Operating temperature	T _{OP}	-40	-	70	°C	3
Storage temperature	T _{ST}	-40	-	85	°C	3
Life time(80cd/m ²)	-	150,000	-	-	hour	4
Life time(60cd/m ²)	-	200,000	-	-	hour	4
Humidity	-	-	-	90	%RH	-

Note 1: All the above voltages are on the basis of V_{SS} = 0V .

Note 2: When this module is used beyond the above absolute maximum ratings, permanent breakage of the module may occur. Also, for normal operations, it is desirable to use this module under the conditions according to electro-optical characteristics . If this module is used beyond these conditions, malfunctioning of the module can occur and the reliability of the module may deteriorate.

Note 3: The defined temperature ranges do not include the polarizer. The maximum withstood temperature of the polarizer should be 80°C.

Note 4: V_{CC} = 13.0V, T_a = 25°C, 50% Checkerboard.

Software configuration follows Actual Application Example .

End of lifetime is specified as 50% of initial brightness reached. The average operating lifetime at room temperature is estimated by the accelerated operation at high temperature conditions.



■ ELECTRICAL CHARACTERISTICS

DC Characteristics

Items	Symbol	Conditions	Min	Typ.	Max	Unit
Supply voltage for logic	V _{DD}		1.65	2.8	3.3	V
Supply voltage for display	V _{CC}	Note 5	12.5	13	13.5	V
High level input	V _{IH}	I _{OUT} = 100μA, 3.3MH	0.8 x V _{DD}	-	V _{DD}	V
Low level input	V _{IL}	I _{OUT} = 100μA, 3.3MH	0	-	0.2 x V _{DD}	V
High level output	V _{OH}	I _{OUT} = 100μA, 3.3MH	0.9 x V _{DD}	-	V _{DD}	V
Low level output	V _{OL}	I _{OUT} = 100μA, 3.3MH	0	-	0.1 x V _{DD}	V
Operating current for V _{DD}	I _{DD}		-	180	300	μA
Operating current for V _{CC}	I _{CC}	Note 6	-	16.0	20.0	mA
		Note 7	-	23.3	29.1	mA
		Note 8	-	36.2	45.3	mA
Sleep mode current for V _{DD}	I _{DD,SLEEP}		-	1	5	μA
Sleep mode current for V _{CC}	I _{CC,SLEEP}		-	2	10	μA

Note 5: Supply Voltage for Display (V_{CC}) are subject to the change of the panel characteristics and the customer's request.

Note 6: V_{DD} = 2.8V, V_{CC} = 13.0V, 30% Display Area Turn on.

Note 7: V_{DD} = 2.8V, V_{CC} = 13.0V, 50% Display Area Turn on.

Note 8: V_{DD} = 2.8V, V_{CC} = 13.0V, 100% Display Area Turn on.

* Software configuration follows Actual Application Example .

◆ AC Characteristics

1. 80XX-Series MPU Parallel Interface Timing Characteristics:

Symbol	Description	Min	Max	Unit
t_{cycle}	Clock Cycle Time	300	-	ns
t_{AS}	Address Setup Time	20	-	ns
t_{AH}	Address Hold Time	0	-	ns
t_{DW}	Data Write Time	70	-	ns
t_{DSW}	Write Data Setup Time	40	-	ns
t_{DHW}	Write Data Hold Time	15	-	ns
t_{DHR}	Read Data Hold Time	20	-	ns
t_{OH}	Output Disable Time	-	70	ns
t_{ACC}	Access Time	-	140	ns
t_{PWLR}	Read Low Time	120	-	ns
t_{PWLW}	Write Low Time	60	-	ns
t_{PWHR}	Read High Time	60	-	ns
t_{PWHW}	Write High Time	60	-	ns
t_{CS}	Chip Select Setup Time	0	-	ns
t_{CSH}	Chip Select Hold Time to Read Signal	0	-	ns
t_{CSF}	Chip Select Hold Time	20	-	ns
t_R	Rise Time	-	40	ns
t_F	Fall Time	-	40	ns

* ($V_{DD} - V_{SS} = 1.65V$ to $3.5V$, $T_a = 25^\circ C$)

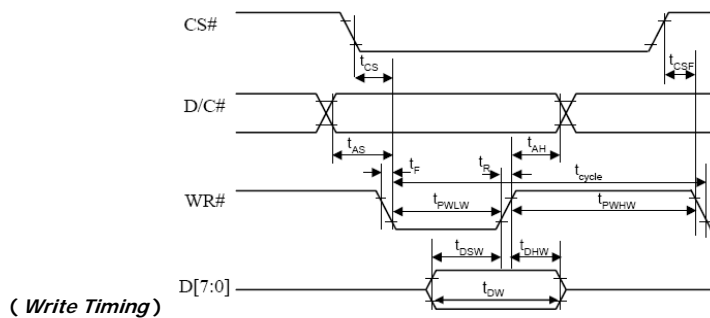
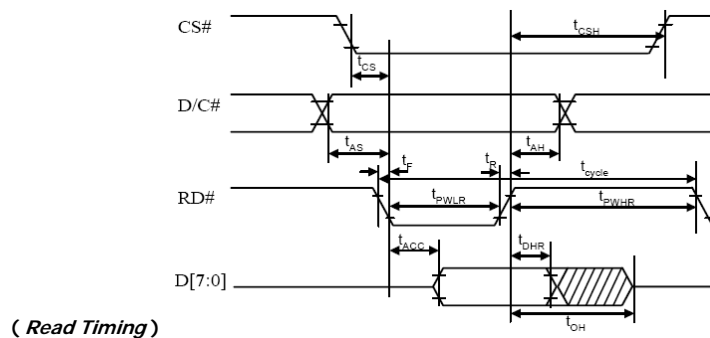

2. 68XX-Series MPU Parallel Interface Timing Characteristics:

Symbol	Description	Min	Max	Unit
t_{cycle}	Clock Cycle Time	300	-	ns
t_{AS}	Address Setup Time	20	-	ns
t_{AH}	Address Hold Time	0	-	ns
t_{DW}	Data Write Time	80	-	ns
t_{DSW}	Write Data Setup Time	40	-	ns
t_{DHW}	Write Data Hold Time	20	-	ns
t_{DHR}	Read Data Hold Time	20	-	ns
t_{OH}	Output Disable Time	-	70	ns
t_{ACC}	Access Time	-	140	ns
PW_{CSL}	Chip Select Low Pulse Width (Read)	120	-	ns
	Chip Select Low Pulse width (Write)	60		
PW_{CSH}	Chip Select High Pulse Width (Read)	60	-	ns
	Chip Select High Pulse Width (Write)	60		
t_R	Rise Time	-	40	ns
t_F	Fall Time	-	40	ns

* ($V_{DD} - V_{SS} = 1.65V$ to $3.3V$, $T_a = 25^\circ C$)

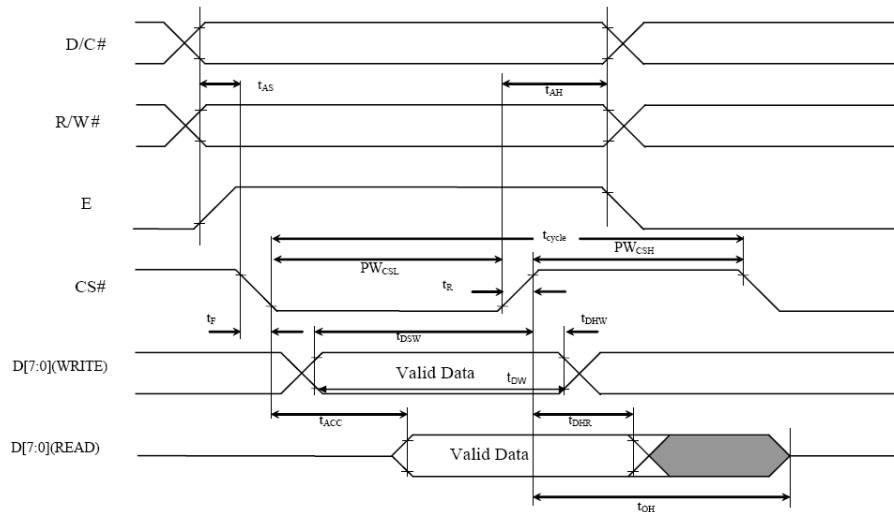

3. Serial Interface Timing Characteristics:

Symbol	Description	Min	Max	Unit
t_{cycle}	Clock Cycle Time	100	-	ns
t_{AS}	Address Setup Time	15	-	ns
t_{AH}	Address Hold Time	15	-	ns
t_{CSS}	Chip Select Setup Time	20	-	ns
t_{CSH}	Chip Select Hold Time	50	-	ns
t_{DW}	Data Write Time	55	-	ns
t_{DSW}	Write Data Setup Time	15	-	ns
t_{DHW}	Write Data Hold Time	15	-	ns
t_{CLKL}	Clock Low Time	50	-	ns
t_{CLKH}	Clock High Time	50	-	ns
t_R	Rise Time	-	40	ns
t_F	Fall Time	-	40	ns

* ($V_{DD} - V_{SS} = 1.65V$ to $3.5V$, $T_a = 25^\circ C$)

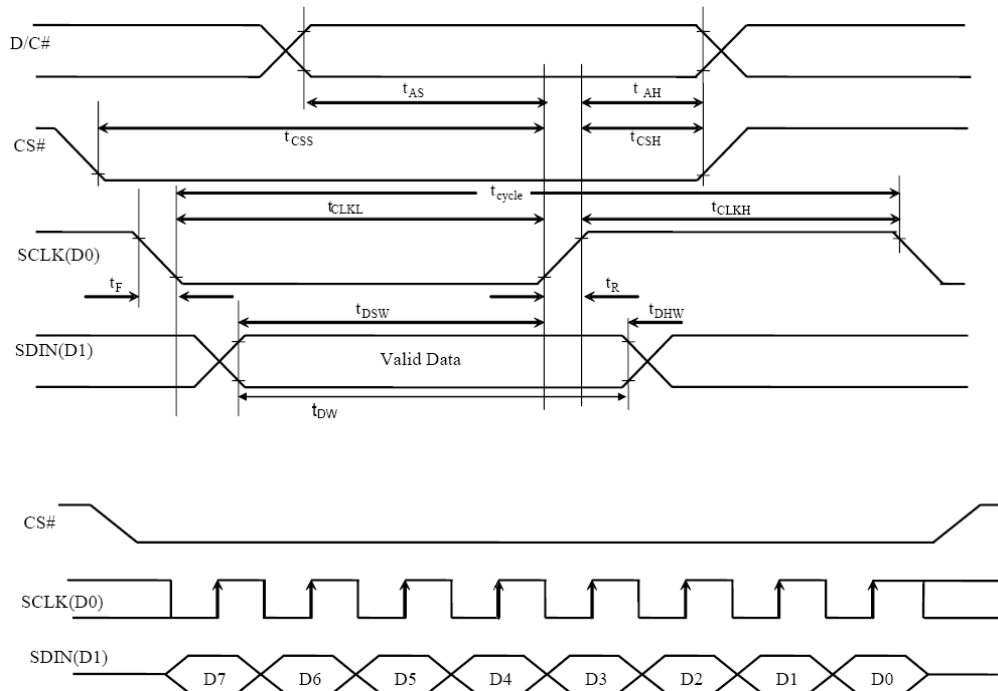

4. I²C Interface Timing Characteristics:

Symbol	Description	Min	Max	Unit
t_{cycle}	Clock Cycle Time	2.5	-	μs
t_{HSTART}	Start Condition Hold Time	0.6	-	μs
t_{HD}	Data Hold Time (for "SDA _{OUT} " Pin)	0	-	ns
	Data Hold Time (for "SDA _{IN} " Pin)	300		
t_{SD}	Data Setup Time	100	-	ns
t_{SSTART}	Start Condition Setup Time (Only relevant for a repeated Start condition)	0.6	-	μs
t_{SSTOP}	Stop Condition Setup Time	0.6	-	μs
t_{r}	Rise Time for Data and Clock Pin		300	ns
t_{f}	Fall Time for Data and Clock Pin		300	ns
t_{IDLE}	Idle Time before a New Transmission can Start	1.3	-	μs

* ($V_{\text{DD}} - V_{\text{SS}} = 1.65\text{V to } 3.5\text{V}$, $T_{\text{a}} = 25^{\circ}\text{C}$)

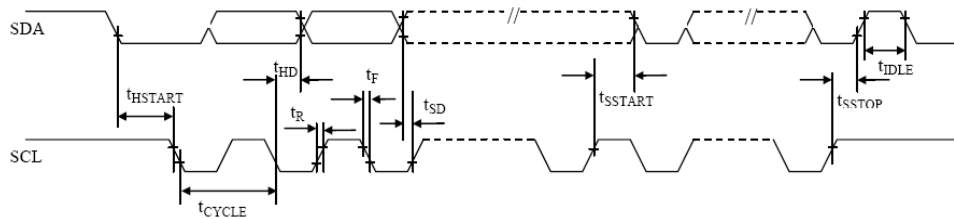

■ TIMING OF POWER SUPPLY

1. Commands

Refer to the Technical Manual for the SSD1309

2. Power down and Power up Sequence

To protect OEL panel and extend the panel life time, the driver IC power up/down routine should include a delay period between high voltage and low voltage power sources during turn on/off. It gives the OEL panel enough time to complete the action of charge and discharge before/after the operation.

2.1 Power up Sequence:

1. Power up V_{DD}
2. Send Display off command
3. Initialization
4. Clear Screen
5. Power up V_{CC}
6. Delay 100ms
(When V_{CC} is stable)
7. Send Display on command

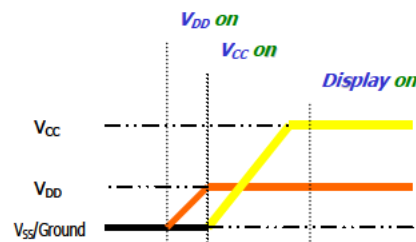

2.2 Power down Sequence:

1. Send Display off command
2. Power down V_{CC}
3. Delay 100ms
(When V_{CC} is reach 0 and panel is completely discharges)
4. Power down V_{DD}

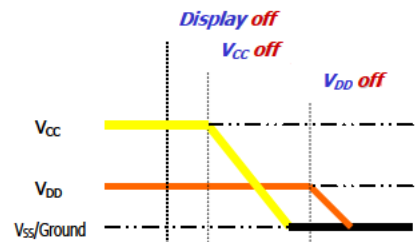

Note 9:

- 1) Since an ESD protection circuit is connected between V_{DD} and V_{CC} inside the driver IC, V_{CC} becomes lower than V_{DD} whenever V_{DD} is ON and V_{CC} is OFF.
- 2) V_{CC} should be kept float (disable) when it is OFF.
- 3) Power Pins (V_{DD} , V_{CC}) can never be pulled to ground under any circumstance.
- 4) V_{DD} should not be power down before V_{CC} power down.

3. Reset Circuit

When RES# input is low, the chip is initialized with the following status:

1. Display is OFF
2. 128×64 Display Mode
3. Normal segment and display data column and row address mapping (SEG0 mapped to column address 00h and COM0 mapped to row address 00h)
4. Shift register data clear in serial interface
5. Display start line is set at display RAM address 0
6. Column address counter is set at 0
7. Normal scan direction of the COM outputs
8. Contrast control register is set at 7Fh
9. Normal display mode (Equivalent to A4h command)

4. Actual Application Example

Command usage and explanation of an actual example

<Power up Sequence>

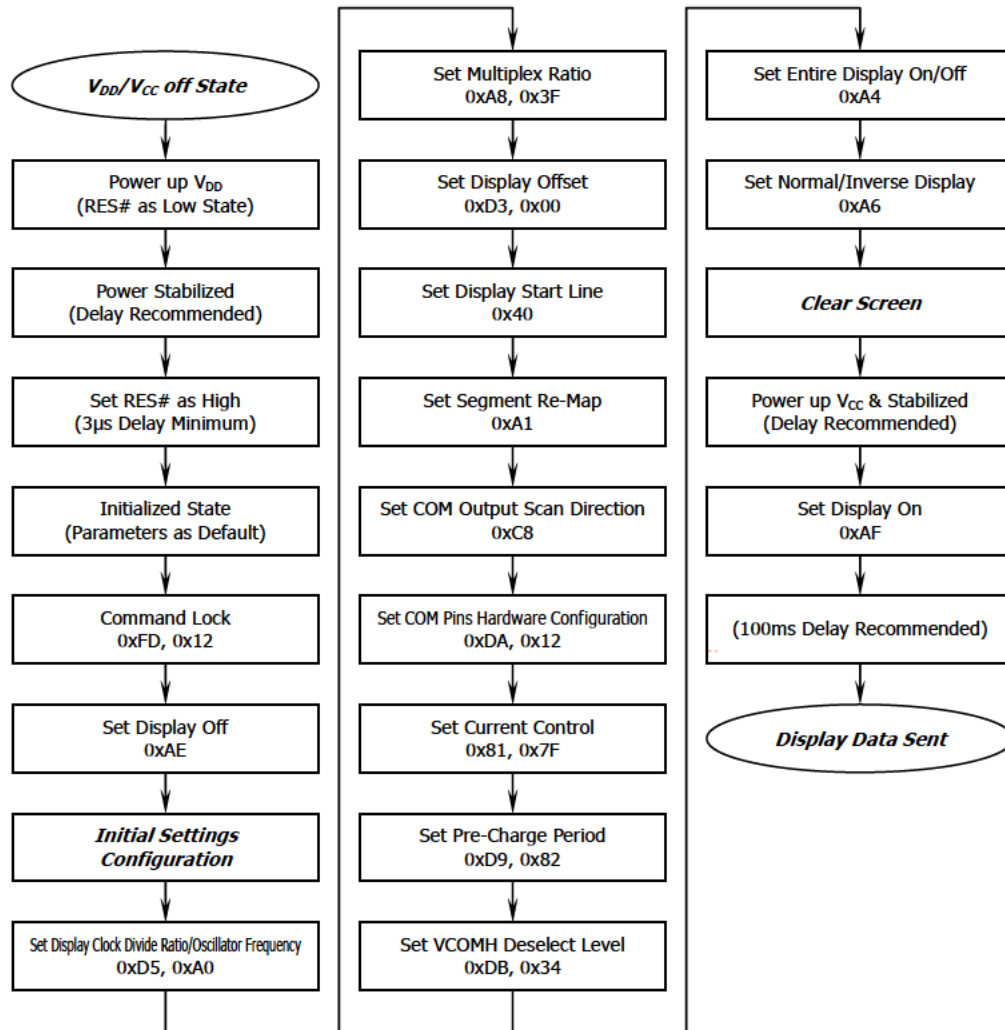

If the noise is accidentally occurred at the displaying window during the operation, please reset the display in order to recover the display function.

<Power down Sequence>

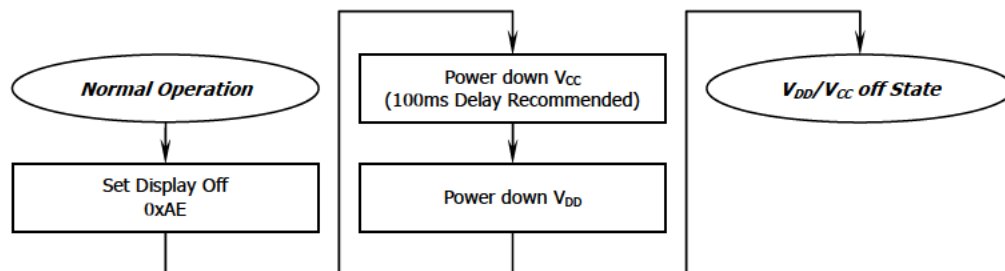

<Entering Sleep Mode>

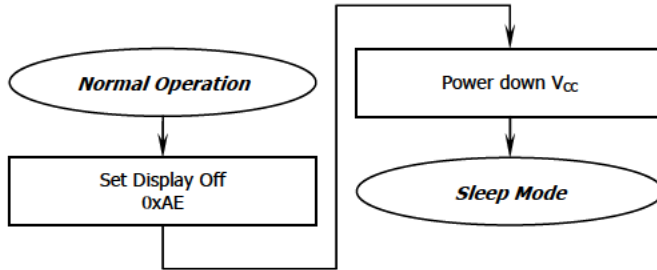

<Exiting Sleep Mode>

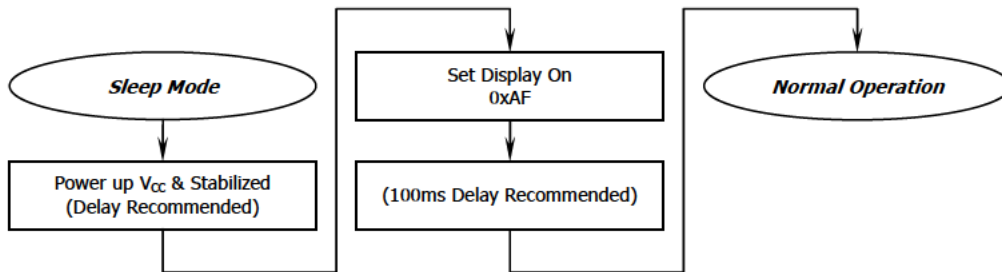



■ ELECTRO-OPTICAL CHARACTERISTICS (Ta=25°C)

Items	Symbol	Min.	Typ.	Max.	Unit	Remark	
Operating Luminance	L	60	80	-	cd /m ²	Yellow	
Power Consumption	P	-	-	-	mW	30% pixels ON L=110cd/m ²	
Frame Frequency	Fr	-	-	-	Hz		
Color Coordinate	Yellow	CIE x	0.46	0.50	0.54	CIE1931	Darkroom
		CIE y	0.45	0.49	0.53		
Response Time	Rise	Tr	-	-	-	ms	-
	Decay	Td	-	-	-	ms	-
Contrast Ratio*	Cr	10000 :1	-	-		Darkroom	
Viewing Angle Uniformity	$\Delta \theta$	-	Free	-	Degree	-	

Note : Brightness (L_{br}) is subject to the change of the panel characteristics and the customer's request.

* Optical measurement taken at V_{DD} = 2.8V, V_{CC} = 13.0V.

Software configuration follows Actual Application Example .

■ INTERFACE PIN CONNECTIONS

1. Block Diagram

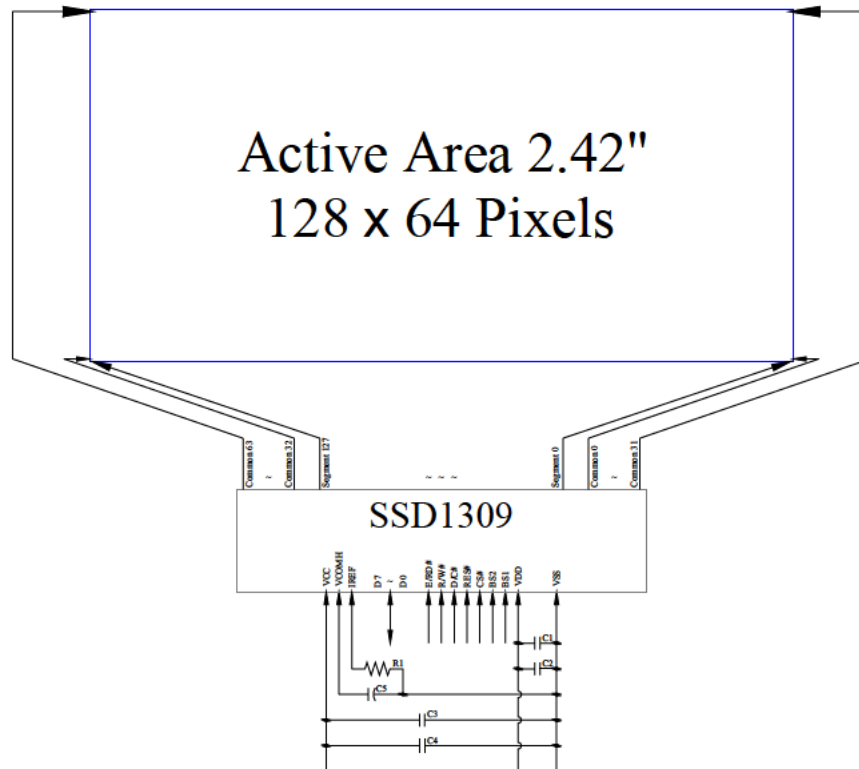

MCU Interface Selection: BS1 and BS2
 Pins connected to MCU interface: D7~D0, E/RD#, R/W#, D/C#, RES#, and CS#

C1, C3: 0.1 μ F
 C2: 4.7 μ F
 C4: 10 μ F
 C5: 4.7 μ F / 25V Tantalum Capacitor
 R1: 910k Ω , R1 = (Voltage at IREF - BGGND) / IREF

2. Pin Definition

Pin Number	Symbol	I/O	Function															
Power Supply																		
21	VDD	P	Power Supply for Logic Circuit This is a voltage supply pin. It must be connected to external source.															
30	VSS	P	Ground of OEL System This is a ground pin. It also acts as a reference for the logic pins, the OEL driving voltages, and the analog circuits. It must be connected to external ground.															
2	VCC	P	Power Supply for OEL Panel This is the most positive voltage supply pin of the chip. It must be supplied externally.															
Driver																		
4	IREF	I	Current Reference for Brightness Adjustment This pin is segment current reference pin. A resistor should be connected between this pin and V _{SS} . Set the current at 10μA.															
3	VCOMH	O	Voltage Output High Level for COM Signal This pin is the input pin for the voltage output high level for COM signals. A capacitor should be connected between this pin and V _{SS} .															
Interface																		
20 19	BS1 BS2	I	Communicating Protocol Select These pins are MCU interface selection input. See the following table: <table border="1" style="margin-left: 20px;"> <thead> <tr> <th></th> <th>BS1</th> <th>BS2</th> </tr> </thead> <tbody> <tr> <td>I²C</td> <td>1</td> <td>0</td> </tr> <tr> <td>4-wire Serial</td> <td>0</td> <td>0</td> </tr> <tr> <td>8-bit 68XX Parallel</td> <td>0</td> <td>1</td> </tr> <tr> <td>8-bit 80XX Parallel</td> <td>1</td> <td>1</td> </tr> </tbody> </table>		BS1	BS2	I ² C	1	0	4-wire Serial	0	0	8-bit 68XX Parallel	0	1	8-bit 80XX Parallel	1	1
	BS1	BS2																
I ² C	1	0																
4-wire Serial	0	0																
8-bit 68XX Parallel	0	1																
8-bit 80XX Parallel	1	1																
16	RES#	I	Power Reset for Controller and Driver This pin is reset signal input. When the pin is low, initialization of the chip is executed. Keep this pin pull high during normal operation.															
17	CS#	I	Chip Select This pin is the chip select input. The chip is enabled for MCU communication only when CS# is pulled low.															
15	D/C#	I	Data/Command Control This pin is Data/Command control pin. When the pin is pulled high, the input at D7~D0 will be interpreted as display data. When the pin is pulled low, the input at D7~D0 will be transferred to the command register. When the pin is pulled high and serial interface mode is selected, the data at SDIN will be interpreted as data. When it is pulled low, the data at SDIN will be transferred to the command register. In I ² C mode, this pin acts as SA0 for slave address selection. For detail relationship to MCU interface signals, please refer to the Timing Characteristics Diagrams.															
13	E/RD#	I	Read/Write Enable or Read This pin is MCU interface input. When interfacing to a 68XX-series microprocessor, this pin will be used as the Enable (E) signal. Read/write operation is initiated when this pin is pulled high and the CS# is pulled low. When connecting to an 80XX-microprocessor, this pin receives the Read (RD#) signal. Data read operation is initiated when this pin is pulled low and CS# is pulled low. When serial or I ² C mode is selected, this pin must be connected to V _{SS} .															
14	R/W#	I	Read/Write Select or Write This pin is MCU interface input. When interfacing to a 68XX-series microprocessor, this pin will be used as Read/Write (R/W#) selection input. Pull this pin to "High" for read mode and pull it to "Low" for write mode. When 80XX interface mode is selected, this pin will be the Write (WR#) input. Data write operation is initiated when this pin is pulled low and the CS# is pulled low. When serial or I ² C mode is selected, this pin must be connected to V _{SS} .															
5~12	D0~D7	I/O	Host Data Input/Output Bus These pins are 8-bit bi-directional data bus to be connected to the microprocessor's data bus. When serial mode is selected, D1 will be the serial data input SDIN and D0 will be the serial clock input SCLK. When I ² C mode is selected, D2, D1 should be tied together and serve as SDA _{OUT} , SDA _{IN} in application and D0 is the serial clock input, SCL. Unused pins must be connected to V _{SS} except for D2 in serial mode.															



ASI-O-242FAYYH10/M

Pin Number	Symbol	I/O	Function
Reserve			
18, 22~29	N.C.	-	Reserved Pin The N.C. pins between function pins are reserved for compatible and flexible design.
1, 31	N.C. (GND)	-	Reserved Pin (Supporting Pin) The supporting pins can reduce the influences from stresses on the function pins. These pins must be connected to external ground as the ESD protection circuit.



■ RELIABILITY TESTS

Item		Condition	Criterion
High Temperature Storage (HTS)		85±2°C, 240 hours	1. After testing, the function test is ok. 2. After testing, no addition to the defect. 3. After testing, the change of luminance should be within +/- 50% of initial value. 4. After testing, the change for the mono and area color must be within (+/-0.02, +/-0.02) and for the full color it must be within (+/-0.04, +/-0.04) of initial value based on 1931 CIE coordinates. 5. After testing, the change of total current consumption should be within +/- 50% of initial value.
High Temperature Operating (HTO)		70±2°C, 240 hours	
Low Temperature Storage (LTS)		-40±2°C, 240 hours	
Low Temperature Operating (LTO)		-40±2°C, 240 hours	
High Temperature / High Humidity Storage (HTHHS)		60±3°C, 90%±3%RH, 120 hours	
Thermal Shock (Non-operation) (TS)		-40±2°C ~ 25°C ~ 85±2°C (30min) (5min) (30min) 10cycles	
Vibration (Packing)	10~55~10Hz, amplitude 1.5mm, 1 hour for each direction x, y, z	1. One box for each test. 2. No addition to the cosmetic and the electrical defects.	
Drop (Packing)	Height : 1 m, each time for 6 sides, 3 edges, 1 angle		

Note: 1) For each reliability test, the sample quantity is 3, and only for one test item.
 2) The HTHHS test is requested the Pure Water(Resistance > 10MΩ).

■ OUTGOING QUALITY CONTROL SPECIFICATION

◆ Standard

According to GB/T2828.1-2003/ISO 2859-1: 1999 and ANSI/ASQC Z1.4-1993, General Inspection Level II.

◆ Definition

- 1 Major defect : The defect that greatly affect the usability of product.
- 2 Minor defect : The other defects, such as cosmetic defects, etc.
- 3 Definition of inspection zone:

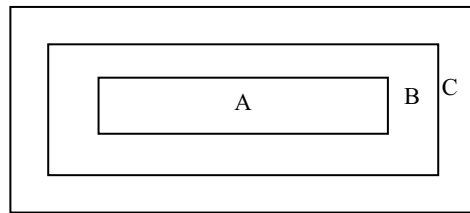

Zone A: Active Area

Zone B: Viewing Area except Zone A

Zone C: Outside Viewing Area

Note: As a general rule, visual defects in Zone C are permissible, when it is no trouble of quality and assembly to customer`s product.

◆ Inspection Methods

- 1 The general inspection : under 20W x 2 or 40W fluorescent light, about 30cm viewing distance, within 45° viewing angle, under 25±5°C.

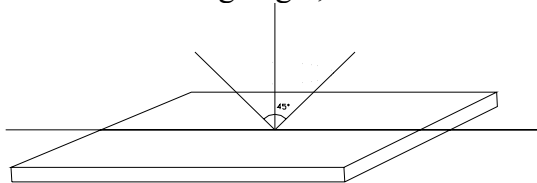

- 2 The luminance and color coordinate inspection : By PR705 or BM-7 or the equal equipments, in the dark room, under 25±5°C.

◆ Inspection Criteria

- 1 Major defect : AQL 0.65

Item	Criterion
Function Defect	1. No display or abnormal display is not accepted
	2. Open or short is not accepted.
	3. Power consumption exceeding the spec is not accepted.
Outline Dimension	Outline dimension exceeding the spec is not accepted.
Glass Crack	Glass crack tends to enlarge is not accepted.

- 2 Minor Defect : AQL 1.5

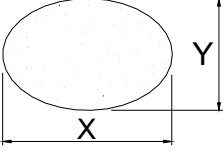
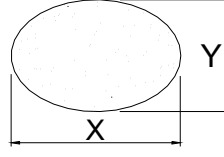
Item	Criterion			
Spot Defect (dimming and lighting spot)	Size (mm)		Accepted Qty	
			Area A + Area B	Area C
		$\Phi \leq 0.10$	Ignored	
		$0.10 < \Phi \leq 0.15$	3	Ignored
		$0.15 < \Phi \leq 0.20$	1	
$0.20 < \Phi$		0		
Note : $\Phi = (x + y) / 2$				
Line Defect (dimming and lighting line)	L (Length) : mm	W (Width) : mm	Area A + Area B	Area C
	/	$W \leq 0.03$	Ignored	
	$L \leq 3.0$	$0.03 < W \leq 0.05$	2	Ignored
	$L \leq 2.0$	$0.05 < W \leq 0.08$	1	
	/	$0.08 < W$	As spot defect	
Remarks: The total of spot defect and line defect shall not exceed 4 pcs.				
Polarizer Stain	Stain which can be wiped off lightly with a soft cloth or similar cleaning is accepted, otherwise, according to the Spot Defect and the Line Defect.			
Polarizer Scratch	1. If scratch can be seen during operation, according to the criterions of the Spot Defect and the Line Defect.			
	2. If scratch can be seen only under non-operation or some special angle, the criterion is as below :			
	L (Length) : mm	W (Width) : mm	Area A + Area B	Area C
	/	$W \leq 0.03$	Ignore	
	$5.0 < L \leq 10.0$	$0.03 < W \leq 0.05$	2	Ignore
	$L \leq 5.0$	$0.05 < W \leq 0.08$	1	
/	$0.08 < W$	0		
Polarizer Air Bubble	Size		Area A + Area B	Area C
		$\Phi \leq 0.20$	Ignored	
		$0.20 < \Phi \leq 0.50$	2	Ignored
		$0.50 < \Phi \leq 0.80$	1	
		$0.80 < \Phi$	0	

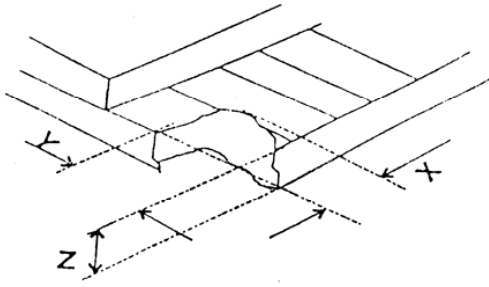
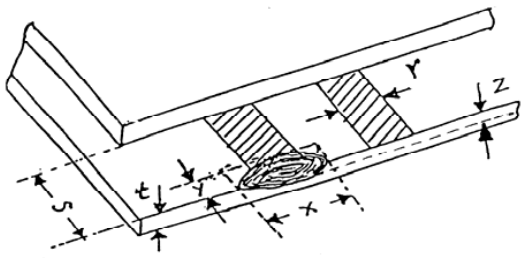
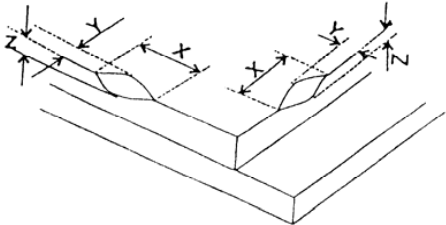
Glass Defect (Glass Chipped)	1. On the corner	(mm)						
		<table border="1"> <tr> <td>x</td> <td>≤ 2.0</td> </tr> <tr> <td>y</td> <td>$\leq S$</td> </tr> <tr> <td>z</td> <td>$\leq t$</td> </tr> </table>	x	≤ 2.0	y	$\leq S$	z	$\leq t$
	x	≤ 2.0						
	y	$\leq S$						
z	$\leq t$							
2. On the bonding edge	(mm)							
	<table border="1"> <tr> <td>x</td> <td>$\leq a / 2$</td> </tr> <tr> <td>y</td> <td>$\leq s / 3$</td> </tr> <tr> <td>z</td> <td>$\leq t$</td> </tr> </table>	x	$\leq a / 2$	y	$\leq s / 3$	z	$\leq t$	
x	$\leq a / 2$							
y	$\leq s / 3$							
z	$\leq t$							
3. On the other edges	(mm)							
	<table border="1"> <tr> <td>x</td> <td>$\leq a / 5$</td> </tr> <tr> <td>y</td> <td>≤ 1.0</td> </tr> <tr> <td>z</td> <td>$\leq t$</td> </tr> </table>	x	$\leq a / 5$	y	≤ 1.0	z	$\leq t$	
x	$\leq a / 5$							
y	≤ 1.0							
z	$\leq t$							
Note: t: glass thickness ; s: pad width ; a: the length of the edge								
TCP Defect	Crack, deep fold and deep pressure mark on the TCP are not accepted							
Pixel Size	The tolerance of display pixel dimension should be within $\pm 20\%$ of the spec							
Luminance	Refer to the spec or the reference sample							
Color	Refer to the spec or the reference sample							



■ CAUTIONS IN USING OLED MODULE

◆ Precautions For Handling OLED Module:

1. OLED module consists of glass and polarizer. Pay attention to the following items when handling:
 - i. Avoid drop from high, avoid excessive impact and pressure.
 - ii. Do not touch, push or rub the exposed polarizers with anything harder than an HB pencil lead.
 - iii. If the surface becomes dirty, breathe on the surface and gently wipe it off with a soft dry cloth. If it is terrible dirty, moisten the soft cloth with Isopropyl alcohol or Ethyl alcohol. Other solvents may damage the polarizer. Especially water, Ketone and Aromatic solvents.
 - iv. Wipe off saliva or water drops immediately, contact the polarizer with water over a long period of time may cause deformation.
 - v. Please keep the temperature within specified range for use and storage. Polarization degradation, bubble generation or polarizer peeling-off may occur with high temperature and high humidity.
 - vi. Condensation on the surface and the terminals due to cold or anything will damage, stain or dirty the polarizer, so make it clean as the way of iii.
2. Do not attempt to disassemble or process the OLED Module.
3. Make sure the TCP or the FPC of the Module is free of twisting, warping and distortion, do not pull or bend them forcefully, especially the soldering pins. On the other side, the SLIT part of the TCP is made to bend in the necessary case.
4. When assembling the module into other equipment, give the glass enough space to avoid excessive pressure on the glass, especially the glass cover which is much more fragile.
5. Be sure to keep the air pressure under 120 kPa, otherwise the glass cover is to be cracked.
6. Be careful to prevent damage by static electricity:
 - i. Be sure to ground the body when handling the OLED Modules.
 - ii. All machines and tools required for assembling, such as soldering irons, must be properly grounded.
 - iii. Do not assemble and do no other work under dry conditions to reduce the amount of static electricity generated. A relative humidity of 50%-60% is recommended.
 - iv. Peel off the protective film slowly to avoid the amount of static electricity generated.
 - v. Avoid to touch the circuit, the soldering pins and the IC on the Module by the body.
 - vi. Be sure to use anti-static package.
7. Contamination on terminals can cause an electrochemical reaction and corrode the terminal circuit, so make it clean anytime.
8. All terminals should be open, do not attach any conductor or semiconductor on the terminals.
9. When the logic circuit power is off, do not apply the input signals.
10. Power on sequence: $V_{DD} \rightarrow V_{PP}$, and power off sequence: $V_{PP} \rightarrow V_{DD}$.
11. Be sure to keep temperature, humidity and voltage within the ranges of the spec, otherwise shorten Module's life time, even make it damaged.
12. Be sure to drive the OLED Module following the Specification and Datasheet of IC controller, otherwise something wrong may be seen.



ASI-O-242FAYYH10/M

13. When displaying images, keep them rolling, and avoid one fixed image displaying more than 30 seconds, otherwise the residue image is to be seen. This is the speciality of OLED.

◆ **Precautions For Soldering OLED Module:**

1. Soldering temperature : $260^{\circ}\text{C} \pm 10^{\circ}\text{C}$.
2. Soldering time : 3-4 sec.
3. Repeating time : no more than 3 times.
4. If soldering flux is used, be sure to remove any remaining flux after finishing soldering operation. (This does not apply in the case of a non-halogen type of flux.) It is recommended to protect the surface with a cover during soldering to prevent any damage due to flux spatters.

◆ **Precautions For Storing OLED Module:**

1. Be sure to store the OLED Module in the vacuum bag with dessicant.
2. If the Module can not be used up in 1 month after the bag being opened, make sure to seal the Module in the vacuum bag with dessicant again.
3. Store the Module in a dark place, do not expose to sunlight or fluorescent light.
4. The polarizer surface should not touch any other objects. It is recommended to store the Module in the shipping container.
5. It is recommended to keep the temperature between 0°C and 30°C , the relative humidity not over 60%.

◆ **Limited Warranty**

Unless relevant quality agreements signed with customer and law enforcement, for a period of 12 months from date of production, all products (except automotive products) All Shore will replace or repair any of its OLED modules which are found to be functional defect when inspected in accordance with All Shore OLED acceptance standards (copies available upon request). Cosmetic/visual defects must be returned to All Shore within 90 days of shipment. Confirmation of such date should be based on freight documents. The warranty liability of All Shore is limited to repair and/or replacement on the terms above. All Shore will not be responsible for any subsequent or consequential events.

◆ **Return OLED Module Under Warranty:**

1. No warranty in the case that the precautions are disregarded.
2. Module repairs will be invoiced to the customer upon mutual agreement. Modules must be returned with sufficient description of the failures or defects.