

ALL SHORE INDUSTRIES

ASI-T-240DA10SMN/AQ

Item	Standard Value	Unit
Display Size	2.4"	--
Number of Pixels	240(H)x3(RGB)*320(V)	--
Active Area	36.72(H) *48.96(V)	mm
Outline Dimension	42.72(H) ×60.26(V)× 2.20(D)	mm
Viewing Direction	FULL O'Clock	-
Interface	MCU 8/16 bit interface compatible with SPI 3L/4L	-
Driver IC	ST7789V	-
Driver Condition	IOVCC=1.8V,VCI=2.8V	V
Backlight	White LED	-
Touch Panel	No Touch Panel	-
TFT Operation Temperature	-30~80	°C
TFT Storage Temperature	-40~80	°C



1 Document revision history :

DOCUMENT REVISION	DATE	DESCRIPTION	PREPARED BY	APPROVED BY
0	2021-06-01	First Release.	Liu.YL	

1. General Feature:

Item	Standard Value	Unit
Display Size	2.4"	--
Number of Pixels	240(H)x3(RGB)*320(V)	--
Active Area	36.72(H) *48.96(V)	mm
Outline Dimension	42.72(H) ×60.26(V)× 2.20(D)	mm
Viewing Direction	FULL O'Clock	-
Interface	MCU 8/16 bit interface compatible with SPI 3L/4L	-
Driver IC	ST7789V	-
Driver Condition	IOVCC=1.8V,VCI=2.8V	V
Backlight	White LED	-
Touch Panel	No Touch Panel	-
TFT Operation Temperature	-30~80	°C
TFT Storage Temperature	-40~80	°C

2. Outline Dimensions

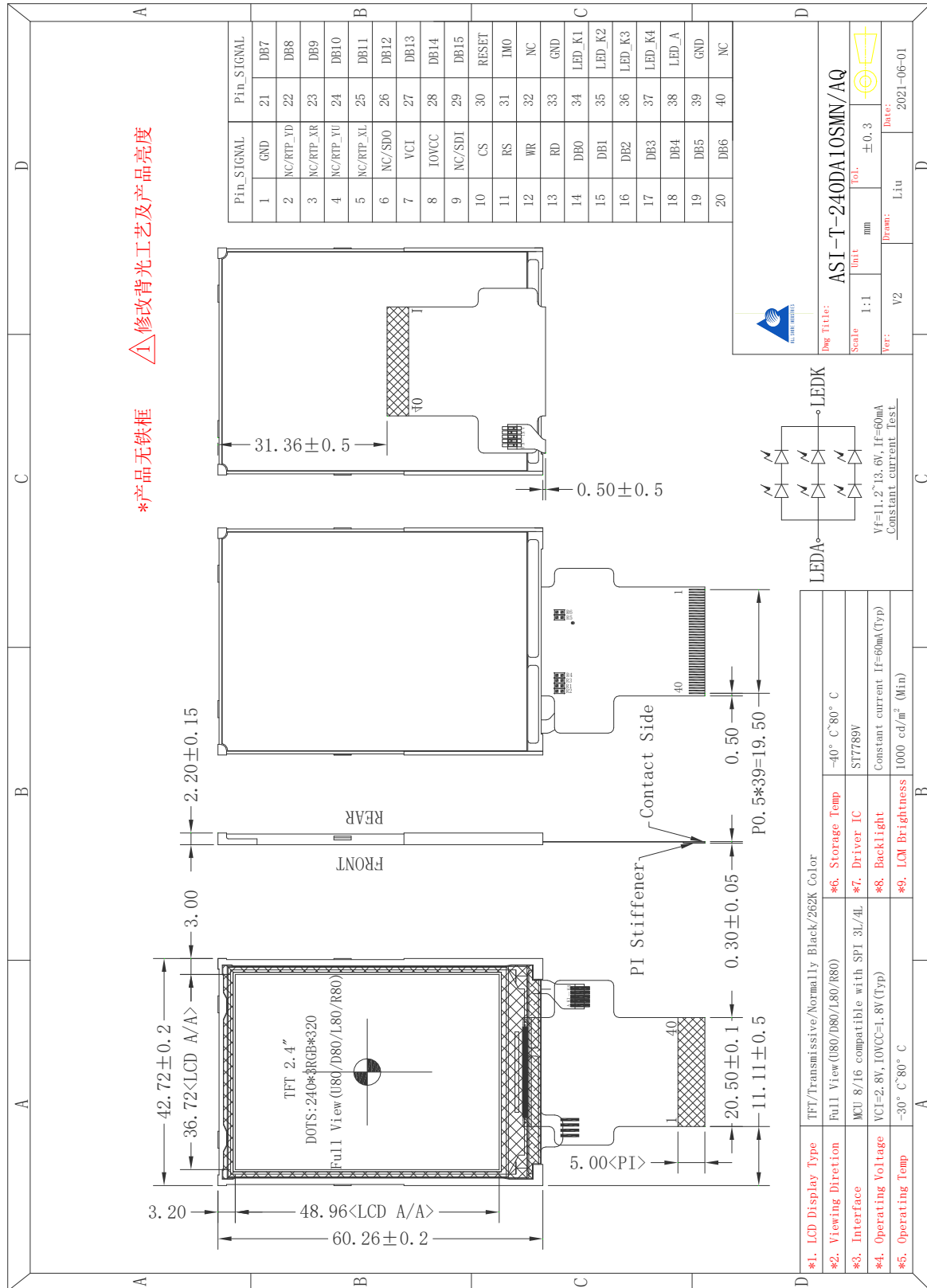

3. Pin Description

3.1 Pin Description

Pin NO.	Symbol	Description
1	GND	Ground
2	NC/RTP_YD	Resistive TP function pin.If not used, let this pin open.
3	NC/RTP_XR	
4	NC/RTP_YU	
5	NC/RTP_XL	
6	NC/SDO	SPI interface output pin.If not used, let this pin open.
7	VCI	Analog Power(2.65 ~ 3.3 V)
8	IOVCC	Logic Power(1.75 ~ 3.3 V)
9	NC/SDI	SPI interface input pin.If not used, let this pin open.
10	CS	Chip select input pin (“Low” enable).
11	RS	◆Display data/command selection pin in parallel interface. ◆This pin is used to be serial interface clock.
12	WR	◆Write enable in MCU parallel interface ◆Display data/command selection pin in 4-line serial interface.
13	RD	Read enable in 8080 MCU parallel interface.If not used, please fix this pin at GND.
14-21	DB0-DB7	Data Bus.If not used, please fix this pin at GND.
22-29	DB8-DB15	
30	RESET	Reset Pin
31	IM0	IM0=GND: 16-bit i80;IM0=IOVCC: 8-bit i80
32	NC	No Connector
33	GND	Ground
34	LED_K1	LED Cathode
35	LED_K2	
36	LED_K3	
37	LED_K4	
38	LED_A	LED Anode
39	GND	Ground
40	NC	No Connector
---END---		

3.2 Wiring Diagram

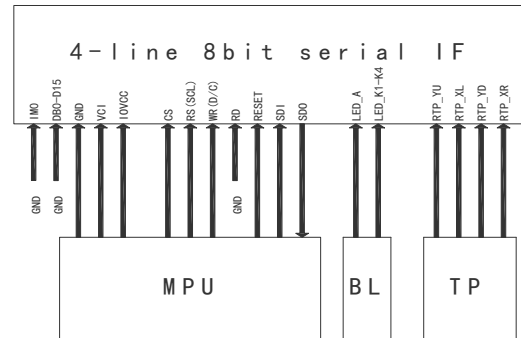
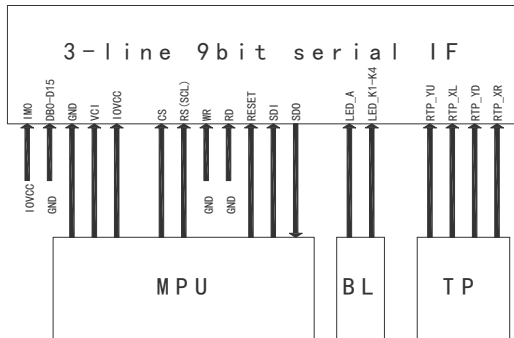
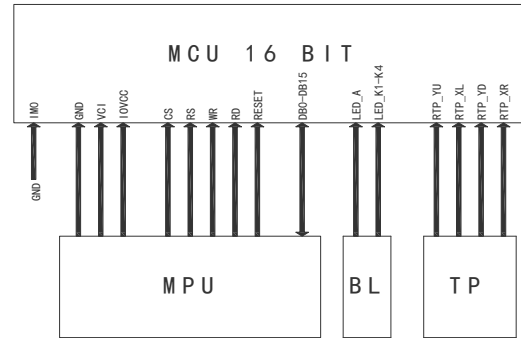
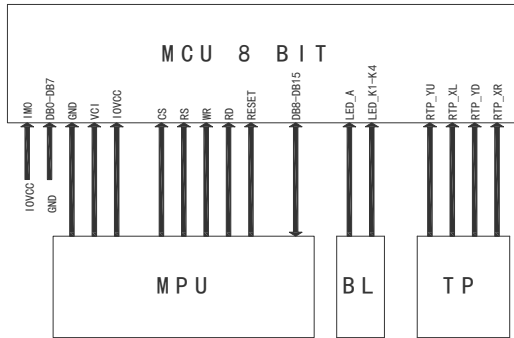

* Also need to change the resistance position on the FPC to: R1, R4, R6

* Also need to change the resistance position on the FPC to: R2, R4, R6

4. Electrical Characteristics

4-1 TFT LCD Module Operating Conditions

Item	Symbol	Condition	Min	Type	Max	Unit
Interface logic circuits	IOVCC	-	1.65	1.80	3.30	V
Analog Power supply	VCI	-	2.50	2.80	3.30	V
TFT Gate on voltage	VGH	-	10.0	-	16.0	V
TFT Gate off voltage	VGL	-	-16.0	-	-10.0	V

4-2 LED back light specification (pera chip)

Item	Symbol	Condition	Min	Type	Max	Unit
Forward voltage	Vt	If=20mA	11.2	-	13.6	V
Forward current	Ipn	/1-chip	-	60	-	mA
Luminance(With LCD)	Lv	If=60mA	1000	-	-	cd/m ²
Luminous color	White					

5.OPTICAL SPECIFICATION

5.1 Overview

The test of Optical specifications shall be measured in a dark room (ambient luminance 1lux and temperature = 25 ± 2°C) with the equipment of Luminance meter system (Goniometer system and TOPCON BM-5) and test unit shall be located at an approximate distance 50cm from the LCD surface at a viewing angle of θ and Φ equal to 0°. The center of the measuring spot on the Display surface shall stay fixed. The backlight should be operating for 30 minutes prior to measurement.

5.2 Optical Specifications

Parameter		Symbol	Condition	Min.	Typ.	Max.	Unit	Remark
Viewing Angle Range	Horizontal	Θ 3	CR>10	70	80	-	Deg.	Note 1
		Θ 9		70	80	-	Deg.	
	Vertical	Θ 12		70	80	-	Deg.	
		Θ 6		70	80	-	Deg.	
Contrast ratio		CR	$\Theta = 0^\circ$	1000	1500	-		Note2
Color Gamut		CG		65	70		%	
White Chromaticity		Wx	$\Theta = 0^\circ$	0.287	0.307	0.327		
		Wy		0.314	0.334	0.354		
Reproduction of color	Red	Rx	$\Theta = 0^\circ$	0.632	0.652	0.672		Note4 (Based on C Light)
		Ry		0.302	0.322	0.342		
	Green	Gx		0.256	0.276	0.296		
		Gy		0.562	0.582	0.602		
	Blue	Bx		0.121	0.141	0.161		
		By		0.071	0.091	0.111		
Response Time (Rising + Falling)		Tr+Tf	$\Theta = 0^\circ$ Ta= 25°C	-	35	45	ms	Note5
Transmittance		Tr		4.0	4.65		%	Note3

Note:

1.Viewing angle is the angle at which the contrast ratio is greater than 10. The viewing angles are determined for the horizontal or 3, 9 o' clock direction and the vertical or 6, 12 o' clock direction with respect to the optical axis which is normal to the LCD surface (see FIGURE 1).

2.Contrast measurements shall be made at viewing angle of $\Theta = 0$ and at the center of the LCD surface. Luminance shall be measured with all pixels in the view field set first to white, then to the dark (black)

state . (see FIGUR 1) Luminance Contrast Ratio (CR) is defined mathematically.

$$CR = \frac{\text{Luminance when displaying a white raster}}{\text{Luminance when displaying a black raster}}$$

3. Transmittance is the Value without APF and without CG.

4. The color chromaticity coordinates specified in the above table shall be calculated from the spectral data measured with all pixels first in red, green, blue and white. Measurements shall be made at the center of the panel.

5. The electro-optical response time measurements shall be made as FIGURE 2 by switching the “data” input signal ON and OFF. The times needed for the luminance to change from 10% to 90% is T_r , and 90% to 10% is T_f .

Figure1 Measurement Set Up

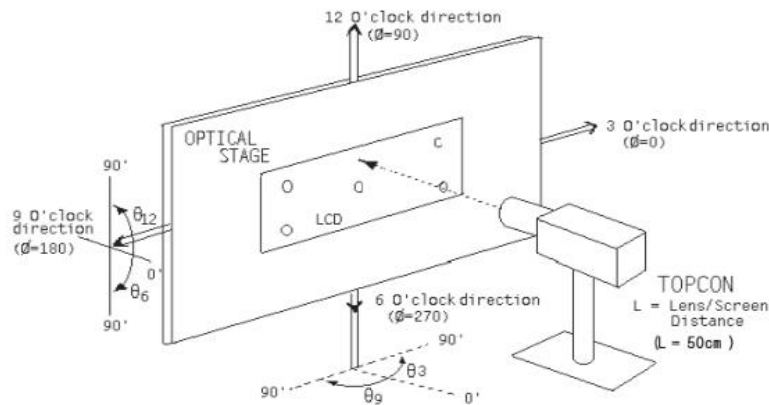
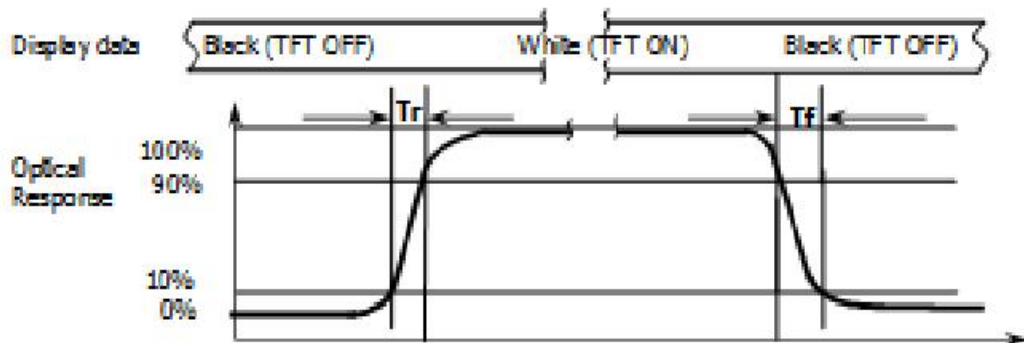
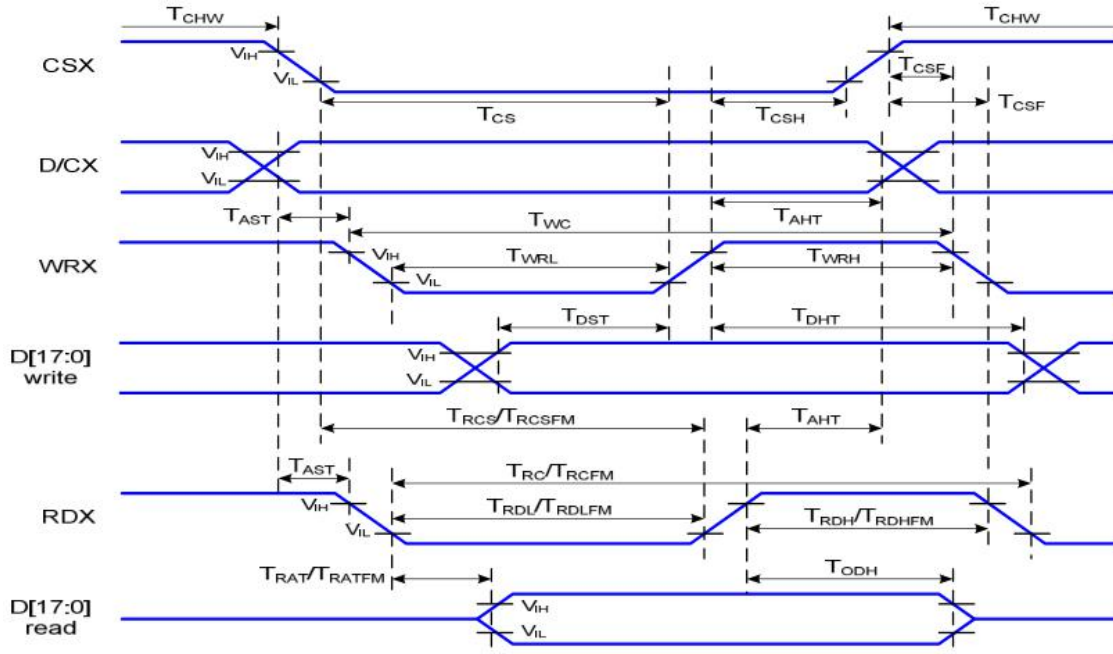

Figure2 Response Time Testing



6. Timing Characteristics of Input Signals

6-1 Display Parallel 16/8 bit Interface Timing Characteristics



VDD1=1.65 to 3.3V, VDD=2.4 to 3.3V, AGND=DGND=0V, Ta=25°C

Signal	Symbol	Parameter	Min	Max	Unit	Description
D/CX	T _{AST}	Address setup time	0		ns	-
	T _{AHT}	Address hold time (Write/Read)	10		ns	
CSX	T _{CHW}	Chip select "H" pulse width	0		ns	-
	T _{CS}	Chip select setup time (Write)	15		ns	
	T _{RCS}	Chip select setup time (Read ID)	45		ns	
	T _{RCSFM}	Chip select setup time (Read FM)	355		ns	
	T _{CSF}	Chip select wait time (Write/Read)	10		ns	
	T _{CSH}	Chip select hold time	10		ns	
WRX	T _{WC}	Write cycle	66		ns	-
	T _{WRH}	Control pulse "H" duration	15		ns	
	T _{WRL}	Control pulse "L" duration	15		ns	
RDX (ID)	T _{RC}	Read cycle (ID)	160		ns	When read ID data
	T _{RDH}	Control pulse "H" duration (ID)	90		ns	
	T _{RDL}	Control pulse "L" duration (ID)	45		ns	
RDX (FM)	T _{RCFM}	Read cycle (FM)	450		ns	When read from frame memory
	T _{RDHFM}	Control pulse "H" duration (FM)	90		ns	
	T _{RDLFM}	Control pulse "L" duration (FM)	355		ns	
D[17:0]	T _{DST}	Data setup time	10		ns	For CL=30pF
	T _{DHT}	Data hold time	10		ns	
	T _{RAT}	Read access time (ID)		40	ns	
	T _{RATFM}	Read access time (FM)		340	ns	
	T _{ODH}	Output disable time	20	80	ns	

6-2 Serial Interface Characteristics (3-line serial)

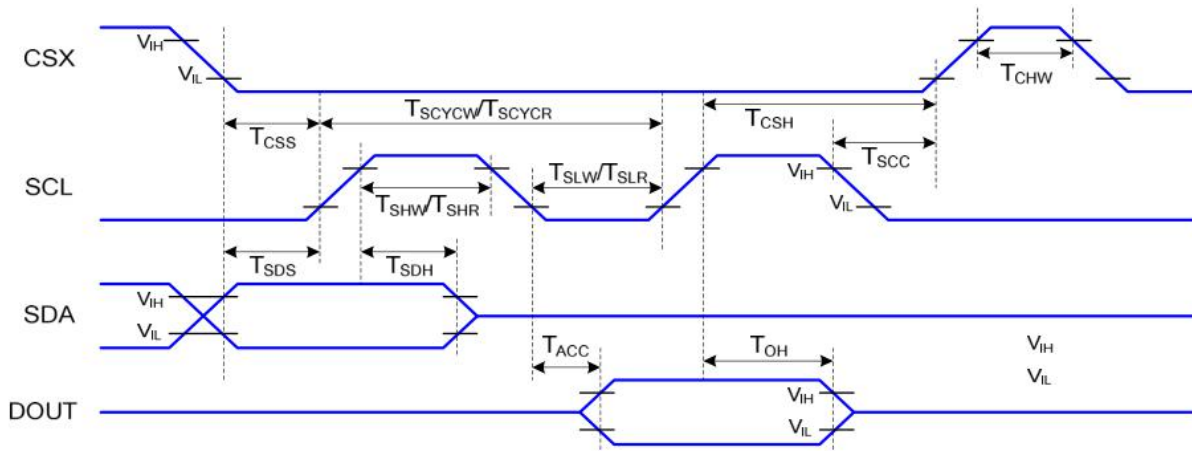

$V_{DDI}=1.65$ to $3.3V$, $V_{DD}=2.4$ to $3.3V$, $AGND=DGND=0V$, $T_a=25^{\circ}C$

Signal	Symbol	Parameter	Min	Max	Unit	Description
CSX	T_{CSS}	Chip select setup time (write)	15		ns	
	T_{CSH}	Chip select hold time (write)	15		ns	
	T_{CSS}	Chip select setup time (read)	60		ns	
	T_{SCC}	Chip select hold time (read)	65		ns	
	T_{CHW}	Chip select "H" pulse width	40		ns	
SCL	T_{SCYCW}	Serial clock cycle (Write)	66		ns	
	T_{SHW}	SCL "H" pulse width (Write)	15		ns	
	T_{SLW}	SCL "L" pulse width (Write)	15		ns	
	T_{SCYCR}	Serial clock cycle (Read)	150		ns	
	T_{SHR}	SCL "H" pulse width (Read)	60		ns	
	T_{SLR}	SCL "L" pulse width (Read)	60		ns	
SDA (DIN)	T_{SDS}	Data setup time	10		ns	
	T_{SDH}	Data hold time	10		ns	
DOUT	T_{ACC}	Access time	10	50	ns	For maximum $CL=30pF$
	T_{OH}	Output disable time	15	50	ns	For minimum $CL=8pF$

6-3 Serial Interface Characteristics (4-line serial)

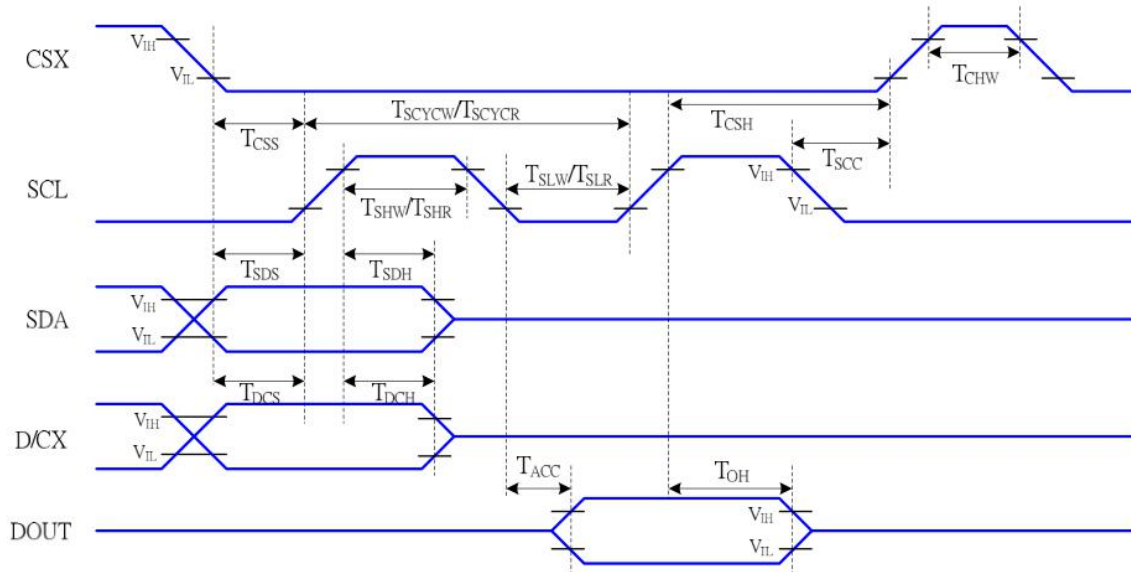

VDDI=1.65 to 3.3V, VDD=2.4 to 3.3V, AGND=DGND=0V, Ta=25°C

Signal	Symbol	Parameter	MIN	MAX	Unit	Description
CSX	T _{CSS}	Chip select setup time (write)	15		ns	
	T _{CSH}	Chip select hold time (write)	15		ns	
	T _{CSS}	Chip select setup time (read)	60		ns	
	T _{SCC}	Chip select hold time (read)	65		ns	
	T _{CHW}	Chip select "H" pulse width	40		ns	
SCL	T _{SCYCW}	Serial clock cycle (Write)	66		ns	-write command & data ram
	T _{SHW}	SCL "H" pulse width (Write)	15		ns	
	T _{SLW}	SCL "L" pulse width (Write)	15		ns	
	T _{SCYCR}	Serial clock cycle (Read)	150		ns	-read command & data ram
	T _{SHR}	SCL "H" pulse width (Read)	60		ns	
	T _{SLR}	SCL "L" pulse width (Read)	60		ns	
D/CX	T _{DCS}	D/CX setup time	10		ns	
	T _{DCH}	D/CX hold time	10		ns	
SDA (DIN)	T _{SDS}	Data setup time	10		ns	
	T _{SDH}	Data hold time	10		ns	
DOUT	T _{ACC}	Access time	10	50	ns	For maximum CL=30pF
	T _{OH}	Output disable time	15	50	ns	For minimum CL=8pF

7. RELIABILITY TEST

7-1 Temperature and Humidity

TEST ITEMS	CONDITIONS	NOTE
High Temperature Operation	80°C ; 120hrs	
High Temperature Storage	80°C ; 120hrs	
High Temperature High Humidity Operation	60°C; 90%RH ; 120hrs (No condensation)	
Low Temperature Operation	-30°C ; 120hrs	
Low Temperature Storage	-30°C ; 120hrs	
Thermal Shock Test	-40°C (0.5hr) ~ 85°C (0.5hr) ; 100 Cycles	Non-Operating

7-2 Shock and Vibration

ITEMS	CONDITIONS
Packing Shock (Non-Operation)	<ul style="list-style-type: none"> ● Shock level:980m/s² ● Waveform:1/2 Sine wave,6msec ● ±X, ±Y ±Z,each axis 1 times
Packing Vibration (Non-Operation)	<ul style="list-style-type: none"> ● Frequency range:8-33.3HZ ● Stoke:1.0mm ● Sweep: 10Hz-50Hz ● x,y,z 2 hours for each direction

7-3 Electrostatic Discharge

TEST ITEM	CONDITIONS
ESD (Non-operation)	150pF,330 Ω , Contact±4KV,Air :±8KV.Note 1
	200pF,0 Ω , ±200V Contact test.Note 2

Note:Measure Point:

- 1.LCD glass and metal bezel
- 2.IF connector pins

8.HANDDLING & CAUTIONS

8-1 Caution For Operation

◆Since the LCM is made of glass, do not apply strong mechanical impact or static load onto it. Handling with care since shock, vibration, and careless handling may seriously affect the product. If it falls from a high place or receives a strong shock, the glass maybe broken.

◆It is indispensable to drive the LCM within the specified voltage limit since the higher voltage than the limit causes LCM's life shorter. An electro-chemical reaction due to DC causes undesirable deterioration of the LCM so that the use of DC drive should avoid.

◆Do not connect or disconnect the LCM to or from the system when power is on.

◆Never use the LCM under abnormal conditions of high temperature and high humidity.

◆When expose to drastic fluctuation of temperature(hot to cold or cold to hot), the LCM may be affected; specifically, drastic temperature fluctuation from cold to hot, produces dew on the LCM's surface which may affect the operation of the polarizer on the LCM.

◆Response time will be extremely delay at lower temperature than the operating temperature range and on the other hand LCM may turn black at temperature above its operational range. However those phenomenon do not mean malfunction or out of order with the LCM. The LCM will revert to normal operation once the temperature returns to the recommended temperature range for normal operation.

◆Do not disassemble and/or re-assemble LCM module

7-2 Caution Against Static Charge

◆The LCM use C-MOS LSI drivers, so customers are recommended that any unused input terminal would be connected to Vdd or Vss, do not input any signals before power is turn on, and ground you body, work/assembly area, assembly equipments to protect against static electricity.

◆Remove the protective film slowly, keeping the removing direction approximate 30-degree not vertical from panel surface, if possible, under ESD control device like ion blower, and the humidity of working room should be kept over 50%RH to reduce the risk of static charge.

◆Avoid the use work clothing made of synthetic fibers. We recommend cotton clothing or other conductivity-treated fibers.

◆In handling the LCM, wear non-charged material gloves. And the conducting wrist to the earth and the conducting shoes to the earth are necessary

9.LCD display initialization code

```

Void Panel_initial_code(void)
{
    //-----Reset sequence-----//
    LCD_RESET=1;
    Delaysms(1); //Delay 1ms
    LCD_RESET=0;
    Delaysms(10); //Delay 10ms
    LCD_RESET=1;
    Delaysms(120); //Delay 120ms
    //-----//
    WriteComm(0x11);
    Delay(120); //Delay 120ms
    //-----Display Setting-----//
    WriteComm(0x21);
    WriteComm(0x36);
    WriteData(0x00);
    WriteComm(0x3a);
    WriteData(0x05);
    //-----Frame rate setting-----//
    WriteComm(0xb2);
    WriteData(0x0c);
    WriteData(0x0c);
    WriteData(0x00);
    WriteData(0x33);
    WriteData(0x33);
    WriteComm(0xb7);
    WriteData(0x35);
    //-----Power setting-----//
    WriteComm(0xbb);
    WriteData(0x21); //20
    WriteComm(0xc0);
    WriteData(0x2c);
    WriteComm(0xc2);
    WriteData(0x01);
    WriteComm(0xc3);
    WriteData(0x0b);
    WriteComm(0xc4);

    WriteData(0x20);

```



```
WriteComm(0xc6);
WriteData(0x0f);
WriteComm(0xd0);
WriteData(0xa4);
WriteData(0xa1);
//-----gamma setting-----//
WriteComm(0xe0);
WriteData(0xD0);
WriteData(0x06);
WriteData(0x0B);
WriteData(0x09);
WriteData(0x08);
WriteData(0x30);
WriteData(0x30);
WriteData(0x5B);
WriteData(0x4B);
WriteData(0x18);
WriteData(0x14);
WriteData(0x14);
WriteData(0x2C);
WriteData(0x32);
WriteComm(0xe1);
WriteData(0xD0);
WriteData(0x05);
WriteData(0x0A);
WriteData(0x0A);
WriteData(0x07);
WriteData(0x28);
WriteData(0x32);
WriteData(0x2C);
WriteData(0x49);
WriteData(0x18);
WriteData(0x13);
WriteData(0x13);
WriteData(0x2C);
WriteData(0x33);

WriteComm(0x29);
Delays (120);
}
```

```

Void ST7789sPanelSleepInMode (void)
{
Write command 0x10;
Delaysms (120);
}
Void ST7789sPanelSleepOutMode (void)
{
Write command 0x11;
Delaysms (120);
}

```

10. LCD Test Pattern

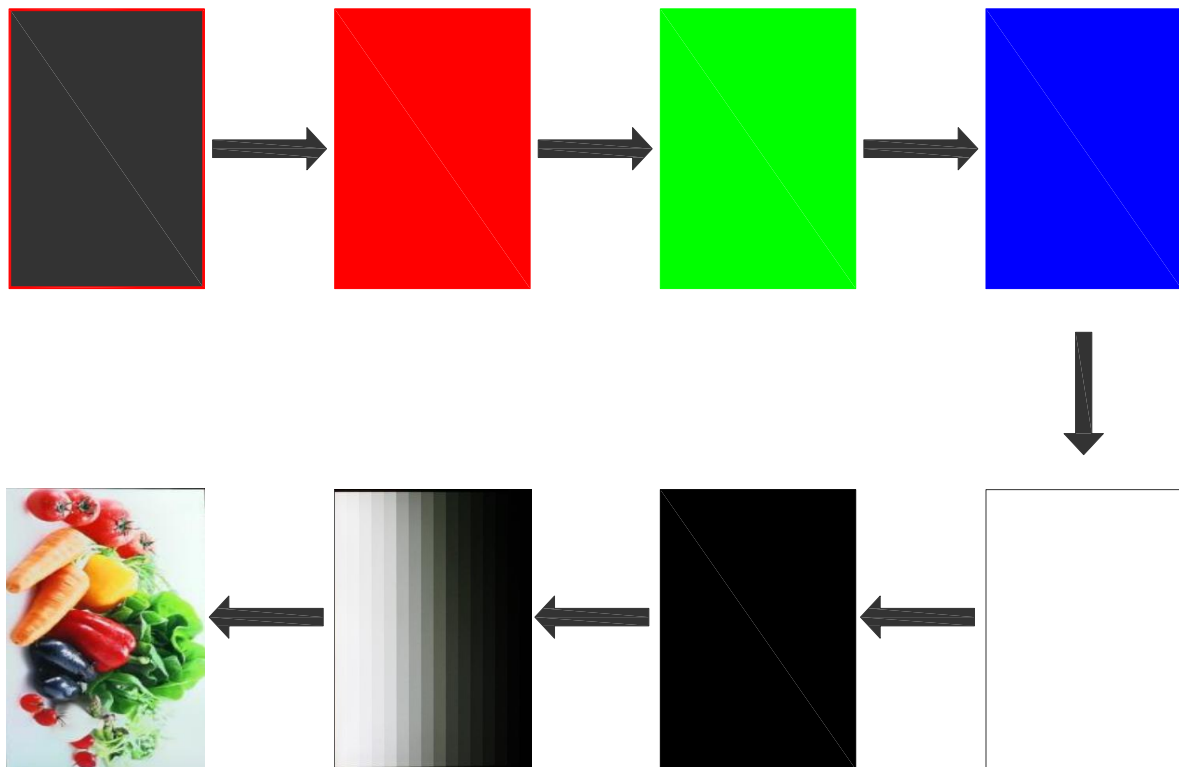

Pattern	Red frame	Red	Green	Blue	White	Black	Gray scale	Image
Current (mA)	3.45	3.97	4.05	3.97	5.33	3.44	3.80	4.40